

**STUDY WORK PLAN  
FOR  
ENGINEERED EARTHEN-BOTTOM FLOOD CONTROL CHANNELS  
LOCATED WITHIN THE  
LOS ANGELES RIVER WATERSHED**

**MAINTAINED AND OPERATED BY THE  
LOS ANGELES COUNTY FLOOD CONTROL DISTRICT**

**IN COMPLIANCE WITH THE  
WASTE DISCHARGE REQUIREMENTS  
FILE NUMBER 99-011-2010WDR**

**PREPARED FOR:**

**Section 401 Certification Unit  
California Regional Water Quality Control Board  
320 W. 4th Street, Suite 200  
Los Angeles, CA 90013**



**PREPARED BY:**

**Los Angeles County Flood Control District  
County of Los Angeles Department of Public Works  
900 S. Fremont Avenue, Alhambra, CA 91803**



**JULY 2010**

## Table of Contents

1. Introduction.....	1
2. Feasibility Study Requirements.....	1
3. Approach.....	3
4. Work Plans.....	4
4.1 Hydraulic Analysis.....	4
4.1.1. Location.....	4
4.1.2. Objective.....	4
4.1.3. Office and Field Investigations.....	5
4.1.4. Hydraulic Analysis Modeling.....	5
4.1.5. Hydraulic Analysis Report.....	7
4.2 Biological Technical Assessments.....	7
4.2.1. Literature Review.....	7
4.2.2. Field Surveys.....	8
4.2.3. Vegetation Transect Data Collection.....	8
4.2.4. Focused Surveys for Special Status Plant Species.....	9
4.2.5. Focused Surveys for Threatened and Endangered Wildlife Species.....	10
4.2.6. Biological Technical Assessment Report.....	10
4.2.7. Recommendations.....	11
4.3 Water Quality Monitoring and Best Management Practices Plan (BMP).....	11
4.3.1 Pre-Project Monitoring.....	13
4.3.2 Project Monitoring.....	13
4.3.3 Post-Project Monitoring.....	14
4.3.4 Best Management Plan.....	14
4.3.5 Water Quality Data Analysis Submittal.....	15
4.4 Stakeholders Solicitation.....	15
4.4.1 Objective.....	15
4.4.2 Stakeholder Identification.....	15
4.4.3 Soliciting Stakeholder Input.....	16
4.4.4 Technical Assessment Report and Recommendations.....	16
4.4.5 Information Access on LACFCD Internet Website.....	16
4.4.6 LACFCD Internet Website for Soft-Bottom Channel Maintenance.....	16

## List of Figures

Figure 1 Map of the Los Angeles County Soft-Bottom Reaches

Figure 2 Los Angeles River Watershed Map with Channel Reach Locations

## List of Tables

Table 1 List of Soft-Bottom Channels within the Los Angeles River Watershed

## **Attachments**

- Attachment 1 Waste Discharge Requirements for Los Angeles County Flood Control District, Proposed Maintenance Clearing of Engineered Earth-Bottom Flood Control Channels, Los Angeles County (Order No. R4-2010-0021)
- Attachment 2 Sample Copy of a Shot of a Stream Channel Transect
- Attachment 3 Sample of a Completed Comparison of Species Composition and Coverage Data Sheet
- Attachment 4 Sample Form used by Biologists during Transect Data Survey
- Attachment 5 Sample Water Quality Monitoring (WQ) Field Data Sheet
- Attachment 6 Sample of a Chain of Custody Form
- Attachment 7 Sample copy of a Completed WQ Sampling Monitoring Test and Lab Result
- Attachment 8 Best Management Practices (BMP) Manual for Soft-Bottom Channel Clearing

## 1. Introduction

The Los Angeles County Flood Control District (LACFCD) owns and maintains numerous engineered soft-bottom flood control channels within the County of Los Angeles (County). These channels convey storm flows from the open space and urban areas within their tributary watersheds. The LACFCD conducts annual maintenance on these facilities to protect life and property from potential flooding, fire hazards, control vector nuisance issues, so facilities may efficiently and effectively function as designed.

In order to maintain these facilities, LACFCD obtains environmental regulatory permits from the Los Angeles Regional Water Quality Control Board (Regional Board). The Regional Board has jurisdiction over water quality issues, under the Section 401 Water Quality Certification, on any activities performed at facilities located within the waters of the United States. Other regulatory agencies that have jurisdiction over these facilities include the California Department of Fish and Game (CDFG) and the U.S. Army Corps of Engineers (COE).

Maintenance activities within these facilities have been and continue to be performed according to valid regulatory permits with these agencies. Prior to expiration of these regulatory permits, LACFCD is responsible for obtaining new permits or permit renewals or extensions.

On February 4, 2010, the Regional Board adopted the Waste Discharge Requirements (WDR), Order No. R4-2010-0021, for the maintenance of the aforementioned soft-bottomed flood control channels (project). See Attachment 1 for a copy of the WDR. The adopted WDR includes additional conditions that were not part of Section 401 Water Quality Certification, previously issued for the project. As part of the WDR, a Feasibility Study is required to be conducted within six years for all the earth-bottomed channels in each watershed within the County. For the first year, a Feasibility Study is required for the Los Angeles River Watershed. This report addresses that requirement.

## 2. Feasibility Study Requirements

Conditions 44 through 51 of the WDR require that a Feasibility Study be conducted to determine whether the “channel clearing activities have avoided, minimized, or appropriately mitigated for effects on the beneficial uses of the affected reaches or to require changes to channel clearing activities to achieve the necessary avoidance, minimization or mitigation.”

For clarity and reference on the basis of this report, complete language of specific permit conditions of the WDR are provided throughout this report.

Condition 45, Feasibility Study and Stakeholders' Notification, states.

“As part of the on-going assessment of channel conditions and hydraulic capacity, LACFCD shall perform a study of the hydraulic capacity and existing conditions of all reaches covered by this WDR to determine where a potential may exist for native vegetation to remain within the soft-bottom portion of the channel or if additional hydraulic capacity is needed (Feasibility Study). In addition, any channels which may potentially provide restoration opportunities for riparian habitat/vegetation growth shall be identified based on these assessments and a consideration of restoration plans by other agencies. LACFCD shall implement the Feasibility Study process with a schedule of one or more watersheds per year to be analyzed, with completion of all watersheds/studies within six (6) years. LACFCD shall solicit stakeholder input during the Feasibility Study Work Plan development and prior to the finalization of the Technical Assessment Report and Recommendations.” Figure 1 is a map of the Los Angeles County showing locations of all soft-bottom channels by watershed.

Condition 46, Required Watershed for Year One Feasibility Study, states

“In the first year, the Feasibility Study shall be required for the Los Angeles River Watershed (which includes the mainstem reaches and all tributaries, including Compton Creek, covered by this WDR). See Figure 2 for locations of soft-bottom channels within the Los Angeles River Watershed. The study area shall include any channels directly or indirectly affected by proposed maintenance. Each year, LACFCD and the Regional Board Executive Officer shall determine in which watershed(s) the Feasibility Study shall be conducted in the subsequent year ”

Condition 47, Feasibility Study Components, states.

“For each watershed, the Feasibility Study shall include (but not be limited to) the following components:

- a. Study Workplan
- b. Technical Assessment Report
- c. Recommendations”

This report will comply with the Study Workplan requirement of the Feasibility Study

Condition 48, Study Workplans, states.

“Within 5 months of WDR issuance, a Workplan for the first watershed shall be submitted to the Regional Board Executive Officer for approval. The plan will include: a detailed plan for a hydraulic analysis of each earth-bottom segment in relation to the conveyance capacity of the upstream and downstream channels, in addition to the Water Quality Monitoring. The hydraulic analysis

shall include, but not limited to, the height and density of vegetation in the earthen channel bottom and its effect on the conveyance capacity of flood flow in the channel and shall include discussion of changes in expected stream flow in response to requirements of the Los Angeles County Municipal Separate Storm Sewer (MS4) NPDES Permit, Standard Urban Stormwater Mitigation Plans (SUSMPs), Total Maximum Daily loads (TMDLs) and other pertinent local plans including, but not limited to the Integrated/Regional Water Management Plan (IRWMP) (including implementation of, and plans for, increased stormwater infiltration), the City of Los Angeles' Integrated Resources Plan, the relevant watershed master plan and the LACFCD's Drought Management Plan. Several reasonable Manning's Numbers should be used in the hydraulic analysis to evaluate the representative height of the channel for flood control and natural habitat purposes and should be in accordance with "Guide for Selecting Manning's Roughness coefficients for Natural Channels and Flood Plains," United States Geological Survey Water-Supply Paper 2339 or other appropriate guidance.

The assessment of biological functions and values of these reaches should be made such that comparisons of habitat type, maturity and extent of native or invasive plants can be made between reaches."

### **3. Approach**

To comply with the first component of the Feasibility Study, a Study Workplan (Workplan) for engineered earth-bottom channels within the Los Angeles River Watershed is proposed for the first year. This Workplan will outline the methodology, steps, and procedures of how the hydraulic study, biological studies, water quality monitoring, and stakeholders' notification will be performed and coordinated.

In addition, the Workplan includes discussion and an outline on how the second and third components of the Feasibility Study (i.e., Technical Assessment Report and Recommendations) will be accomplished.

The following are the specific WDR permit conditions related to the last two components of the Feasibility Study:

Condition 50, Technical Assessment Report – Hydraulic and Water Quality Assessment, states:

"Within 7 months of Workplan approval, a Technical Assessment Report shall be submitted and will include a reach-by-reach list of all the reaches included in the subject watershed with a hydraulic analysis of each reach.

This report will also include an assessment of the biological functions and values for each reach and an assessment of water quality, as required. For each reach,

the report shall address capacity requirements for flood control; design criteria and anticipated limitations, and an analysis either of potential areas where vegetation may remain and areas with the potential for restoration of native vegetation or where justification exists to clear additional vegetated areas. For those areas where vegetation may remain, the technical assessment report should specify the amount(s) and type(s) of native vegetation that could remain in the channel.”

Condition 51, Recommendation, states.

“Within 7 months of Workplan approval, recommendations shall be submitted to the Regional Board Executive Officer and shall include options for reaches where vegetation may be allowed to remain or where native vegetation could be re-established. Recommendations shall also include suggested schedules of vegetation removal frequency in order to ensure the maximum habitat preservation, consistent with necessary flood control, is achieved. For recommendations approved by the Executive officer, LACFCD shall make the necessary changes to the Maintenance Plan, including proposals for additional BMP’s as may be appropriate, and shall submit such changes to the Executive officer 21 days prior to any clearing activities.”

## **4. Workplans**

As previously noted earlier, Condition 48 of the WDR requires the LACFCD to submit a Workplan for review and approval to the Regional Board’s Executive Officer. After its approval, LACFCD will submit the required Technical Assessment Report and the Recommendations.

The following sections outline the steps that are necessary to develop the technical report and recommendations that are needed to complete the Feasibility Study

### **4.1 *Hydraulic Analysis***

#### **4.1.1 Location**

The project is located in the Los Angeles River Watershed. There are 26 defined soft-bottom reaches in the Regional Board’s WDR within the Los Angeles River Watershed. These 26 channel reaches vary in length from 25 feet to as long as 11,000 feet (see Table 1 for a complete listing and details of all 26 channel reaches)

#### **4.1.2 Objective**

- a Prepare HEC-RAS hydraulic models using the COE Hydrologic Engineering Center River Analysis System computer program for the 26 soft-bottom channel reaches defined in the Regional

Board's Waste Discharge Requirement Permit for Los Angeles River Watershed. These hydraulic models will be used to determine whether or not the channel reaches currently have adequate flood control capacity

- b. For reaches identified as currently having adequate flood control capacity, the models will then be used to evaluate what amount of vegetation can be allowed to grow without compromising capacity. This will be done in conjunction with recommendations from the LACFCD's biological consultant.
- c. For reaches not having adequate flood control capacity, the models will then be used to evaluate the removal of vegetation necessary to restore capacity, in conjunction with recommendations from the biological consultant.

#### **4.1.3 Office and Field Investigations**

- a. As-built and other plans, including those for channels, structures, bridges, and utilities, along with topographic mapping, and field surveys within the study area, shall be collected and reviewed to determine existing channel configuration and conditions.
- b. For locations where as-built and other plan data are not available, LACFCD shall research, collect, organize, and review all readily available spatial data.
- c. Field investigations shall be conducted for all 26 soft-bottom reaches of the Los Angeles River Watershed to verify channel geometry, stability, and roughness values. The field investigations shall occur between mid-July and mid-August when channel reaches are expected to contain the maximum amount of vegetation re-growth, prior to annual vegetation removal during fall maintenance activities. The existing vegetation shall be observed taking note of type, density, and size. All the reaches shall be photographed for documentation purposes.
- d. LACFCD shall research, collect, organize, and review all readily available hydrologic studies as well as other documentation pertaining to the 26 soft-bottom reaches of the Los Angeles River Watershed.

#### **4.1.4 Hydraulic Analysis Modeling**

- a. LACFCD shall prepare one-dimensional steady-flow hydraulic models for all the project reaches using HEC-RAS.



- b. The cross section locations and intervals will be coordinated to ensure consistency and to make certain the channel and project areas are completely and adequately represented in the models.
- c. Hydraulic roughness coefficients for all project reaches shall be determined using field notes, aerial photographs, and several hydraulic references. The hydraulic roughness coefficients shall be representative of current observed field conditions and correlated with biological consultant's vegetation transect survey.
- d. Some of the hydraulic references that shall be used to determine the hydraulic roughness coefficients include "*Open-Channel Hydraulics*" by Ven T Chow and "*Guide for Selecting Manning's Roughness Coefficients for Natural Channels and Flood Plains*," United States Geological Survey Water-supply Paper 2339
- e. The general modeling guidelines for bridges shall be followed closely. For vertical piers, 2 feet of debris accumulation on each side of each pier shall be used and loss coefficients and other data shall be adjusted accordingly. For piers with sloping extensions, 2 feet of debris accumulation for a distance up to 6 feet below the water surface shall be assumed.
- f. LACFCD shall perform the steady flow computations using HEC-RAS for the design flow rates for each project reach.
- g. The limits for data collection upstream and downstream of the study reach shall be at a distance such that any user-defined boundary condition will not affect the results within the study reach.
- h. LACFCD shall run the hydraulic analyses under a mixed flow regime. Manning's equation shall be used to compute normal depth as the starting water surface boundary condition. A sensitivity analysis shall be performed by selecting other starting water surface boundary conditions to ensure that the limits for data collection upstream and downstream of the study reach are sufficient.
- i. LACFCD shall include discussion of changes in expected stream flow in response to requirements of the Los Angeles County Municipal Separate Storm Sewer (MS4) NPDES Permit, Standard Urban Stormwater Mitigation Plans (SUSMPs), Total Maximum Daily Loads (TMDLs) and other pertinent local plans including, but not limited to the Integrated Regional Water Management Plan (IRWMP) (including implementation of, and plans for, increased stormwater infiltration), the City of Los Angeles' Integrated

Resources Plan, the relevant Watershed Master Plan, and the LACFCD's Drought Management Plan.

- j. LACFCD shall perform separate hydraulic analyses of the project reaches having adequate flood control capacity using several reasonable hydraulic roughness coefficients in potential areas where vegetation may remain and areas with the potential for restoration of native vegetation. Identification and location of these potential areas shall be discussed. Vegetation type, density, and height are factors necessary to determine appropriate hydraulic roughness coefficients.
- k. Conversely, LACFCD shall perform separate hydraulic analyses of the project reaches not having adequate flood control capacity using several reasonable hydraulic roughness coefficients in potential areas where vegetation may need to be removed. Identification and location of these potential areas shall be discussed with a biological consultant. Vegetation type, density, and height are factors necessary to determine appropriate hydraulic roughness coefficients.

#### **4.1.5 Hydraulic Analysis Report**

LACFCD shall prepare a Hydraulic Analysis Report that documents and summarizes all of the data collected and processed. The Hydraulic Analysis Report shall include a written narrative that describes the hydraulic characteristics of the project study areas. The report shall also contain sufficient detail in terms of tables, equations, graphic displays, and example computations to allow an independent assessment of the soundness of the report results and conclusions.

## **4.2 Biological Technical Assessment**

The biological studies described in this Workplan will be conducted at each of the 26 channel reaches.

### **4.2.1 Literature Review**

A literature review will be conducted to review and update existing information gathered through the soft-bottom channel maintenance program about species that have been afforded special status by State, Federal, and local resource agencies and organizations and have a potential to occur within the Los Angeles River Watershed.

Sources to be reviewed include:

- a. Special status species lists from CDFG, U.S. Fish and Wildlife Service (USFWS), and California Native Plant Society (CNPS);
- b. Database searches of the California Natural Diversity Database (CNDDDB) and the Electronic Inventory of the CNPS,
- c. Most recent Federal Register listing package and critical habitat determination for each federally listed endangered or threatened species potentially occurring within the project sites,
- d. CDFG Annual Report on the status of California's listed threatened and endangered plants and wildlife, and
- e. Other biological studies conducted in the Los Angeles River Watershed that may be relevant to this feasibility study

#### **4.2.2 Field Surveys**

Field surveys will be conducted by a qualified botanist and wildlife biologist to identify the plant and wildlife species present at each channel reach maintained by LACFCD in the Los Angeles River Watershed. The vegetation types and wildlife habitats will be described, mapped, and quantified.

The surveys are expected to be conducted during the summer season when the majority of plant species present at the channel reaches will be identifiable. Because most migratory birds will have moved through the region, only the breeding birds should be present during the survey. A vegetation map will be produced and included with the final report. Photographs of existing conditions will also be obtained.

These surveys will be conducted prior to initiation of the annual LACFCD fall season maintenance activities.

#### **4.2.3 Vegetation Transect Data Collection**

Two sets of vegetation transect data will be collected for each of the 26 channel reaches maintained by the LACFCD in the Los Angeles River Watershed. Transect data will provide percent cover of vegetation relative to unvegetated areas of the channel reaches for comparison between and within the channel reaches. The transect data will also include comparison of native and non-native vegetation types, and will generate relative abundance data for individual plant species. See Attachments 2 and 3 for sample copies of a shot of a Stream Channel transect and a completed comparison of Species

Composition and Coverage data sheet. Attachment 4 is a sample form used by biologists during the Transect Data collection survey

The first set of transects will be performed during the summer season prior to initiation of the annual fall maintenance activities conducted by the LACFCD

The second transect set will be conducted as soon as possible after completion of fall maintenance activities. Transect number and location will be correlated with the hydraulic roughness coefficients values developed by the LACFCD's hydraulic analysis. This information will provide a biological basis for these values.

Performance of the first set of transects is scheduled to be completed in August, following LACFCD's field surveys that are expected to occur between mid-July and mid-August.

Note that these surveys and transects are scheduled to occur during the time period when the channel reaches are expected to contain the maximum amount of vegetation re-growth prior to its removal during fall maintenance activities.

The total number of reach "segments" identified with individual hydraulic roughness coefficients will determine the total number of vegetation transects to be conducted for this task. Each transect will be conducted to measure vegetation cover and species diversity using the line-intercept method

Global Positioning System data points will be collected for each of the transect locations. Transects will be conducted perpendicular to the stream ("bank to bank") and will be of varying width. Transect locations will include "maintained areas" of the channel reach in order to provide comparison between pre-clearing maintenance activities and post-clearing activities.

#### **4.2.4 Focused Surveys for Special Status Plant Species**

Focused Surveys for Special Status Plant Species will be conducted for each of the 26 channel reaches in the Los Angeles River Watershed. These surveys will be conducted during the blooming periods for each of the plants, which vary depending on rainfall and temperature. Therefore, reference populations will be monitored to determine the appropriate survey time (generally between March and July). See attachment for a sample copy of the data collection forms.

Since blooming periods for special status plant species typically overlap, surveys of the 26 channel reaches in early spring and again in late spring can be conducted to cover most of the desired species.

A total of nine surveys are required to cover all 26 channel reaches. There are a few species that bloom in late summer or fall, however, and may not be detected during spring surveys.

Since only a few of the 26 channel reaches in the Los Angeles River Watershed are expected to support suitable habitat for these late summer or fall special status plant species, two surveys will be conducted at less than ten channel reaches during this time period (August through October)

The focused surveys will be conducted using meandering transects throughout potential habitat of each channel reach. Field notes will be taken during the surveys. If any special status plant species are found, the location of each population will be mapped and voucher specimens will be collected and deposited in an appropriate herbarium to ensure the accuracy of the identification.

Any special status species observed will be reported to the California Natural Diversity Data Base (CNDDDB)

#### **4.2.5 Focused Surveys for Threatened and Endangered Wildlife Species**

Focused surveys for threatened and endangered wildlife species are conducted bi-annually for the soft-bottom channel maintenance program. These surveys were initiated in 2002 and 2003 at channel reaches selected by the U.S. Fish and Wildlife Service for their potential to support threatened and endangered wildlife species.

Of the 26 channel reaches included in the feasibility study for the Los Angeles River Watershed, focused surveys were conducted in 2009 at channel reaches #12 (Haines Canyon Main Channel Outlet) and #14 (May Channel Outlet). These and previous focused survey results for these 26 channel reaches will be included in the biological technical assessment.

#### **4.2.6 Biological Technical Assessment Report**

After collection of all post-clearing vegetation transects data, a biological technical assessment report will be prepared that documents plant and wildlife species observed at each of the 26 channel reaches in the Los Angeles Watershed

The Biological Technical Report will include.

- a. Methodology used to conduct the biological surveys and vegetation transects,

- b. Description of the existing vegetation types and associated wildlife resources, including maps of existing vegetation types for each of the 26 channel reaches;
- c. Results of focused surveys for special status plant and wildlife species in the channel reaches,
- d. Comparison of biological functions and values between each of the 26 channel reaches,
- e. Comparison of vegetation transects with WDR's hydraulic roughness coefficients;
- f. Value rankings based on biological function and value for each of the 26 channel reaches, and
- g. Amount(s) and type(s) of native vegetation that could remain in each channel reach.

#### **4.2.7 Recommendations**

The value rankings developed for each of the 26 channel reaches in the biological technical assessment will be correlated with the hydraulic analysis to develop recommendations regarding where and what vegetation should be removed and/or can be allowed to remain. The value rankings will also include suggested schedules of vegetation removal frequency in order to ensure maximum habitat preservation is achieved, consistent with the necessary level of flood control.

If the hydraulic analysis determines that any of the 26 channel reaches can support more substantial vegetation, then value rankings in the biological technical assessment can be used to identify appropriate areas for re-establishment of additional native vegetation.

### **4.3 *Water Quality Monitoring and Best Management Practices (BMP) Plan***

The Feasibility Study requires Water Quality (WQ) Monitoring and BMP activities to be analyzed.

Condition 43, Best Management Practices, states:

“All appropriate Best Management Practices (BMPs) shall be implemented in order to avoid impacts to water quality that would result in exceedances of water quality standards. The Project shall not result in indirect impacts to

water quality or beneficial uses of downstream water bodies. The Project shall not result in changes in the quality of storm water downstream water bodies during maintenance or during operation subsequent to the maintenance activities. The Project shall not result in changes in the quality of storm water discharge during periods between maintenance activities, or upon its completion.”

Condition 49, Water Quality Monitoring, states.

“The objectives of the water quality monitoring are to assess BMP effectiveness and to ensure that water quality is not impacted as a result of the proposed maintenance activities, or surface water diversion. BMPs are to be implemented in association with maintenance activities to avoid impacts to water quality which would result in exceedances of water quality standards

As part of the Feasibility Study, water quality assessments within each reach will be required on a one-time basis before, during, and after maintenance clearing activities. Each project reach will require three (3) sampling stations. upstream of the project; within the project; and downstream of the project.

The testing parameters required will be the same as for Surface Water Diversion

- pH
- temperature
- dissolved oxygen
- turbidity
- total suspended solids (TSS)

Downstream TSS shall be maintained at ambient levels. Where natural turbidity is between 0 and 50 Nephelometric Turbidity Units (NTU), downstream increases shall not exceed 20%. Where natural turbidity is greater than 50 NTU, downstream increases shall not exceed 10%.

Analyses must be performed using approved U S. Environmental Protection Agency methods, where applicable.

These constituents shall be measured at least once prior to the maintenance activity and then monitored on a daily basis during the first week of maintenance activities, and then on a weekly basis, thereafter, until the work is complete. When reaches are within the watershed designated for a Feasibility Study in a particular year, water quality monitoring should be conducted for those reaches as part of the Feasibility Study and reported with the Technical Assessment Report.

Any exceedances of water quality standards may result in corrective and/or enforcement actions, including increased monitoring and sample collection.”

The LACFCD will address the planning and implementation of the WQ monitoring aspect of the Feasibility Study as well as handle and address issues relating to BMPs.

The following is a step-by-step process by which LACFCD will implement the WQ monitoring Attachment 5 is a copy of a Field Data sheet to be used for recording WQ measurements and taking water samples. Attachment 6 is the Chain of Custody form that will be used to submit water samples to the Contract Environmental Lab. Attachment 7 is a sample copy of a completed WQ Sampling Monitoring Test and Lab result performed at Kagel Canyon Channel, one of the reaches within the Los Angeles River watershed.

#### **4.3.1 Pre-Project Monitoring**

- a. Pre-Project Monitoring to establish natural channel conditions
  - a) Field Reconnaissance/Cleanout operations/approach/methods
  - b) Scope of project; Location and type of BMPs
  - c) Estimated duration
  - d) WQ monitoring parameters
- b. Define upstream (U), within project (W) and downstream (D) sampling points
- c. Initiate measurements and record WQ data at U/W/D sampling points
  - a) Field measurements
    - PH
    - Temperature (T)
    - Turbidity
  - b) Lab samples
    - Dissolved O<sub>2</sub>, Standard Method (SM) 4500-OG
    - Total Suspended Solids, SM 2540/EPA 160.2
    - Deliver samples to lab
  - c) Lab results
    - Normal turn-around-time = 5 days

#### **4.3.2 Project Monitoring**

- a. For the first week, water sampling will be taken once a day



- b. For subsequent weeks, water sampling will be taken once a week
- c. Check in with Crew Leader, Foreman, etc.
  - a) Discuss changes in scope/duration
  - b) Discuss WQ measurements
- d. WQ monitoring/sampling at U/W/D sampling points
  - a) Field measurements
  - b) Lab samples
  - c) Outside influences on WQ
- e. E-mail notification to the Project Coordinator and/or Field Office Supervisor if the turbidity measurements exceed WDR limits

#### **4.3.3 Post Project Monitoring**

- a. Finalize field data sheets
- b. Prepare figures of U/W/D sampling points
- c. Receive lab reports
- d. Final data to include field data sheets, figures, and lab reports
- e. Submit final data within 30 days from the final sampling date for submittal to the Regional Board.

#### **4.3.4 Best Management Practices Plan**

The BMP Plan will determine which BMPs to implement within each reach to avoid indirect impacts to WQ or beneficial uses during maintenance or operation, or that would result in exceedances of WQ standards. The BMP Plan shall include the following:

- a. Continued implementation of approved BMPs appropriately selected for each channel reach based on the field condition, the type of maintenance work, and the type of equipment (mechanical or hand tools) necessary in completing the maintenance activity

The BMPs, listed in the current Soft-Bottom Channel's Monitoring Form prepared for each individual channel reach, were based on the LACFCD's "Best Management Practices Manual for Soft-Bottom Channels." The BMP Manual (see attachment 8) was previously prepared for and was approved by the Regional Board as part of the expired 401 Certification.

- b. If WQ test results for a particular reach indicate that BMPs being implemented are not working or may need additional BMPs, the LACFCD will modify existing BMPs with alternative and/or additional BMPs.

- c. LACFCD engineers, field, and WQ staff have been working together to research and test available BMPs from outside consultants and companies. Some alternative BMPs were actually used in past maintenance activities and were documented in the Monitoring Forms. LACFCD will continue to use and implement alternative BMPs that were found to be effective and efficient, as necessary

#### **4.3.5 Water Quality Data Analysis Submittal**

Provide a complete summary of WQ testing results, in tabular format, for each reach. Tables will provide data collected from before, during and after the cleanout for the three (3) sampling stations located upstream of the project, within the project, and downstream of the project. Comments will also be provided including, but not necessarily limited to, observed site conditions, BMPs installed on site, recommended modifications to BMPs, communications with field staff, and explanations for changes to previous conditions and measurements.

### **4.4 Stakeholder Solicitation**

The WDR requires the LACFCD to solicit stakeholder input and to make information on maintenance activities for soft-bottom channel reaches readily available to the public. The list of stakeholders will include affected and interested parties, municipalities, environmental groups, and organizations.

#### **4.4.1 Objective**

Solicit stakeholder input, during the development of the Workplan and prior to the finalization of the Technical Assessment Report and Recommendations. In addition, prior to any maintenance activities within the affected reaches of the Los Angeles River Watershed, watershed maps that specify areas of maintenance and approximate schedule shall be published on the LACFCD internet website. Stakeholders and other affected/interested parties shall be notified of these activities. After submission to the Regional Board Executive Officer, LACFCD shall post the Annual Project and Mitigation Monitoring Reports on the LACFCD internet website.

#### **4.4.2 Stakeholder Identification**

LACFCD shall identify watershed stakeholders in conjunction with the Regional Board to solicit comments from the parties interested in the WDR.

#### **4.4.3 Soliciting Stakeholder Input**

LACFCD shall notify the stakeholders via e-mail of the significance of the WDR and availability of the Workplan for review. This notification will state the deadline for receipt of comments and will also mention the Technical Assessment Report and Recommendations that will be available for their review and comment in the near future.

Upon receiving the comments, the LACFCD shall organize and incorporate the comments into the Work Plan, as appropriate.

#### **4.4.4 Technical Assessment Report and Recommendations**

Upon finalizing the Technical Assessment Report and Recommendations, LACFCD shall notify the stakeholders of the availability of the report and recommendations for their review and comment. LACFCD shall organize and incorporate the comments, as appropriate, into the final Technical Assessment Report and Recommendations.

#### **4.4.5 Information Access on LACFCD Internet Website**

Prior to any maintenance activities within the affected reaches of the Los Angeles River Watershed, watershed maps shall be published on the LACFCD internet website. Stakeholders and other affected/interested parties shall be notified of the scheduled maintenance activities. The information posted for scheduled maintenance activities shall include, but not be limited to, the proposed schedule; description of the channel reach existing conditions, area of proposed impact; and description of any existing aquatic resources. The Annual Project and Mitigation Monitoring Reports shall also be posted on the LACFCD internet website.

#### **4.4.6 LACFCD Internet Website for Soft-Bottom Channel Maintenance**

The LACFCD internet website will house the watershed maps, scheduled maintenance activities, Annual Project Report, and Mitigation Monitoring Report. LACFCD shall also notify the stakeholders of this website for their reference and use. LACFCD update the watershed maps and the Annual Project and Mitigation Monitoring Reports approximately once a year and the scheduled maintenance activities approximately once a week, during appropriate times of the year.

p:\fldpub\hq\jqc\master\_wdr (sbc) draft fs work plan (final).doc\_format.doc

**Figure 1**

**Map of the Los Angeles County  
Soft-Bottom Channel Reaches by Watershed**



# LOS ANGELES COUNTY Soft Bottom Reaches

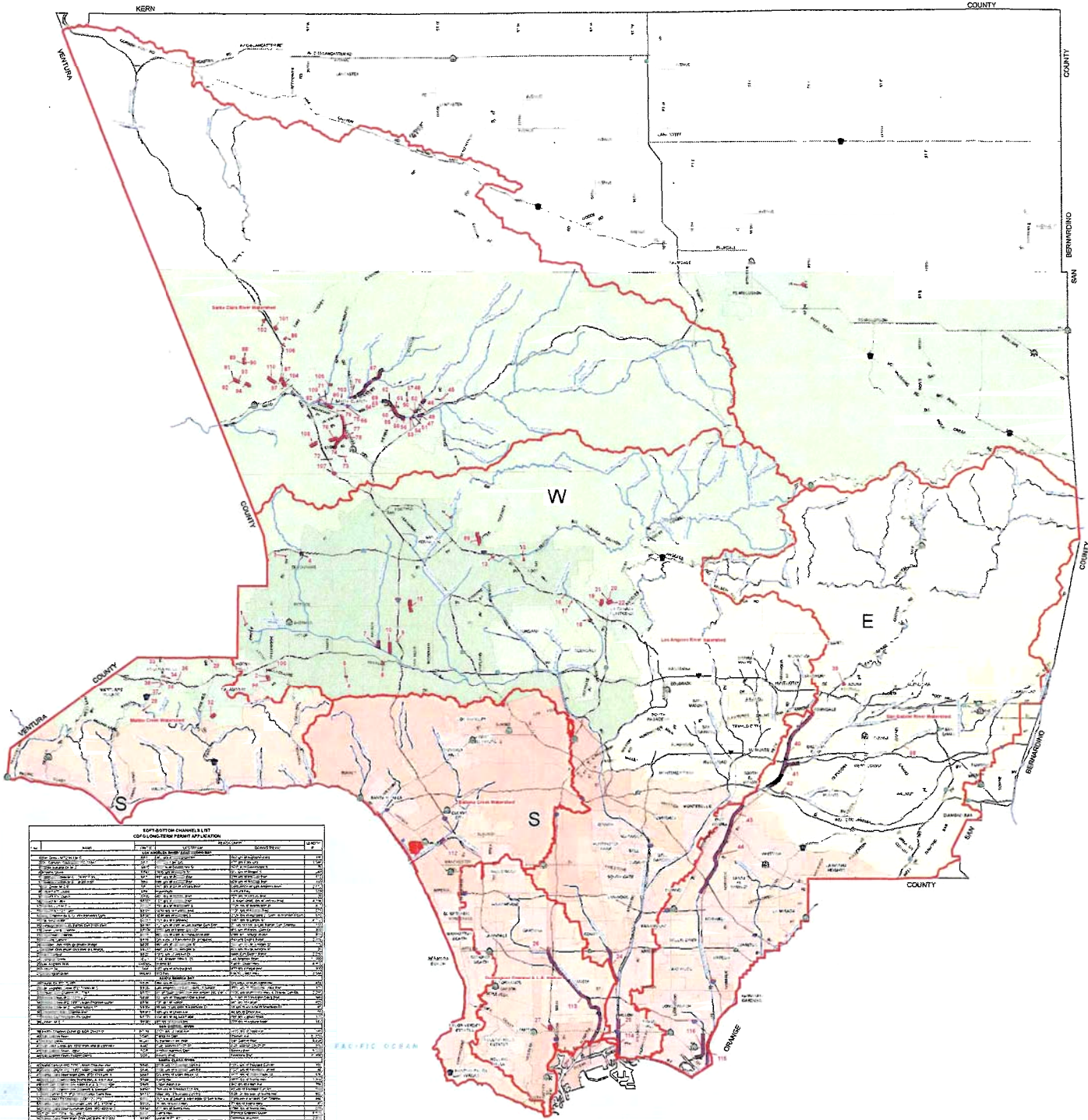

**SOFT BOTTOM CHANNELS & LIST OF FLOODING PERMIT APPLICATIONS**

NO.	NAME	ADDRESS	PERMIT NO.	DATE	STATUS	REMARKS
1	...	...	...	...	...	...
2	...	...	...	...	...	...
3	...	...	...	...	...	...
4	...	...	...	...	...	...
5	...	...	...	...	...	...
6	...	...	...	...	...	...
7	...	...	...	...	...	...
8	...	...	...	...	...	...
9	...	...	...	...	...	...
10	...	...	...	...	...	...
11	...	...	...	...	...	...
12	...	...	...	...	...	...
13	...	...	...	...	...	...
14	...	...	...	...	...	...
15	...	...	...	...	...	...
16	...	...	...	...	...	...
17	...	...	...	...	...	...
18	...	...	...	...	...	...
19	...	...	...	...	...	...
20	...	...	...	...	...	...
21	...	...	...	...	...	...
22	...	...	...	...	...	...
23	...	...	...	...	...	...
24	...	...	...	...	...	...
25	...	...	...	...	...	...
26	...	...	...	...	...	...
27	...	...	...	...	...	...
28	...	...	...	...	...	...
29	...	...	...	...	...	...
30	...	...	...	...	...	...
31	...	...	...	...	...	...
32	...	...	...	...	...	...
33	...	...	...	...	...	...
34	...	...	...	...	...	...
35	...	...	...	...	...	...
36	...	...	...	...	...	...
37	...	...	...	...	...	...
38	...	...	...	...	...	...
39	...	...	...	...	...	...
40	...	...	...	...	...	...
41	...	...	...	...	...	...
42	...	...	...	...	...	...
43	...	...	...	...	...	...
44	...	...	...	...	...	...
45	...	...	...	...	...	...
46	...	...	...	...	...	...
47	...	...	...	...	...	...
48	...	...	...	...	...	...
49	...	...	...	...	...	...
50	...	...	...	...	...	...

N

MPM-CIS Services

**Legend**

- Watershed Management Boundary
- Major Channel
- Soft Bottom Reaches
- Flood Maintenance Yards**
- East
- South
- West

**Figure 2**  
**Los Angeles River Watershed Map**  
**Soft-Bottom Channels**



**Table 1**  
**List of Soft-Bottom Channels within**  
**Los Angeles River Watershed**



**SOFT-BOTTOM CHANNELS LIST  
WITHIN THE LOS ANGELES RIVER WATERSHED  
LOS ANGELES FLOOD CONTROL DISTRICT (UPDATED 5/10)**

Reach No.	NAME	LIMITS		UPSTREAM		DOWNSTREAM		COWARDIN CLASS	CLASS OF AQUATIC RESOURCE	LENGTH (ft)	ACREAGE	MAJOR WATERSHED	USGS QUAD	THOMAS GUIDE
		UPSTREAM	DOWNSTREAM	Latitude	Longitude	Latitude	Longitude							
<b>LOS ANGELES RIVER WATERSHED</b>														
1	Bell Creek- MTD 963 M.C.I.	962' u/s of Highlander Rd	766' u/s of Highlander Rd	34.20286	118.65745	34.20182	118.65679	Riverine	Section 404	196	0.90	Los Angeles River	Calabasas	529-D5
2	Dry Canyon (Calabasas) PD T1845	676' u/s Park Ora	870' d/s Park Ora	34.14733	118.62940	34.15077	118.63113	Riverine	Section 404	1,546	1.24	Calabasas	Calabasas	559-G5
3	Santa Susana Ck M.C.I.	5560' N of Devonshire St	5635' N of Devonshire St	34.27081	118.60868	34.27097	118.60892	Riverine	Section 404	75	0.06	Los Angeles River	Oat Mountain	499-J2
4	Browns Creek	1895' u/s of Rinaldi St	556' u/s of Rinaldi St	34.27148	118.58990	34.27495	118.59082	Riverine	Section 404	1,243	3.00	Los Angeles River	Oat Mountain	500-B2
5	Caballero Creek M.C.I. (West Fork)	890' u/s of Reseda Blvd	238' u/s of Reseda Blvd	34.15058	118.53587	34.14914	118.53621	Riverine	Section 404	652	1.30	Los Angeles River	Canoga Park	560-J5
6	Caballero Creek M.C.I. (East Fork)	588' u/s of Reseda Blvd	428' u/s of Reseda Blvd	34.15010	118.53571	34.14987	118.53555	Riverine	Section 404	160	0.35	Los Angeles River	Canoga Park	560-J5
7	Bull Creek M.C.O.	165' d/s of cl of Victory Blvd	Confluence w/ Los Angeles River	34.17890	118.49657	34.18616	118.49673	Riverine	Section 404	2,602	5.61	Los Angeles River	Van Nuys	531-D7
8	Project 470 Outlet	Havenhurst	Ventura Fwy	34.16349	118.49125	34.16468	118.49001	Riverine	Section 404	529	0.30	Los Angeles River	Van Nuys	561-E3
9	Project 108 Outlet	400' d/s of Victory Blvd	520' d/s of Victory Blvd	34.18523	118.47415	34.18555	118.47416	Riverine	Section 404	120	0.12	Los Angeles River	Van Nuys	531-G7
10	Project No 469	751' d/s of Victory Blvd	LA River (4945' d/s of Victory Blvd)	34.18475	118.48297	34.17356	118.48279	Riverine	Section 404	4,194	7.12	Los Angeles River	Van Nuys	531-J7 to 561-F1
<b>LOS ANGELES RIVER WATERSHED</b>														
12	Haines Cyn M.C.O.	791' d/s of Wentworth St	1228' d/s of Wentworth St	34.26849	118.31963	34.26869	118.32157	Riverine	Section 404	437	0.40	Tujunga Wash	Sunland	503-F2
13	Project No 5215 unit 1	1030' d/s of Foothill Blvd	1535' d/s of Foothill Blvd	34.27143	118.35834	34.26999	118.35881	Riverine	Section 404	537	0.55	Tujunga Wash	Sunland	503-B2
14	May Channel (M.C.O. into Pacoima Cyn)	3038' d/s of Hubbard St	3728' d/s of Hubbard St/Conf. W/Pacoima Cyn	34.31241	118.41008	34.31051	118.40888	Riverine	Section 404	690	0.63	Pacoima Wash	San Fernando	482-E3
15	Pacoima Wash	159' d/s of Parthenia	1187' d/s of Lanark St	34.21470	118.45716	34.22779	118.45844	Riverine	Section 404	4,762	5.25	Tujunga Wash	Van Nuys	531-H1 to J3
16	Verdugo Wash-Las Barras Cyn (chnl inlet)	157' u/s of conf. w/Las Barras Cyn Chnl	27' u/s of conf. w/Las Barras Cyn Channel	34.23336	118.26987	34.23335	118.27033	Riverine	Section 404	130	0.07	Verdugo Wash	Burbank	504-C7
17	Sheep Corral Channel	1150' u/s of Forest Glen Dr.	850' u/s of Forest Glen Dr.	34.22598	118.26317	34.22606	118.26222	Riverine	Section 404	300	0.14	Verdugo Wash	Burbank	534-D1
18	Engleheard Channel	800' u/s of conf w/ Verdugo Wash	Conf. w/ Verdugo Wash	34.20711	118.23999	34.20765	118.24236	Riverine	Section 404	800	1.10	Verdugo Wash	Pasadena	534-F3 to G3
19	Pickens Canyon	D/s edge of Panorama Dr	Pickens Debris Basin	34.22121	118.22870	34.22805	118.22709	Riverine	Section 404	2,406	3.42	Verdugo Wash	Pasadena	504-H5 to 534-H1
20	Webber Chnl (strm @ private bridge)	861' u/s of Los Amigos St	746' u/s of Los Amigos St	34.22815	118.21661	34.22795	118.21702	Riverine	Section 404	115	0.13	Verdugo Wash	Pasadena	504-J7
21	Webber Chnl (main chnl inlet d/s bridge)	496' u/s of Los Amigos St	471' u/s of Los Amigos St	34.22661	118.21876	34.22746	118.21782	Riverine	Section 404	25	0.03	Verdugo Wash	Pasadena	504-J7
22	Halls Canyon	1370' u/s of Jessen Dr	Halls Cyn Debris Basin	34.22317	118.22008	34.22678	118.21365	Riverine	Section 404	2,290	2.63	Verdugo Wash	Pasadena	534-J1
24	Compton Creek	COE Station 199+31.00	Los Angeles River	33.87611	118.21915	33.84242	118.20339	Riverine	Section 404	11,000	91.0	Los Angeles River	Long Beach	735-A7 to 765-C5
25	Los Angeles River	Willow St	Pacific Coast Hwy	33.80396	118.20365	33.79058	118.20354	Riverine	Section 404	4,800	56.20	Los Angeles River	Long Beach	795-C3 to C5
96	PD 1591	85' u/s of culvert under Vicasa	360' d/s of culvert under Vicasa Drive	34.14539	118.62917	34.14665	118.62916	Riverine	Section 404	320	0.92	Calabasas Creek	Calabasas	559-G5
99	Kagel Canyon	Blue Sage Drive	City of Los Angeles Boundary	34.29626	118.37683	34.28406	118.37360	Riverine	Section 404	4,858	1.67	Tujunga Wash	San Fernando	482-J5 to J7
100	Dry Canyon Calabasas	1835' u/s of Ave San Luis	1775' u/s of Ave San Luis	34.15558	118.63185	34.15548	118.63171	Riverine	Section 404	60	0.05	Calabasas Creek	Calabasas	559-G4

**Attachment 1**

**Waste Discharge Requirement Permit  
Order Number R4-2010-0021  
Los Angeles County Flood Control District  
Soft-Bottom Channel Maintenance Clearing**

**CALIFORNIA REGIONAL WATER QUALITY CONTROL BOARD  
LOS ANGELES REGION**

**ORDER No. R4-2010-0021**

**WASTE DISCHARGE REQUIREMENTS (WDR) FOR:**

**LOS ANGELES COUNTY FLOOD CONTROL DISTRICT (DISCHARGER),  
PROPOSED MAINTENANCE CLEARING OF ENGINEERED EARTH-BOTTOM  
FLOOD CONTROL CHANNELS, LOS ANGELES COUNTY (File No. 99-011, CI 9580)**

The California Regional Water Quality Control Board, Los Angeles Region, hereinafter Regional Board, finds that:

1. The Los Angeles County Flood Control District (LACFCD) is responsible for providing flood control through a network of channels (which are also waters of the State) throughout Los Angeles County to ensure public safety. Adequate channel capacity needs to be maintained in order to avoid any loss of life or property due to floods.
2. Channel capacity is maintained by clearing sediment, vegetation and debris within the channel to an engineered, pre-designed level.
3. For dredge and fill activities such as channel clearing, the Clean Water Act (CWA) requires permitting from the Army Corps of Engineers (ACOE) under CWA Section 404 and Water Quality Certification by the State under CWA Section 401. In addition, under the State of California Fish and Game Code, Section 1600, such activities are also regulated by a Streambed Alteration Agreement (SAA) issued by the California Department of Fish and Game (CDFG)
4. Such discharges may also be regulated under the State of California's Porter-Cologne Water Quality Control Act by Waste Discharge Requirements (WDR). Pursuant to California Water Code (CWC) section 13263, the Regional Water Quality Control Boards are required to prescribe waste discharge requirements (WDRs) for any proposed or existing discharge unless WDRs are waived pursuant to CWC section 13269.

**Background/History**

5. In 1997, LACFCD proposed complete clearing of 100 earth-bottom channels in anticipation of the El Niño storm season, representing a total of 886 acres. Of this acreage, approximately 203 acres were vegetated.
6. In 1999, a Streambed Alteration Agreement, Memorandum of Understanding was entered into by LACFCD and CDFG (MOU 5-076-99). During the time of the MOU development, the Regional Board and the ACOE developed the first programmatic permit and Certification for the earth-bottom channel maintenance activities utilizing limits developed for the 1997, pre El Niño, clearing. At that time, of the approximately 203 vegetated acres, identified by LACFCD as flood control channels only 48.2 acres were

- authorized for clearance activities. However, the Regional Board recognizes the need to develop a more comprehensive plan beyond direct use of the 1997 limits and the need to develop a plan that would allow for vegetation/habitat to remain, to the maximum extent feasible, within these earth-bottom channels.
7. The 48.2 acres impacted by removal of vegetation was mitigated by the establishment of the Big Tujunga Wash Mitigation Bank, which contains 62.7 acres, a 1.3:1 mitigation ratio.
  8. LACFCD's vegetation and debris clearing (maintenance) activities were permitted by the ACOE under CWA Section 404 Nationwide Permit 31 "Maintenance of Existing Flood Control Facilities" in 1998 which was certified by the Regional Board under CWA Section 401 Water Quality Certification (File No. 99-011) in 1999.
  9. The ACOE has authorized this work under Nationwide Permit 31 "Maintenance of Existing Flood Control Facilities." The ACOE (after evaluation of updated information), has reissued the Nationwide Permit every two years since 1998. The latest Nationwide Permit was issued in September 2008.
  10. The number of soft bottom channels authorized to be maintained under the Nationwide Permit has changed during each permit cycle due to channels being combined together, or the addition of new channels. The ACOE divides channels into reaches that it considers to be sensitive and non-sensitive based on a Biological Opinion from the US Fish and Wildlife Service. The ACOE normally incorporates special conditions such as avoidance of nesting seasons or hand clearing, for reaches it deems to be sensitive.
  11. The Water Quality Certification was renewed by the Regional Board on October 17, 2003, authorizing maintenance of 99 earth-bottom channels. At that time, the ACOE permitted maintenance of the same channels in a letter dated October 21 (61 channels), 2003 and in a letter dated December 22, 2003 (17 channels) under Nationwide Permit 31. ACOE total channel numbers differ from the CDFG or Regional Board Certification total channel numbers because the ACOE combined channels in their permits.
  12. In 2003, the State Water Resources Control Board issued State Water Resources Control Board Order No. 2003 - 0017 - DWQ, "General Waste Discharge Requirements for Dredge and Fill Discharges that have received State Water Quality Certification", which requires compliance with all conditions of Water Quality Certifications. The 2003 renewal of the Water Quality Certification also regulated the discharges from earth-bottom channel maintenance under that order.
  13. The 2003 renewal of the Water Quality Certification was amended in September 2006. The amended Certification allowed for maintenance clearing activities in earth-bottom channel reaches within the County of Los Angeles. The amended Certification expired on March 15, 2007.

14. On March 14, 2007, a Certification application package was submitted with attachments requesting renewal and amendment of the Certification. LACFCD requested to renew and further amend the Certification to include additional channel reaches and modify current Maintenance Plans. The application was deemed complete on July 10, 2008.
15. The amended Certification was extended by the Regional Board by letter on September 10, 2007 until March 15, 2008, and extended by letter again on August 29, 2008 until January 31, 2009.
16. The Regional Board letter of August 29, 2008, which extended the Certification, required certain information be submitted to the Board by November 14, 2008. To wit:

By this letter, we require the County to submit to us a technical report with a reach by reach list of all the reaches proposed to be included in the renewed Certification with a hydrologic analysis of each reach and a assessment of the biological functions and values for each reach. This report shall be submitted by November 14, 2008 which will ensure we can complete the renewed certification in timely manner.

The required information was not submitted.

17. A tentative Certification, "99-011, 2009 renewal" was released for public comment on July 6, 2009. Written comments were accepted until 5:00 p.m. on August 5, 2009. Response to comments and a revised tentative Certification were prepared and published on the Regional Board website.
18. The Certification "99-011, 2009 renewal" was unable to be issued by the Regional Board because more than one year had passed from submission of a complete application (CWA SEC. 401. [33 U.S.C. 1341] paragraph (1). Accordingly, pursuant to Federal Law, LACFCD was authorized to proceed pursuant to Nationwide Permit No. 31 without conditions imposed by the Regional Board in the permit. To ensure compliance with State Water Quality Standards, the Basin Plan and other applicable Regional and State policies for Water Quality Control, these waste discharge requirements are adopted to regulate LACFCD's earth-bottom channel maintenance activities. The channel clearing activities continue to be regulated under and must separately comply with the provisions of LACFCD's CWA Section 404 permit and the CDFG SAA.
19. These Waste Discharge Requirements include 10 new channel reaches in addition to the reaches previously included in the Certification, including two (2) channel reaches with 401 Certifications recently issued to a developer that are now being transferred to LACFCD for future maintenance activities. These Waste Discharge Requirements also include the deletion of several reaches previously covered by the Certification that are no longer earth-bottom channels.

20. The current CWA Section 404 permit, Nationwide Permit 31, issued by the ACOE authorizes maintenance in 91 channels. If LACFCD obtains a CWA Section 404 permit for the additional channels covered by this WDR then this WDR will also articulate the Regional Board's necessary requirements to ensure that the discharge of dredge or fill material is protective of State Water Quality Standards and this WDR will act as a CWA Section 401 Water Quality Certification for channel maintenance as described herein, for those channels.
21. Pursuant to section 3860, Title 23, California Code of Regulations (23 CCR), the following three standard conditions shall apply to these new reaches:
  - a. this certification action is subject to modification or revocation upon administrative or judicial review, including review and amendment pursuant to section 13330 of the California Water Code and 23 CCR section 3867 et seq.;
  - b. this certification action is not intended and shall not be construed to apply to any activity involving a hydroelectric facility and requiring a Federal Energy Regulatory Commission (FERC) license or an amendment to a FERC license unless the pertinent certification application was filed pursuant to 23 CCR subsection 3855(b) and the application specifically identified that a FERC license or amendment to a FERC license for a hydroelectric facility was being sought;
  - c. this certification is conditioned upon total payment of any fee required pursuant to 23 CCR division 3, chapter 28, and owed by the applicant.
22. Neither this WDR, nor the previous Certification, authorize any new construction or modification of flood control facilities.
23. LACFCD developed a Maintenance Plan for the Annual Clearing of Earth-Bottom Control Channels in 1999 in conjunction with County ACOE, CDFG and Regional Board. The current Maintenance Plan to which the ACOE, CDFG, Regional Board and LACFCD all agree is the 1999 Maintenance Plan.
24. Watersheds included in this WDR are Los Angeles River, San Gabriel River, Santa Clara River, Malibu Creek, and Dominguez Channel. Los Angeles County Department of Public Works has directed the development of or participated in the development of Master Plans for each of these watersheds.

The Los Angeles River Master Plan was completed and adopted by the County of Los Angeles Board of Supervisors in 1996. The Los Angeles River Master Plan created a multi-objective program for the river. This plan recognizes the River's important purpose for flood protection, and it advocates for environmental enhancement, recreational opportunities, and economic development. In addition, the Los Angeles River Revitalization Master Plan was completed in April 2007 with a vision of the future of the

Los Angeles River. The plan was developed with the participation and funding from the County.

The San Gabriel River Corridor Master Plan was completed in June 2006 for the County of Los Angeles Department of Public Works to enhance habitat, recreational and open space resources along the river in a manner compatible with flood and water management.

The Santa Clara River Enhancement and Management Plan (SCREMP) completed in 2005 is a guidance document for the preservation, enhancement, and sustainability of the resources that occur within the 500-year floodplain limits of the Santa Clara River mainstem. This plan was prepared for the Ventura County Watershed Protection District and the Los Angeles County Department of Public Works.

The Malibu Creek Watershed Council developed the 1995 Malibu Creek Watershed Natural Resources Plan and other studies to protect and preserve the health of the Malibu Creek Watershed. Los Angeles County Department of Public Works is a partner in the Watershed Council.

The Dominguez Watershed Management Master Plan was developed for the County of Los Angeles Department of Public Works in 2004. The Plan provides for the protection, enhancement, and restoration of the environment and beneficial uses of the Dominguez Watershed.

The Los Angeles River flows 51 miles from the western end of the San Fernando Valley to the Pacific Ocean at Long Beach and includes several major tributaries, Tujunga Wash, Burbank Western Channel, Arroyo Seco, Rio Hondo, and Compton Creek. The Los Angeles River watershed comprises an area of about 834 square miles. Of this area, the incorporated cities and unincorporated portion of Los Angeles County comprise 599 square miles. The remaining acreage consists of the Los Angeles National Forest and other uses.

The San Gabriel River watershed comprises a 682 square mile area of eastern Los Angeles County and has a main channel length of approximately 58 miles. It originates in the San Gabriel Mountains and flows through heavily developed areas before emptying into the Pacific Ocean in Long Beach. The main tributaries of the river are Walnut Creek, San Jose Creek, and Coyote Creek. In the middle of the watershed are large spreading grounds used for groundwater recharge. The watershed is hydraulically connected to the Los Angeles River through the Whittier Narrows Reservoir (occurring mostly during high storm flows).

The Santa Clara River is approximately 100 miles and the watershed comprises approximately 1,200 sq. mi. The river originates on the northern slope of the San Gabriel Mountains in Los Angeles County, traverses Ventura County, and flows into the Pacific Ocean halfway between the cities of San Buenaventura and Oxnard. Large tributaries

include Sespe, Piru and Santa Paula Creeks and a lagoon exists at the mouth of the river. Land use is predominately open space with the mainstem of the river surrounded by residential, agriculture, and some industrial uses. The Santa Clara River is the largest river system in southern California that remains in a relatively natural state; this is a high quality natural resource for much of its length.

The Malibu Creek watershed comprises 109 square miles. The watershed extends from the Santa Monica Mountains and adjacent Simi Hills to the Pacific Ocean at Santa Monica Bay. Several creeks and lakes occur in the upper portions of the watershed, and these ultimately drain into Malibu Creek at the downstream end of the watershed. Malibu Creek drains into Malibu Lagoon, a 13-acre tidal lagoon.

The Dominguez Channel watershed is 133 square miles. This watershed includes the Los Angeles and Long Beach Harbors. The Dominguez Channel is 15 miles long. The watershed also includes Wilmington Drain, which empties into Machado Lake and other drainages which drain directly to the Los Angeles and Long Beach Harbors. Ninety-one percent of the land area in the watershed is developed.

### **FEMA Levee Certification**

25. Currently, LACFCD is a participating community in the National Flood Insurance Program (NFIP). The Federal Emergency Management Agency (FEMA) administers the NFIP, identifies flood hazards, assesses flood risks, and provides appropriate flood hazard and risk information to communities. This information is provided through Flood Insurance Rate Maps (FIRMs). FEMA is currently updating these maps and modernizing FIRMs. This effort is called Flood Map Modernization or Map Mod.
26. FEMA has required all levee owners to certify their levees before mapping them in Map Mod. Property owners in the communities protected by these levees have a 1-percent-annual-chance (100-year flood) level of flood protection and will likely not be required to secure flood insurance by lenders.
27. LACFCD has undertaken the effort to certify 65 miles of levees in Los Angeles County. LACFCD is the lead for Compton Creek (partially, with ACOE), San Gabriel River, Coyote Creek, Dominguez Channel, Santa Clara River, and Los Cerritos Channel.
28. The levee certification consists of three main technical components:
  1. Hydraulic analysis;
  2. Subsurface soil exploration and geotechnical/structural (design) analysis; and
  3. Formal Operation and Maintenance (O & M) Plan and Report.
29. The completed certification work has been submitted. FEMA may accredit the levee systems, where appropriate, and present the updated, accurate flood hazard and risk information on the maps and related documents.



30. In order to obtain FEMA certification for the levees, LACFCD is required to demonstrate that maintenance of the channels will alleviate flood hazard conditions to the adjacent residents.

IT IS HEREBY ORDERED that the Los Angeles County Flood Control District, in order to meet the provisions contained in Division 7 of the California Water Code and regulations adopted thereunder, shall comply with the following, pursuant to authority under Cal. Water Code Sections 13263 and 13267.

**Permitted Activities**

31. LACFCD proposes to clear vegetation and debris from 99 earth-bottom channel reaches in order to provide flood control and protect human health and property.
32. The 99 channels include a total of 45 miles of waterways throughout Los Angeles County and approximately 787 acres of jurisdictional waters of the United States.
33. The reaches listed in Table 1 are included under this WDR. This list is consistent with LACFCD list updated and sent to the Regional Board on July 6, 2009 and with the list in the ACOE permit dated September 8, 2008 (with exceptions noted).

**Table 1. Reaches Included**

	Name	County Reach No.	Hydro -Unit No.	Beneficial Uses	Length (ft)	Area (acre)
<b>Los Angeles River Watershed</b>						
1	Bell Creek	1	405.21	MUN, GWR, REC-1, REC-2, WARM, WILD	196	0.90
2	Dry Canyon Creek	2	405.21	MUN, GWR, REC-1, REC-2, WARM, WILD.	1546	1.24
3	Santa Susana Creek, tributary to Browns Canyon Creek	3	405.21	MUN, GWR, REC-1, REC-2, WARM, WILD	75	0.06
4	Browns Canyon Creek	4	405.21	MUN, GWR, REC-1, REC-2, WARM, WILD.	1243	3.00
5	Caballero Creek, West Fork	5	405.21	MUN, GWR, REC-1, REC-2, WARM, WILD	652	1.30
6	Caballero Creek M.C.I., East Fork	6	405.21	MUN, GWR, REC-1, REC-2, WARM, WILD	160	0.35

	Name	County Reach No.	Hydro -Unit No.	Beneficial Uses	Length (ft)	Area (acre)
7	Bull Creek	7	405.21	MUN, GWR, REC-1, REC-2, WARM, WILD	2602	5.61
8	Tributary to the Sepulveda Flood Control Basin Project No. 470 outlet	8	405.21	MUN, GWR, REC-1, REC-2, WARM, WILD, WET	529	0.30
9	Tributary to the Sepulveda Flood Control Basin Project No.106	9	405.21	MUN, GWR, REC-1, REC-2, WARM, WILD, WET	120	0.12
10	Tributary to the Sepulveda Flood Control Basin Project No. 469	10	405.21	MUN, GWR, REC-1, REC-2, WARM, WILD, WET.	4194	7.12
11	Haines Canyon Creek	12	405.23	MUN, GWR, REC-1, REC-2, WARM, WILD, RARE	437	0.40
12	Tributary to Hansen Lake Project No. 5215 Unit1	13	405.23	MUN, GWR, REC-1, REC-2, WARM, WILD, RARE	537	0.55
13	May Canyon Creek	14	405.22	MUN, GWR, REC-1, REC-2, WARM, WILD, RARE	690	0.63
14	Pacoima Wash	15	405.21	MUN, GWR, REC-1, REC-2, WARM, WILD, RARE.	4762	5.25
15	Verdugo Wash-Las Barras Canyon channel inlet	16	405.24	MUN, GWR, REC-1, REC-2, WARM, WILD.	130	0.07
16	Sheep Corral Channel, tributary to Verdugo Wash	17	405.24	MUN, GWR, REC-1, REC-2, WARM, WILD.	300	0.14
17	Engleheard Channel, tributary to Verdugo Wash	18	405.24	MUN, GWR, REC-1, REC-2, WARM, WILD	800	1.10
18	Pickens Canyon, tributary to Verdugo Wash,	19	405.24	MUN, GWR, REC-1, REC-2, WARM, WILD	2406	3.42
19	Webber Channel, tributary to Halls Canyon Channel	20	405.24	MUN, IND, PROC, GWR, REC-1, REC-2, WARM, WILD	115	0.13

	Name	County Reach No.	Hydro -Unit No.	Beneficial Uses	Length (ft)	Area (acre)
20	Webber Channel (main channel inlet at bridge), tributary to Halls Canyon Channel	21	405.24	MUN, IND, PROC, GWR, REC-1, REC-2, WARM, WILD	25	0.03
21	Halls Canyon Channel	22	405.24	MUN, IND, PROC, GWR, REC-1, REC-2, WARM, WILD	2290	2.63
22	Compton Creek	24	405.15	MUN, GWR, REC-1, REC-2, WARM, WILD, WET	11000	30.30
23	Los Angeles River	25	405.12	MUN, IND, PROC, GWR, NAV, REC-1, REC-2, COMM, WARM, EST, MAR, WILD, RARE, MIGR, SPWN, SHELL, WET	4800	56.20
totals:					39609	121
<b>Dominguez Channel Watershed</b>						
24	Tributary to Dominguez Channel Project No. 74	26	405.12	MUN, NAV, REC-1, REC-2, COMM, WARM, EST, MAR, WILD, RARE, MIGR, SPWN.	900	0.35
25	Wilmington Drain, tributary to Harbor Lake	27	405.12	MUN, REC-1, REC-2, WARM, WILD, RARE, WET.	3584	7.87
totals:					4484	8
<b>Malibu Creek Watershed</b>						
26	Triunfo Creek	28	404.25	MUN, GWR, REC-1, REC-2, WARM, WILD, RARE	474	23.00
27	Las Virgenes Creek	29	404.22	MUN, REC-1, REC-2, WARM, COLD, WILD, RARE, MIGR, SPWN, WET	371	1.16
28	Stokes Canyon Channel, tributary to Las Virgenes Creek	32	404.22	MUN, REC-1, REC-2, WARM, COLD, WILD, RARE, MIGR, SPWN, WET	2255	1.40
29	Medea Creek (PD T1378)	33	404.23	MUN, GWR, REC-1, REC-2, WARM, COLD, WILD, RARE, WET.	946	0.69
30	Medea Creek (PD T1005) Main Channel Outlet	34	404.23	MUN, GWR, REC-1, REC-2, WARM, COLD, WILD, RARE, WET	405	0.19

	Name	County Reach No.	Hydro -Unit No.	Beneficial Uses	Length (ft)	Area (acre)
31	Medea Creek under Route 101	35	404.23	MUN, GWR, REC-1, REC-2, WARM, COLD, WILD, RARE, WET	85	0.14
32	Cheseboro Main Channel Inlet, tributary to Medea Creek,	36	404.23	MUN, GWR, REC-1, REC-2, WARM, COLD, WILD, RARE, WET	56	0.08
33	Medea Creek, downstream of Agoura Road	37	404.23	MUN, GWR, REC-1, REC-2, WARM, COLD, WILD, RARE, WET	170	0.47
34	Lindero Creek	38	404.23	MUN, REC-1, REC-2, WARM, WILD	187	0.19
totals:					4949	27
<b>San Gabriel River Watershed</b>						
35	San Gabriel River, Beatty Channel Outlet	39	405.42	MUN, IND, PROC, AGR, GWR, REC-1, REC-2, WARM, COLD, WILD, RARE	145	0.32
36	San Gabriel River, downstream of Santa Fe dam	40	405.41	MUN, GWR, REC-1, REC-2, WARM, WILD, RARE	31370	254.22
37	Walnut Creek	41	405.41	MUN, GWR, REC-1, REC-2, WARM, WILD, WET.	5438	40.90
38	San Jose Creek 1000' downstream from end of concrete at COE Station 87+25.00	42	405.41	MUN, GWR, REC1, REC2, WILD, WET	80	2.75
39	San Gabriel River – upper	43	405.42	MUN, IND, PROC, AGR, GWR, REC-1, REC-2, WARM, COLD, WILD, RARE	6500	74.61
40	San Gabriel River, Rubber Dams	44	405.42	MUN, IND, PROC, AGR, GWR, REC-1, REC-2, WARM, COLD, WILD, RARE	31900	175.76
41	Inlet Walnut Creek	98	405.41	MUN, GWR, REC-1, REC-2, WARM, WILD, WET	30	0.03
totals:					75463	549
<b>Santa Clara River Watershed</b>						
42	Sand Canyon, Main Channel Inlet, tributary to the Santa Clara	45	403.51	MUN, IND, PROC, AGR, GWR, FRSH, REC-1, REC-2, WARM, WILD, RARE, WET	102	0.05

	Name	County Reach No.	Hydro -Unit No.	Beneficial Uses	Length (ft)	Area (acre)
	River					
43	Main Channel Outlet, tributary to the Santa Clara River,	46	403.51	MUN, IND, PROC, AGR, GWR, FRSH, REC-1, REC-2, WARM, WILD, RARE, WET	80	0.06
44	Santa Clara River (PD 1733)	47	403.51	MUN, IND, PROC, AGR, GWR, FRSH, REC-1, REC-2, WARM, WILD, RARE, WET	1656	0.76
45	Mint Canyon Channel, Sierra Hwy & Adon Ave, tributary to the Santa Clara River,	48	403.51	MUN, IND, PROC, AGR, GWR, FRSH, REC-1, REC-2, WARM, WILD.	1800	3.10
46	Mint Canyon Channel, Adon Ave & Scherzinger, tributary to the Santa Clara River	49	403.51	MUN, IND, PROC, AGR, GWR, FRSH, REC-1, REC-2, WARM, WILD	394	0.68
47	Mint Canyon Channel, Solomint & Soledad, tributary to the Santa Clara River	50	403.51	MUN, IND, PROC, AGR, GWR, FRSH, REC-1, REC-2, WARM, WILD, RARE, WET	669	1.54
48	Mint Canyon Channel, (PD 1894)/Santa Clara River, tributary to the Santa Clara River,	51	403.51	MUN, IND, PROC, AGR, GWR, FRSH, REC-1, REC-2, WARM, WILD	932	6.40
49	Sierra Hwy Rd Drainage, tributary to the Santa Clara River	52	403.51	MUN, IND, PROC, AGR, GWR, FRSH, REC-1, REC-2, WARM, WILD.	880	0.40
50	Santa Clara River Non-main Channel. (PD 832) 25' downstream of Sierra Hwy	53	403.51	MUN, IND, PROC, AGR, GWR, FRSH, REC-1, REC-2, WARM, WILD, RARE, WET	45	0.03
51	Santa Clara River Non-main Channel. (PD 832) 821' downstream of Sierra Hwy	54	403.51	MUN, IND, PROC, AGR, GWR, FRSH, REC-1, REC-2, WARM, WILD, RARE, WET	298	0.31

	Name	County Reach No.	Hydro -Unit No.	Beneficial Uses	Length (ft)	Area (acre)
52	Santa Clara River Main Channel, (PD's 910, 1758,1562 unit 2)	55	403.51	MUN, IND, PROC, AGR, GWR, FRSH, REC-1, REC-2, WARM, WILD, RARE, WET	3014	-
53	Santa Clara River Main Channel. (PD 832)	56	403.51	MUN, IND, PROC, AGR, GWR, FRSH, REC-1, REC-2, WARM, WILD, RARE, WET	452	0.47
54	Whites Canyon, tributary to Santa Clara River	57	403.51	MUN, IND, PROC, AGR, GWR, FRSH, REC-1, REC-2, WARM, WILD, RARE, WET	696	2.64
55	Santa Clara River Main Channel (PD 374)	58	403.51	MUN, IND, PROC, AGR, GWR, FRSH, REC-1, REC-2, WARM, WILD, RARE, WET	2064	-
56	Santa Clara River Main Channel (PD 1339 & 374)	60	403.51	MUN, IND, PROC, AGR, GWR, FRSH, REC-1, REC-2, WARM, WILD, RARE, WET..	3258	-
57	Santa Clara River Main Channel (PD 659)	61	403.51	MUN, IND, PROC, AGR, GWR, FRSH, REC-1, REC-2, WARM, WILD, RARE, WET	1634	1.50
58	Santa Clara River Main Channel (PD 659 & 754)	62	403.51	MUN, IND, PROC, AGR, GWR, FRSH, REC-1, REC-2, WARM, WILD, RARE, WET.	3032	2.80
59	Oak Ave Rd Drainage, tributary to Santa Clara River,	63	403.51	MUN, IND, PROC, AGR, GWR, FRSH, REC-1, REC-2, WARM, WILD, RARE, WET	900	0.85
60	Soledad Canyon Road drain, tributary to Santa Clara River	64	403.51	MUN, IND, PROC, AGR, GWR, FRSH, REC-1, REC-2, WARM, WILD, RARE, WET	577	1.03
61	Santa Clara River Main Channel (PD 1538)	66	403.51	MUN, IND, PROC, AGR, GWR, FRSH, REC-1, REC-2, WARM, WILD, RARE, WET.	711	1.04
62	Bouquet Canyon, Upper	67	403.51	MUN, IND, PROC, AGR, GWR, FRSH, REC-1, REC-2, WARM, COLD, WILD, SPWN, WET	6176	16.30
63	Bouquet Canyon, Middle	69	403.51	MUN, IND, PROC, AGR, GWR, FRSH, REC-1, REC-2, WARM, COLD, WILD, SPWN, WET	6812	17.97

	Name	County Reach No.	Hydro -Unit No.	Beneficial Uses	Length (ft)	Area (acre)
64	Bouquet Canyon, Lower [not covered by Sept 8, 2008 ACOE permit]	70	403.51	MUN, IND, PROC, AGR, GWR, FRSH, REC-1, REC-2, WARM, COLD, WILD, SPWN, WET	2954	-
65	Santa Clara River Main Channel (PD 1946)	71	403.51	MUN, IND, PROC, AGR, GWR, FRSH, REC-1, REC-2, WARM, WILD, RARE, WET.	346	1.01
66	South Fork of the Santa Clara River, Smizer Ranch	72	403.51	MUN, IND, PROC, AGR, GWR, FRSH, REC-1, REC-2, WARM, WIL	100	0.14
67	Wildwood Canyon Channel MCI (PD T361), tributary to the South Fork of the Santa Clara River	73	403.51	MUN, IND, PROC, AGR, GWR, FRSH, REC-1, REC-2, WARM, WILD	1	0.05
68	Wildwood Canyon Channel (PD T361), tributary to the South Fork of the Santa Clara River	74	403.51	MUN, IND, PROC, AGR, GWR, FRSH, REC-1, REC-2, WARM, WILD.	116	0.02
69	South Fork of the Santa Clara River (PD's 725, 916, 1041, &1300)	75	403.51	MUN, IND, PROC, AGR, GWR, FRSH, REC-1, REC-2, WARM, WILD.	13965	-
70	Pico Canyon (PD 813), tributary to the South Fork of the Santa Clara River	76	403.51	MUN, IND, PROC, AGR, GWR, FRSH, REC-1, REC-2, WARM, WILD.	4120	4.26
71	Newhall Creek Outlet, tributary to the South Fork of the Santa Clara River	77	403.51	MUN, IND, PROC, AGR, GWR, FRSH, REC-1, REC-2, WARM, WILD.	2136	6.29
72	Placerita Creek, tributary to the South Fork of the Santa Clara River	78	403.51	MUN, IND, PROC, AGR, GWR, FRSH, REC-1, REC-2, WARM, WILD	440	1.16
73	South Fork of the Santa Clara River, Valencia Blvd Bridge Stabilizer	79	403.51	MUN, IND, PROC, AGR, GWR, FRSH, REC-1, REC-2, WARM, WILD	167	1.17

	Name	County Reach No.	Hydro -Unit No.	Beneficial Uses	Length (ft)	Area (acre)
74	South Fork of the Santa Clara River (PD's 1947 & 1946)	80	403.51	MUN, IND, PROC, AGR, GWR, FRSH, REC-1, REC-2, WARM, WILD	2804	8.18
75	Santa Clara River Main Channel (PD 2278)	82	403.51	MUN, IND, PROC, AGR, GWR, FRSH, REC-1, REC-2, WARM, WILD, RARE, WET.	865	4.80
76	Violin Canyon, tributary to Castaic Creek,	86	403.51	MUN, IND, PROC, AGR, GWR, FRSH, REC-1, REC-2, WARM, WILD, RARE	946	1.30
77	Old Road Drain Outlet, tributary to Castaic Creek	87	403.51	MUN, IND, PROC, AGR, GWR, FRSH, REC-1, REC-2, WARM, WILD, RARE.	240	0.19
78	Hasley Canyon Channel Upper (PD T1496)	88	403.51	MUN, IND, PROC, AGR, GWR, FRSH, REC-1, REC-2, WARM, WILD, RARE, WET.	1085	0.42
79	Tributary to Santa Clara River, Hasley Canyon South Fork	89		MUN, IND, PROC, AGR, GWR, FRSH, REC-1, REC-2, WARM, WILD, RARE, WET.	341	0.28
80	Tributary to Santa Clara River, Hasley Canyon Lower (North Fork)	90	403.51	MUN, IND, PROC, AGR, GWR, FRSH, REC-1, REC-2, WARM, WILD, RARE, WET.	1,189	0.68
81	tributary to Santa Clara River, San Martinez Chiquito Canyon, Kenington Road	91	403.51	MUN, IND, PROC, AGR, GWR, FRSH, REC-1, REC-2, WARM, WILD, RARE, WET.	530	0.31
82	tributary to Santa Clara River, San Martinez Chiquito Canyon, North Fork	92	403.51	MUN, IND, PROC, AGR, GWR, FRSH, REC-1, REC-2, WARM, WILD, RARE, WET.	637	0.29
83	Tributary to Santa Clara River, San Martinez Chiquito Canyon, Kenington Road /Val Verde Park	93	403.51	MUN, IND, PROC, AGR, GWR, FRSH, REC-1, REC-2, WARM, WILD, RARE, WET.	634	0.56
84	Tributary to Santa Clara River, San Martinez Chiquito Canyon, Val Verde Park/Madison Street	94	403.51	MUN, IND, PROC, AGR, GWR, FRSH, REC-1, REC-2, WARM, WILD, RARE, WET.	2,445	1.57



	Name	County Reach No.	Hydro -Unit No.	Beneficial Uses	Length (ft)	Area (acre)
85	Little Rock Wash, Project No. 1224 from Avenue T to Confluence of Little Rock Creek	95	403.55	MUN, AGR, GWR, REC1, REC2, WARM, WILD.	1,883	7.95
86	Arroyo Calabasas PD 1591	96	405.21	MUN, REC-1, REC-2, WARM, WILD	320	0.92
87	Tributary to Castaic Creek PD 1982	97	403.51	MUN, IND, PROC, AGR, GWR, FRSH, REC-1, REC-2, WARM, WILD, RARE	2,000	2.30
88	Kagel Canyon Creek	99	405.23	MUN, GWR, REC-1, REC-2, WARM, WILD	4858	1.67
89	Dry Canyon Creek	100	405.21	MUN, GWR, REC-1, REC-2, WARM, WILD	60	0.05
90	Violin Canyon Tributary to Castaic, (PD 1707 & 2312) [not covered by Sept 8, 2008 ACOE permit]	101	403.51	MUN, IND, PROC, AGR, GWR, FRSH, REC-1, REC-2, WARM, WILD, RARE	1817	
91	Violin Canyon Tributary to Castaic, (PD 2275) [not covered by Sept 8, 2008 ACOE permit]	102	403.51	MUN, IND, PROC, AGR, GWR, FRSH, REC-1, REC-2, WARM, WILD, RARE	978	
92	Bouquet Canyon Channel (PD 2225)	103	403.51	MUN, IND, PROC, AGR, GWR, FRSH, REC-1, REC-2, WARM, COLD, WILD, SPWN, WET	1824	
93	Castaic Creek (PD 2441 Units 1 & 2) [not covered by Sept 8, 2008 ACOE permit]	104	403.51	MUN, IND, PROC, AGR, GWR, FRSH, REC-1, REC-2, WARM, WILD, RARE.	2186	
94	San Francisquito Canyon Channel (PD 2456) [not covered by Sept 8, 2008 ACOE permit]	105	403.51	MUN, IND, PROC, AGR, GWR, FRSH, REC-1, REC-2, WARM, WILD, RARE; SPWN; WET.	833	
95	Caustic Drain Outlet	106	403.51	MUN, IND, PROC, AGR, GWR, FRSH, REC-1, REC-2, WARM, WILD, RARE	147	

	Name	County Reach No.	Hydro -Unit No.	Beneficial Uses	Length (ft)	Area (acre)
96	The Old Road Channel (RMD Channel) [not covered by Sept 8, 2008 ACOE permit]	107	403.51	MUN, IND, PROC, AGR, GWR, FRSH, REC-1, REC-2, WARM, WILD, RARE, WET	943	
97	Pico Canyon ( PD 2528) [not covered by Sept 8, 2008 ACOE permit]	108	403.51	MUN, IND, PROC, AGR, GWR, FRSH, REC-1, REC-2, WARM, WILD, RARE, WET.	2910	
98	Santa Clara River - S. Bank W. of Mcbean Pkwy MTD1510 [not covered by Sept 8, 2008 ACOE permit]	109	403.51	MUN, IND, PROC, AGR, GWR, FRSH, REC-1, REC-2, WARM, WILD, RARE, WET	371	
99	Hasley Canyon Channel(PD2262) [not covered by Sept8, 2008 ACOE permit]	110	403.51	MUN, IND, PROC, AGR, GWR, FRSH, REC-1, REC-2, WARM, WILD, RARE, WET	3736	
totals:					97109	104

Municipal and Domestic Supply (MUN), Agricultural Supply (AGR), Industrial Process Supply (PROC), Industrial Service Supply (IND), Ground Water Recharge (GWR), Freshwater Replenishment (FRSH), Navigation (NAV), Contact (REC-1) and Non-contact Recreation (REC-2), Commercial and Sport Fishing (COMM), Warm Freshwater Habitat (WARM), Cold Freshwater Habitat (COLD), Estuarine Habitat (EST), Wetland Habitat (WET), Marine Habitat (MAR), Wildlife Habitat (WILD), Rare, Threatened, or Endangered Species Habitat (RARE), Migration of Aquatic Organisms (MIGR), Spawning, Reproduction and/or Early Development (SPWN), Shellfish Harvesting (SHELL)

34. Channel reaches identified as County Reach numbers 11, 23, 30, 31, 59, 65, 68, 81, 83, 84, and 85 are not included in this WDR and shall be removed from the Approved Maintenance Plan. Any required maintenance in these channels will be permitted or certified separately. This is reflected in Table 1.

35. Under this WDR, ten (10) new reaches will be included and are reflected in Table 1 and added to the Approved Maintenance Plan, described below:

**1) Reach 101 - Violin Canyon (PD 2312)**

This reach is located east of Interstate 5 and west of Emerald Lane in the community of Castaic in unincorporated Los Angeles County. The reach is within the Castaic Creek Watershed. The upstream limit of the reach is 2,637 feet upstream of Lake Hughes Road

and the downstream limit of the reach is 820 feet upstream of Lake Hughes Road. This reach is approximately 1,817 feet in length.

**2) Reach 102 - Violin Canyon (PD 2275)**

This reach is located south of West Highland Court, east of adjacent open space, north of Oak Valley Road, and west of Sierra Oak Trail and Interstate 5 in the community of Castaic in unincorporated Los Angeles County. The reach is located within the Castaic Creek Watershed. The reach upstream limit is 1,072 feet upstream of the downstream face of Sierra Oak Trail and the downstream limit is 94 feet upstream of the downstream face of Sierra Oak Trail. This reach is approximately 978 feet in length.

**3) Reach 103 - PD 2225 - Bouquet Canyon Channel (File No. 04-162)**

This channel reach was transferred from a private housing developer to LACFCD for maintenance. The reach was previously approved for maintenance under File No. 04-162, and will now be included under this WDR.

**4) Reach 104 - Castaic Creek (PD 2441 UNIT 2)**

This reach is located in Castaic Creek between Hwy 126 and Hasley Canyon Road, and borders the length of Hancock Pkwy. (Parcel Map No. 17949) and the developer is Newhall Land and Farm. LACFCD will maintain this channel from 669' upstream of Murfield Lane Centerline to 478' downstream of Turnberry Lane Centerline. To avoid impacts within the mitigation area and also provide flood control protection, LACFCD will *only* perform hand clearing in two 20 by 20 foot areas, around the two existing outlets for a total of 800 square feet of impact. Clearing around the two outlets will allow for inspection of the drainage facilities and will ensure that no vegetation blocks the outlets during storms.

**5) Reach 105 - San Francisquito Canyon Channel (PD 2456)**

The original WDR included maintenance of the San Francisquito Canyon channel from 417 feet upstream of Decoro Drive to 416 feet downstream of Decoro Drive. This channel reach is part of the Natural River Management Plan (NRMP) for the Santa Clara River and its tributaries. In order to comply with the NRMP requirements, LACFCD will only maintain areas 50 feet up and downstream of Decoro Bridge.

In addition, LACFCD will perform the following maintenance activities within the length of the channel as approved under the NRMP requirements: periodic removal of woody vegetation from rip-rap to protect its structural integrity; periodic clearing of storm drain outlets to ensure proper drainage; periodic removal of ponded water that cause odor problems; as-needed repairs of bridges; as-needed repairs of bank protection; and as-needed clearing of vegetation from water quality filters and treatment basins.

**6) Reach 106 - Castaic Drain Outlet (RMD Channel)**

This reach is located south of Ridge Route Road, west of Castaic Regional Sports Complex, north of Castaic Road and Tapia Canyon Road, east of Castaic Road and Interstate 5 in the community of Castaic in unincorporated Los Angeles County. The

reach is located within the Santa Clara River Watershed. The reach upstream limit is at the toe of the grouted rip-rap apron and the downstream limit is 147 feet downstream of the grouted rip-rap apron. This reach is approximately 147 feet in length. The channel clearing will involve mechanized removal of vegetation along a 12 foot-wide access path aligned along the toe of the east bank, and installation and maintenance of crushed aggregate base on the access path.

**7) Reach 107 - The Old Road Channel (RMD Channel)**

This reach is located south of the intersection of Calgrove Boulevard and The Old Road, west of Interstate 5, east of The Old Road and Towsley Canyon Park in unincorporated Los Angeles County. The reach is located within the Santa Clara River Watershed. The reach upstream limit is 230 feet upstream of the driveway into 24136 The Old Road and the downstream limit is the upstream end of the concrete-lined channel. This reach is approximately 943 feet in length. Hand clearing of vegetation using manual and hand-operated tools will be performed at this reach.

**8) Reach 108 – Pico Canyon Creek (PD 2528) (File 05-205)**

This channel reach was transferred from a developer to LACFCD for maintenance. The reach, previously approved for maintenance under File No. 05-205, will now be included under this WDR.

**9) Reach 109 - Santa Clara River - S. Bank W. of McBean Pkwy (MTD1510):**

This reach is in the Santa Clara River Watershed. This reach has an upstream limit of 371' U/S McBean Pkwy centerline (Latitude: 34.424217; Longitude: 118.563767); and a downstream limit of PD 1946 (Latitude: 34.424106, Longitude: 118.56255). The length is 371 linear feet.

**10) Reach 110 - Hasley Canyon Channel (PD 2262)**

This reach is in the Santa Clara River Watershed. This reach has an upstream limit of PD 2508 (Latitude: 34.451733, Longitude: 118.633603), and a downstream limit of Castaic Creek (Latitude 34.445553, Longitude 118.62425). The length is 3736 linear feet.

36. Unless approved by the Regional Board after results of the Feasibility Study, channel clearing shall not exceed "1997/1998 storm season clearing level" conditions established by the Regional Board, CDFG, and ACOE prior to the 1997 El Niño storm season. This baseline level was utilized to identify the maximum vegetation removal authorized for each reach, and is included in the Maintenance Plan for Annual Clearing Activities, August 2005 (Maintenance Plan).
37. LACFCD shall comply with the specifications of their Mitigation Monitoring Program, and the Maintenance Plan prepared for this maintenance program, or any subsequently approved plans that follow. Only revisions approved by the Regional Board Executive Officer, ACOE and CDFG shall be authorized for this project.

38. Clearing will be either through the use of heavy equipment, including trucks, bulldozers, dump trucks, and front-end loaders, along with other specialized equipment, or in areas where there are sensitive species and native vegetation; clearing shall take place by hand as specified in the approved Maintenance Plan in order to selectively avoid protected resources. Equipment will access the channels by existing access roads.

#### **Additional Activities Permitted**

39. **Maintenance of All Existing Invert Access Ramps**

All existing channel invert access ramps shall be part of the approved annual maintenance for all earth-bottom channel facilities, including new reaches that have been added to the WDR. The invert access ramps, whether constructed with dirt, lined with concrete, or armored with riprap on the sides, are critical structures for access to earth-bottom channel reaches.

Maintenance activities for these ramps shall include inspection, minor maintenance repairs, and storm damage repair and rehabilitation. Storm damage repair and rehabilitation includes restoring ramps that are damaged or washed out during a storm, back to pre-storm conditions.

40. **One-Time Mechanical Sediment & Vegetation Removal for Two (2) Hand Clearing Channel Reaches**

- a.) The approved Maintenance Plan now includes Reach 29 Las Virgenes Creek (PD T1684) MCI as a hand clearing only reach. A one-time mechanical sediment and vegetation clearing, which shall be performed outside of the nesting bird season, is authorized. - A recent fire in 2006 burned the open space conservancy area adjacent to the channel reach. The fire also burned some of the vegetation within the reach. In addition, the reach has not been maintained for several years. Overgrown trees, cattails, and non-native vegetation dominate the channel reach and have impacted the hydraulic capacity of the channel. The reach currently has ponded water.

Due to years of accumulated sediment and excessive growth of root balls, the hydraulic capacity of the channel has diminished. In addition, additional sediment is expected from mudflows from adjacent burned areas during a storm. Therefore, this channel reach requires sediment clearing using mechanical equipment. The mechanical equipment shall sit on top of the access road and reach into the channel and scoop out vegetation and approximately 3-5 feet of accumulated sediment and root balls. This is necessary to remove ponded water and to allow storm flows to flow freely during future storms. LACFCD projects that approximately 462 tons of sediment and vegetation will be removed from this site and that it will take approximately 3 - 5 days to complete the sediment removal within a 370-foot section of the channel. If the expected scope changes, the Executive Officer shall be notified 21 days in advance of clearing activities.

b.) Reach 33 – Medea Creek (PD T1378 u.2) This reach is located south of Laro Drive and northwest of Kanan Road in the City of Agoura Hills. This reach is within the Malibu Creek Watershed. The upstream limit of the reach is 731 feet upstream of Thousand Oaks Boulevard and the downstream limit is 215 feet downstream of Thousand Oaks Boulevard. This reach is approximately 946 feet in length.

41. **Notching Drain Channel Outlets at a 45-Degree Angle from the Outlet to the Middle of the Channel**

Notching and limited vegetation removal from drain channel outlets shall be conducted on reaches where mechanical removal of sediment and vegetation is allowed, and is consistent with the original channel designs. In stream reaches that are approved for mowing or hand removal of vegetation, work on installing notches at 45-degrees and clearing drain channel outlets shall be conducted by hand and shall be consistent with all terms of the Maintenance Plan and WDR.

**Work Plan Notification Protocol**

42. **Notification Protocol and Thresholds for Additional Review**

Pursuant to California Water Code section 13267, LACFCD shall submit an **Annual Workplan** with a schedule of the upcoming reaches proposed for cleanout. The Annual Workplan shall include, at a minimum, the following information: (a) proposed schedule; (b) acreage of areas to be impacted (vegetated and non-vegetated); (c) a description of any existing aquatic resources; (d) site-specific BMPs to be implemented; and (e) proposed application of pesticides. The Discharger shall send the Annual Workplan not later than July 1 each year to the Regional Board Executive Officer and 401 Certification Unit staff, and send notices of changes to the maintenance schedule, and of additional routine maintenance work as the needs are discovered in the field. The Executive Officer may require additional time to review or add additional requirements or require separate permitting for certain activities proposed upon review of the Annual Workplan or notice of additional routine maintenance work; however, if the Executive Officer does not provide any comments, additional requirements or a request for additional review time within 60 days of submittal of the Annual Workplan, or within 15 days of the notice of additional routine maintenance work, LACFCD is authorized to proceed pursuant to the Annual Workplan or its notice of additional routine maintenance work, as proposed.

Routine maintenance may require additional review if the work exceeds certain thresholds of impact. For projects that exceed the following thresholds, the Discharger shall provide information similar to a pre-construction notification for a 401 Water Quality Certification for 60-day review.

*Project Exceeds Original Footprint*

For any work resulting in temporary or permanent impacts within the ordinary high water mark outside the original project boundaries, LACFCD shall submit a new proposed scope of work to the Executive Officer for confirmation that the project areas is within the scope of the WDR and may be required by the Executive Officer to reapply for supplemental WDRs with all pertinent information for consideration.

*Project Deviates from the Pre-Approved Surface Water Diversion Plan*

If water diversion is planned to occur in a manner which deviates from the Pre-Approved Water Diversion Plan, LACFCD shall submit the new plan to the Regional Board Executive Officer for review and approval. The Executive Officer is authorized to approve changes to the Surface Water Diversion Plan provided that it is consistent with this WDR.

For projects exceeding the thresholds above, or for which mitigation may be required, LACFCD shall propose mitigation measures to compensate for loss of waters of the State and wetland functions and values. Mitigation ratios will be determined on a case by case basis as detailed below. Mitigation proposed by LACFCD will require approval by the Executive Officer.

In addition, for maintenance in any reach covered by the WDR as discussed above, the LACFCD is authorized to conduct emergency maintenance provided that notice is provided to the Executive Officer either prior to or as soon as possible following start of the emergency work without a 15-day review period. Emergency is defined as, "a sudden, unexpected, occurrence, involving a clear and imminent danger, demanding immediate action to prevent or mitigate loss of, or damage to, life, health, property, or essential public services. Emergency includes such occurrences as fire, flood, earthquake, or other soil or geologic movement, as well as such occurrences as riot, accident, or sabotage."

**Best Management Practices**

43. All appropriate Best Management Practices (BMPs) shall be implemented in order to avoid impacts to water quality that would result in exceedances of water quality standards. The Project shall not result in indirect impacts to water quality or beneficial uses of downstream water bodies. The Project shall not result in changes in water quality as a result of maintenance activities in downstream water bodies during maintenance, or during operation subsequent to the maintenance activities. The Project shall not result in changes in water quality in the channel that would result in water quality exceedances during periods between maintenance activities, or upon its completion.

**Feasibility Study (Pursuant to California Water Code 13267)**

44. The Regional Board requires the information to be provided in the Feasibility Study to determine that the channel clearing activities have avoided, minimized or appropriately mitigated for effects on the beneficial uses of the affected reaches or to require changes to channel clearing activities to achieve the necessary avoidance, minimization or mitigation. Data and technical ability necessary to conduct the required analyses exists with LACFCD. The required analyses have been split over multiple years to allow LACFCD flexibility in completing the required studies.
45. As part of the on-going assessment of channel conditions and hydraulic capacity, LACFCD shall perform a study of the hydraulic capacity and existing conditions of all reaches covered by this WDR to determine where a potential may exist for native vegetation to remain within the soft-bottom portion of the channel or if additional hydraulic capacity is needed (Feasibility Study). In addition, any channels which may potentially provide restoration opportunities for riparian habitat/vegetation growth shall be identified based on these assessments and a consideration of restoration plans by other agencies. LACFCD shall implement the Feasibility Study process with a schedule of one or more watersheds per year to be analyzed, with completion of all watersheds/studies within six (6) years. LACFCD shall solicit input from stakeholders during Work Plan development and prior to the finalizing the Technical Assessment Report and recommendations.
46. In the first year, the Feasibility Study shall be required for the Los Angeles River Watershed (which includes the main-stem reaches and all tributaries, including Compton Creek, covered by this WDR). The study area shall include any channels directly or indirectly affected by proposed maintenance. Each year, LACFCD and the Regional Board Executive Officer shall determine in which watershed(s) the Feasibility Study shall be conducted in the subsequent year.
47. For each watershed, the Feasibility Study shall include (but not be limited to) the following components:
  - a. Study Workplan
  - b. Technical Assessment Report
  - c. Recommendations
48. **Study Workplans**  
Within five (5) months of WDR issuance, a Workplan for the first watershed shall be submitted to the Regional Board Executive Officer for approval. The plan will include: a detailed plan for a hydraulic analysis of each earth-bottom segment in relation to the conveyance capacity of the upstream and downstream channels, in addition to the Water Quality Monitoring. The hydraulic analysis shall include, but not be limited to, the height and density of vegetation in the earthen channel bottom and its effect on the



conveyance capacity of flood flow in the channel and shall include discussion of changes in expected stream flow in response to requirements of the Los Angeles County Municipal Separate Storm Sewer (MS4) NPDES Permit, Standard Urban Stormwater Mitigation Plans (SUSMPs), Total Maximum Daily Loads (TMDLs) and other pertinent local plans including, but not limited to the Integrated Regional Water Management Plan (IRWMP) (including implementation of, and plans for, increased stormwater infiltration), the City of Los Angeles' Integrated Resources Plan, the relevant watershed master plan and LACFCD's Drought Management Plan. Several reasonable Manning's n should be used in the hydraulic analysis to evaluate the representative height of the channel for flood control and natural habitat purposes and should be in accordance with "Guide for Selecting Manning's Roughness Coefficients for Natural Channels and Flood Plains," United States Geological Survey Water-supply Paper 2339 or other appropriate guidance.

The assessment of biological functions and values of these reaches should be made such that comparisons of habitat type, maturity and extent of native or invasive plants can be made between reaches.

**49. Water Quality Monitoring**

The objectives of the water quality monitoring are to assess BMP effectiveness and to ensure that water quality is not impacted as a result of the proposed maintenance activities, or surface water diversion. BMPs are to be implemented in association with maintenance activities to avoid impacts to water quality which would result in exceedences of water quality standards. As part of the Feasibility Study, water quality assessments within each reach will be required on a one-time basis before, after, and during maintenance clearing activities. Each project reach will require three (3) sampling stations: upstream of project, within project; and downstream of project reach. The testing parameters required will be the same as for Surface Water Diversion.

- pH
- temperature
- dissolved oxygen
- turbidity
- total suspended solids (TSS)

Downstream TSS shall be maintained at ambient levels. Where natural turbidity is between 0 and 50 Nephelometric Turbidity Units (NTU), increases shall not exceed 20%. Where natural turbidity is greater than 50 NTU, increases shall not exceed 10%.

Analyses must be performed using approved US Environmental Protection Agency methods, where applicable.

These constituents shall be measured at least once prior to the maintenance activity and then monitored for on a daily basis during the first week of maintenance activities, and then on a weekly basis, thereafter, until the work is complete. When reaches are within

the watershed designated for a Feasibility Study in a particular year, water quality monitoring should be conducted for those reaches as part of the Feasibility Study and reported with the Technical Assessment Report.

Any exceedances of water quality standards may result in corrective and/or enforcement actions, including increased monitoring and sample collection.

50. **Technical Assessment Report – Hydraulic Water Quality and Geomorphologic Assessment**

Within seven (7) months of Workplan approval, a Technical Assessment Report shall be submitted and will include a reach-by-reach list of all the reaches included in the subject watershed with a hydraulic analysis of each reach.

This report will also include an assessment of the biological functions and values for each reach and an assessment of water quality as required. For each reach, the report shall address capacity requirements for flood control; design criteria and anticipated limitations; and an analysis either of potential areas where vegetation may remain and areas with the potential for restoration of native vegetation or where justification exists to clear additional vegetated areas. For those areas where vegetation may remain, the technical assessment report should specify the amount(s) and type(s) of native vegetation that could remain in the channel.

51. **Recommendations**

Within seven (7) months of Workplan approval, recommendations shall be submitted to the Regional Board Executive Officer and shall include options for reaches where native vegetation may be allowed to remain or where native vegetation could be re-established. Recommendations shall also include suggested schedules of vegetation removal frequency in order to ensure the maximum habitat preservation, consistent with necessary flood control, is achieved. For recommendations approved by the Executive Officer, LACFCD shall make the necessary changes to the the next years' Work Plan (Annual Work Plan), including proposals for additional BMPs as may be appropriate, and shall submit such changes to the Executive Officer 21 days prior to any clearing activities.

**Regulatory Authority**

52. The Regional Board has determined to regulate the subject discharge of fill materials into waters of the State by issuance of waste discharge requirements (WDRs) pursuant to Section 13263 of the California Water Code (CWC). The Regional Board considers WDRs necessary to adequately address impacts and mitigation to beneficial uses of waters of the State from this Project, to meet the objectives of the California Wetlands

- Conservation Policy (Executive Order W-59-93), and to accommodate and require appropriate changes over the life of the Project.
53. The Regional Board, on June 13, 1994, adopted, in accordance with Section 13240 et seq. of the CWC, a revised Water Quality Control Plan, Los Angeles Region (Basin Plan). This updated and consolidated revised Basin Plan was approved by the State Water Resources Control Board and the Office of Administrative Law on November 17, 1994, and February 23, 1995, respectively. A summary of regulatory provisions is contained in 23 CCR 3912. The Basin Plan defines beneficial uses and water quality objectives for waters of the State, including surface waters and ground waters. This Order is in compliance with the Basin Plan, and amendments thereto.
  54. The goals of the California Wetlands Conservation Policy (Executive Order W-59-93, signed August 23, 1993) include ensuring “no overall loss” and achieving a “...long-term net gain in the quantity, quality, and permanence of wetland acreage and values...” Senate Concurrent Resolution No. 28 states that “[i]t is the intent of the legislature to preserve, protect, restore, and enhance California’s wetlands and the multiple resources which depend on them for benefit of the people of the State.” Section 13142.5 of the CWC requires that the “[h]ighest priority shall be given to improving or eliminating discharges that adversely affect...wetlands, estuaries, and other biologically sensitive areas.”
  55. The California Environmental Quality Act (CEQA) requires all Projects approved by State agencies to be in full compliance with CEQA, and requires a lead agency to prepare an appropriate environmental document (e.g., Environmental Impact Report or Negative Declaration) for such Projects. The Regional Board finds that the proposed activities are categorically exempt pursuant to Section 15301(d) (Existing Facilities) of the California Environmental Quality Act (CEQA)
  56. This Project is filed with the Regional Board under file number 99-011, 2009 WDR.
  57. The Regional Board has notified the LACFCD and other interested agencies and persons of its intent to prescribe WDRs for this discharge.
  58. A tentative WDR was released for public comment on October 12, 2009. Written comments were accepted until 5:00 p.m. on November 12 2009. The deadline was extended for LACFCD until November 25, 2009.
  59. The Board, in a public meeting on February 4, 2009, heard and considered all comments pertaining to the discharge.

### **Prohibitions**

1. Fueling, lubrication, maintenance, operation, and storage of vehicles and equipment shall not result in a discharge or a threatened discharge to waters of the State. At no time shall LACFCD use any vehicle or equipment which leaks any substance that may impact water quality. Staging and storage areas for vehicles and equipment shall be located outside of waters of the State.
2. No construction material, spoils, debris, or any other substances associated with this project that may adversely impact water quality standards, shall be located in a manner which may result in a discharge or a threatened discharge to waters of the State. Designated spoil and waste areas shall be visually marked prior to any excavation and/or construction activity, and storage of the materials shall be confined to these areas.
3. The discharge shall not: a) degrade surface water communities and populations including vertebrate, invertebrate, and plant species; b) promote the breeding of mosquitoes, gnats, black flies, midges, or other pests; c) alter the color, create visual contrast with the natural appearance, nor cause aesthetically undesirable discoloration of the receiving waters; d) cause formation of sludge deposits; or e) adversely affect any designated beneficial uses.

### **Provisions**

4. LACFCD shall submit to this Regional Board 401 Certification Unit staff copies of any other final permits and agreements required for this project, including, but not limited to, the U.S. Army Corps of Engineers' (ACOE) Section 404 Permit and the California Department of Fish and Game's (CDFG) Streambed Alteration Agreement if the permits have not already been submitted. These documents shall be submitted prior to any discharge to waters of the State.
5. LACFCD shall comply with the specifications of their Mitigation Monitoring Program, and the Maintenance Plan, or any subsequently approved plans that follow.
6. Prior to any maintenance activities within the subject reaches, LACFCD shall develop and publish watershed maps which indicate areas of maintenance (impact acreages and types of vegetation impacted) and approximate schedules (including baseline biological surveys, post-surveys and maintenance activity descriptions). This information shall be made publicly available on the LACFCD internet website and be noticed via e-mail notification or other type of direct notification to interested parties prior to any routine maintenance activities. For each reach, the information shall include: (a) the proposed schedule; (b) a description of the reach's existing condition; (c) the area of proposed impact; and (d) a description of any existing aquatic resources (e.g., wetland/riparian vegetation based on readily available information and pre-clearing biological surveys). After submission to the Regional Board Executive Officer, LACFCD will post the

Annual Project and Mitigation Monitoring Reports as described in Provisions 29 and 30, below.

7. The Applicant shall develop and implement a Plan for Hazard Analysis and Critical Control Points (HACCP). This plan may be developed with Regional Board 401 Certification Unit staff assistance in order to implement prevention and control of aquatic nuisance species. The draft plan shall be submitted to the Regional Board 401 Certification Unit staff within two months after issuance of this WDR. Further information regarding the development of the HACCP can be found at: <http://www.anstaskforce.gov/haccp.php>.

8. LACFCD shall comply with all water quality objectives, prohibitions, and policies set forth in the *Water Quality Control Plan, Los Angeles Region (1994)*, as amended.

9. LACFCD shall implement all Best Management Practices as outlined in the Maintenance Plan, including, but not limited to, the following:

Prior to start of any annual maintenance clearing, qualified biologists shall perform pre-clearing biological resource surveys and photo documentation including sensitive/endangered species focused surveys on specific reaches. No work shall commence without confirmation of findings or no findings of sensitive/endangered species from the biologists. These surveys are also meant to minimize impact on any resources that may potentially use or benefit from the channel.

During construction, biologists shall be available for consultation for any issues that may arise.

10. LACFCD and all contractors employed by LACFCD shall have copies of this WDR, the approved Maintenance Plan, and all other regulatory approvals for this project on site at all times and shall be familiar with all conditions set forth therein.
11. All excavation, construction, or maintenance activities shall follow best management practices to minimize impacts to water quality and beneficial uses. Dust control activities shall be conducted in such a manner that will not produce downstream runoff.
12. All waste and/or dredged material removed shall be relocated to a legal point of disposal if applicable. A legal point of disposal is defined as one for which Waste Discharge Requirements have been established by a California Regional Water Quality Control Board, and is in full compliance therewith. Please contact the Land Disposal Unit, at (213) 620-6600 for further information.
13. LACFCD shall implement all necessary control measures to prevent the degradation of water quality from the proposed project in order to maintain compliance with the Basin Plan. The discharge shall meet all effluent limitations and toxic and effluent standards established to comply with the applicable water quality standards and other appropriate

- requirements, including the provisions of Sections 301, 302, 303, 306, and 307 of the Clean Water Act. This WDR does not authorize the discharge by LACFCD for any other activity than specifically described in the current 404 Permit for this project.
14. The Applicant shall allow the Regional Board and its authorized representative entry to the premises, including all mitigation sites, to inspect and undertake any activity to determine compliance with this WDR, or as otherwise authorized by the California Water Code.
  15. Application of pesticides must be supervised by a certified applicator and be in conformance with manufacturer's specifications for use. Compounds used must be appropriate to the target species and habitat. Pesticide utilization shall be in accordance with State Water Resources Control Board Water Quality Order Nos. 2004-0008-DWQ and 2004-0009-DWQ.
  16. The Applicant shall not conduct any routine maintenance activities within waters of the State during a rainfall event. The Applicant shall maintain a **one-day (1-day) clear weather forecast** before conducting any operations within waters of the State. If rain is predicted within 12 hours after operations have begun, activities shall cease temporarily, and protective measures to prevent siltation/erosion shall be implemented and maintained.
  17. The Applicant shall utilize the services of a qualified biologist with expertise in riparian assessments during all construction activities where clearing involves areas to be partially cleared (i.e. some vegetation is to remain in the same reach or in an adjacent reach). The biologist shall be available if necessary during maintenance activities to ensure that all protected areas are marked properly and ensure that no vegetation outside the specified areas is removed. The biologist shall have the authority to stop the work, as necessary, if instructions are not followed. The biologist shall be available upon request from this Regional Board staff for consultation within 24 hours of request of consultation.
  18. No activities shall involve wet excavations (i.e., no excavations shall occur below the seasonal high water table). A minimum **5-foot** buffer zone shall be maintained above the existing groundwater level. If construction or groundwater dewatering is proposed or anticipated, LACFCD shall file a **Report of Waste Discharge** to this Regional Board and obtain any necessary NPDES permits/Waste Discharge Requirements prior to discharging waste. Sufficient time should be allowed to obtain any such permits (generally 180 days). If groundwater is encountered without the benefit of appropriate permits, LACFCD shall cease all activities in the areas where groundwater is present, file a Report of Waste Discharge to this Regional Board, and obtain any necessary permits prior to discharging waste.
  19. All maintenance activities not included in this WDR, and which may require a permit, must be reported to the Regional Board for appropriate permitting. Bank stabilization

and grading, as well as any other ground disturbances, are subject to restoration and revegetation requirements, and may require additional WDR action.

20. Maintenance activities in the Santa Clara River area shall comply with the provisions of the Natural Rivers Management Plan (NRMP). The following provisions apply to soft-bottom channel reaches that are within the jurisdiction of the approved NRMP: a) Periodic clearing of vegetation immediately upstream and downstream of certain existing bridges which were not designed in accordance with the NRMP; b) Periodic removal of woody vegetation from riprap to protect its structural integrity; c) Periodic clearing of storm drain outlets to ensure proper drainage; d) Periodic removal of ponded water that cause odor problems; e) As needed repairs of bridges; f) As-needed repairs of bank protection; and g) As needed clearing of vegetation from water quality filters and treatment basins
21. All surface waters, including ponded waters, shall be diverted away from areas undergoing grading, construction, excavation, vegetation removal, and/or any other activity which may result in a discharge to the receiving water. If surface water diversions are anticipated, LACFCD shall develop and submit a Surface Water Diversion Plan (plan) to the Executive Officer. The plan shall include the proposed method and duration of diversion activities, structure configuration, construction materials, equipment, erosion and sediment controls, and a map or drawing indicating the locations of diversion and discharge points. Contingency measures shall be a part of this plan to address various flow discharge rates. The plan shall be submitted prior to any surface water diversions. If surface flows are present, then upstream and downstream monitoring for the following shall be implemented:
  - pH
  - temperature
  - dissolved oxygen
  - turbidity
  - total suspended solids (TSS)

Downstream TSS shall be maintained at ambient levels. Where natural turbidity is between 0 and 50 Nephelometric Turbidity Units (NTU), increases shall not exceed 20%. Where natural turbidity is greater than 50 NTU, increases shall not exceed 10%.

Analyses must be performed using approved US Environmental Protection Agency methods, where applicable. These constituents shall be measured at least once prior to diversion and then monitored for on a daily basis during the first week of diversion and/or dewatering activities, and then on a weekly basis, thereafter, until the in-stream work is complete.

LACFCD shall submit results of the analyses to the Regional Board, to the attention of the 401 Program Unit, within 30 days of each subsequent sampling event. A map or drawing indicating the locations of sampling points shall be included with each submittal.

- Diversion activities shall not result in the degradation of beneficial uses or exceedance of water quality objectives of the receiving waters. Any such violations may result in corrective and/or enforcement actions, including increased monitoring and sample collection.
22. LACFCD shall restore all areas of TEMPORARY IMPACTS to waters of the United States and all other areas of temporary disturbance outside of areas of maintenance which could result in a discharge or a threatened discharge to waters of the State. Restoration shall include returning areas to pre-project contours and planting with native vegetation, if feasible. Restored areas shall be monitored and maintained with native species as necessary for five years. LACFCD shall implement all necessary Best Management Practices to control erosion and runoff from areas associated with this project.
  23. Prior to clearing of the new reaches, or where additional clearing has been authorized by the Regional Board, LACFCD will document and provide to the Regional Board the amount of riparian vegetation to be removed for maintenance in these reaches and will provide mitigation for each reach.
  24. LACFCD shall provide COMPENSATORY MITIGATION for the new impacts at a **minimum** ratio of 2:1. If ongoing maintenance activities were covered by previous certifications with mitigation, additional mitigation will not be required. LACFCD will propose mitigation for the impacts to new reaches which may include the documentation of mitigation conducted for new reaches under previous certifications.
  25. LACFCD shall submit a Mitigation Plan for approval to this Regional Board Executive Officer and 401 Certification Unit staff for the new permanent impacts at least 60 days prior scheduling clearing to allow for the review and approval of the Mitigation Plan. The Mitigation Plan will specify location, methods, monitoring, performance criteria, reporting and any other pertinent information. Regional Board Executive Officer will approve the plan, require changes and re-submission, or will make modifications to the plan, as appropriate to achieve the no-net-loss policy of Executive Order W-59-93 Channel maintenance which is part of an approved Annual Work Plan can take place even if proposed mitigation for the new reaches is not yet approved.
  26. Mitigation shall take place in the vicinity of the impacted reach, or if not feasible, within the same watershed. If LACFCD does not have available mitigation areas in the same watershed, mitigation may occur in another watershed through in-lieu funding with an approved Mitigation Bank, or through Conservancy Groups such as the Santa Monica Mountains Conservancy upon Executive Officer approval.
  27. All mitigation areas shall be preserved and maintained as habitat in perpetuity.
  28. Pursuant to California Water Code section 13267, LACFCD shall submit to this Regional Board Executive Officer and 401 Certification Unit staff an **Annual Project and Mitigation Monitoring Report (Annual Report)** by May 1<sup>st</sup> of each year for each year



the WDR is in effect. The Annual Reporting outline shall be submitted to the Regional Board within 60 days of the issuance of this WDR. The outline should include all relevant information to meet reporting requirements and also include any technical or field checklists which will be utilized. Upon receipt, the Executive Officer will have 30 days to comment or approve of the Annual Report outline.

29. The Annual Report shall describe in detail all of the project/maintenance activities performed during the previous year and all restoration and mitigation efforts; including percent survival by plant species and percent cover. The Annual Reports shall describe the status of other agreements (e.g., mitigation banking) or any delays in the mitigation process. At a minimum the Annual Reports shall include the following documentation:
- a) Color photo documentation of the immediately pre- and post-project and mitigation site conditions as well as periodic photo documentation of post-project and mitigation site conditions between project activities;
  - b) Narrative and photo documentation of any BMP installations during project maintenance activities and immediately after maintenance activities as well as periodically between maintenance activities. In addition, an evaluation of the effectiveness of BMPs utilized shall be provided based on field observations and water quality monitoring data required.
  - c) Photo documentation of any vegetation left within maintenance areas immediately following maintenance clearing (including acreage);
  - d) Documentation of estimates of volumes of vegetation removed from the project areas;
  - e) Documentation of estimates of volumes of trash removed from the project areas;
  - f) Documentation of estimates of volumes of sediment removed from the project areas;
  - g) Biological information including: baseline biological surveys, and post-surveys;
  - h) Geographical Positioning System (GPS) coordinates in decimal-degrees format outlining the boundary of actual project and new mitigation areas;
  - i) The overall status of project including a detailed schedule of work;
  - j) Copies of all revised permits related to this project.

- k) Water quality monitoring results for each reach compiled in an easy to interpret format.
  - l) A certified Statement of “no net loss” of wetlands associated with this project;
  - m) Discussion of any monitoring activities and exotic plant control efforts;
  - n) Description of all outreach activities in the previous year; and
  - o) A certified Statement from LACFCD that all information reported in the Annual Report is complete and accurate. This Report will include a summary of compliance with all requirements of the WDR.
30. All applications, reports, or information submitted to the Regional Board shall be signed by either a principal executive officer, ranking elected official, or other duly authorized employee.
31. Each and any report submitted in accordance with this WDR shall contain the following completed declaration;

“I declare under penalty of law that this document and all attachments were prepared under my direction or supervision in accordance with a system designed to assure that qualified personnel properly gather and evaluate the information submitted. Based on my inquiry of the person or persons who managed the system or those directly responsible for gathering the information, the information submitted is, to the best of my knowledge and belief, true, accurate and complete. I am aware that there are significant penalties for submitting false information, including the possibility of fine and imprisonment for knowing violations.

Executed on the \_\_\_\_\_ day of \_\_\_\_\_ at \_\_\_\_\_.

\_\_\_\_\_ (Signature)

\_\_\_\_\_ (Title)”

32. All communications regarding this project and submitted to this Regional Board shall identify the Project File Number **99-011 2010 WDR**. Submittals shall be sent to the Executive Officer where identified and to the 401 Certification Unit, Attention: Valerie Carrillo.

33. Any modifications of the proposed project may require submittal of a new Clean Water Act Section 401 Water Quality certification application or WDR application and appropriate filing fee.

**Enforcement:**

34. LACFCD or their agents shall report any noncompliance. Any such information shall be provided verbally to the Executive Officer within 24 hours from the time LACFCD becomes aware of the circumstances. A written submission shall also be provided within five days of the time LACFCD becomes aware of the circumstances. The written submission shall contain a description of the noncompliance and its cause; the period of noncompliance, including exact dates and times, and if the noncompliance has not been corrected; the anticipated time it is expected to continue and steps taken or planned to reduce, eliminate and prevent recurrence of the noncompliance. The Executive Officer, or an authorized representative, may waive the written report on a case-by-case basis if the oral report has been received within 24 hours.
- a) In the event of any violation or threatened violation of the conditions of this WDR, the violation or threatened violation shall be subject to any remedies, penalties, process or sanctions as provided for under State law.
- b) In response to a suspected violation of any condition of this WDR, the State Water Resources Control Board (State Board) or Regional Water Quality Control Board may require the holder of any permit or license subject to this WDR to furnish, under penalty of perjury, any technical or monitoring reports the State Board or Regional Board deems appropriate, provided that the burden, including costs, of the reports shall be a reasonable relationship to the need for the reports and the benefits to be obtained from the reports.
35. After notice and opportunity for a hearing, this Order may be terminated or modified for cause, including, but not limited to:
- a. Violation of any term or condition contained in this Order;
  - b. Obtaining this Order by misrepresentation, or failure to disclose fully all relevant facts;
  - c. A change in any condition that requires either a temporary or permanent reduction or elimination of the authorized reuse;
  - d. Endangerment to public health or environment that can only be regulated to acceptable levels by Order modification or termination.
36. Additional Reports: The Dischargers shall furnish to the Regional Board, upon request, copies of records required to be kept by this Order.

37. Discharge a Privilege: All discharges of waste into the waters of the State are privileges, not rights. In accordance with Water Code section 13263(g), these requirements shall not create a vested right to continue to discharge and are subject to rescission or modification.
38. Term: This Order shall remain in effect for a period of 5 years. Should LACFCD wish to continue maintenance activities for a period of time in excess of 5 years, LACFCD must file a Report of Waste Discharge with the Regional Board no later than 140 days in advance of the 5th-year anniversary date of the Order for consideration of issuance of new or revised requirements. Any discharge of waste five years after the date of adoption of this Order, without filing a Report of Waste Discharge with this Regional Board, is a violation of Water Code section 13264. The Regional Board is authorized to take appropriate enforcement action for any noncompliance with this provision including assessment of penalties.





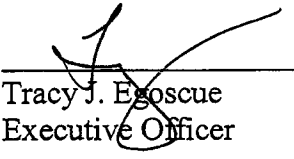



I, Tracy J. Egoscue, Executive Officer, do hereby certify the foregoing is a full, true and correct copy of an Order adopted by the California Regional Water Quality Control Board, Los Angeles Region, on February 4, 2010.

Ordered by:

  
\_\_\_\_\_  
Tracy J. Egoscue  
Executive Officer

**Attachment 2**

**Sample Copy  
Stream Channel Transect Shot**

	Transect Location	
	Tree Locations	
	Photo Station	
<b>Native Riparian Vegetation</b>		
	Willow Riparian Forest	1.35 Acres
	Southern Riparian Scrub	5.20 Acres
	<b>Total</b>	<b>6.55 Acres</b>
<b>Other Areas</b>		
	Open Water	0.60 Acres
	Non-native Grassland/Disturbed	31.44 Acres
	Sandy Wash	13.97 Acres
	Developed	2.54 Acres

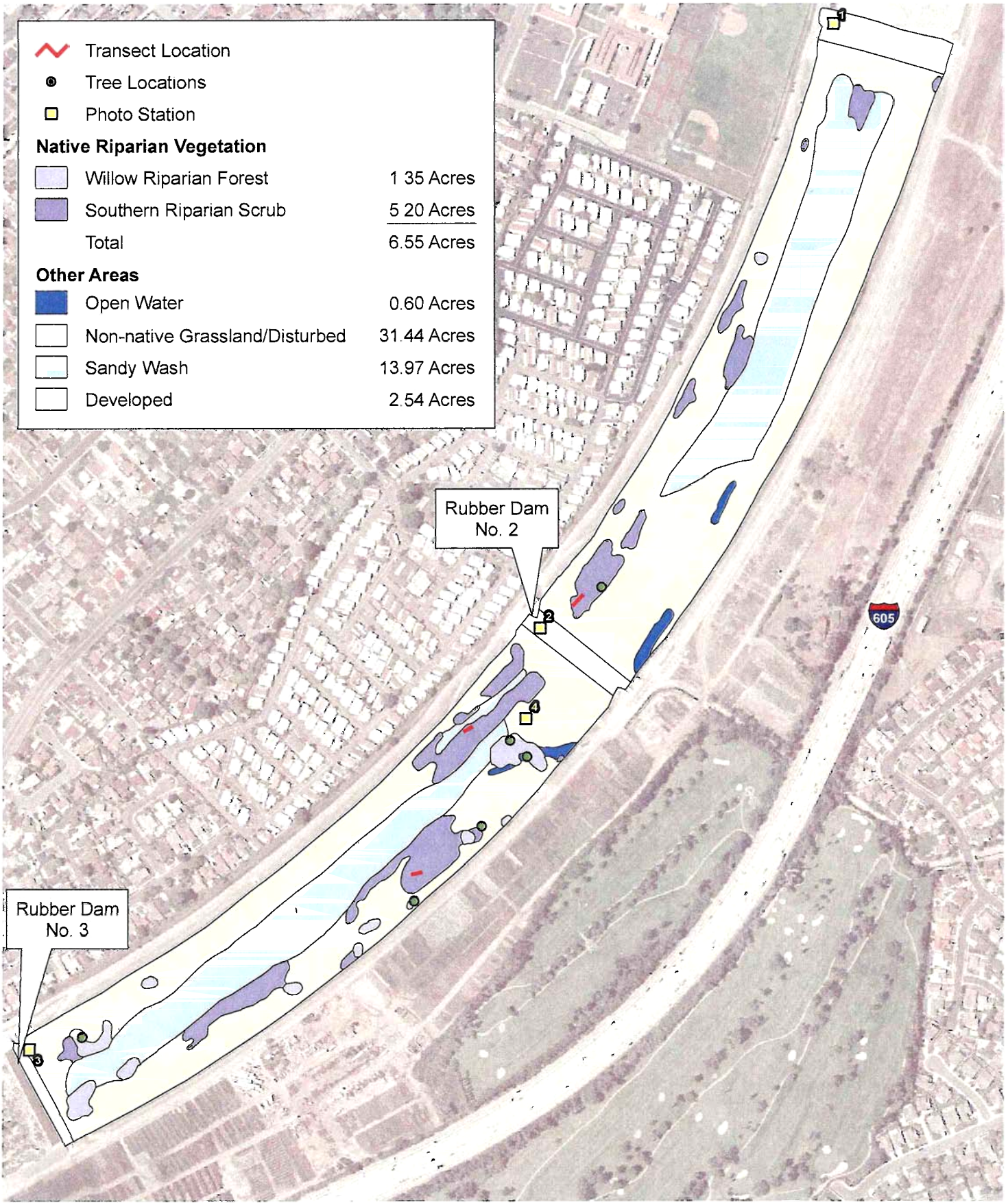

D:\Projects\ColADPW\J131\mxd\Ex\_veg\_2009.mxd

**Vegetation Conditions as of November, 2009** Exhibit 2

*Second Annual Vegetation Monitoring Report, San Gabriel River Rubber Dams No. 2 and No. 3*



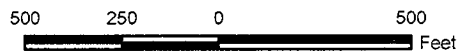

SAMPLE



(Rev 11/11/09 CJS) Projects/ColADPW/J131/Graphics/2AVRM/Ex2\_veg\_2009.pdf

**Attachment 3**

**Sample  
Completed Transect Data Collection Result**

SAMPLE

COMPARISON OF SPECIES COMPOSITION AND COVERAGE

Species	Size Class	Average % Cover		
		2004 (Baseline)	2008	2009
<b>Native Species</b>				
<i>Ambrosia acanthicarpa</i>	Seedling	—	—	0.3
<i>Artemisia californica</i>	Tree	2.7	—	—
<i>Artemisia douglasiana</i>	Tree	—	13.3	—
<i>Baccharis salicifolia</i>	Tree	—	11.7	4.3
<i>Heterotheca grandiflora</i>	Seedling	0.3	—	—
<i>Quercus agrifolia</i>	Seedling	—	—	0.3
<i>Salix exigua</i>	Tree	97.7	96.3	98.3
	Shrub	—	10.7	—
<i>Xanthium strumarium</i>	Shrub	0.7	0.3	1.7
<b>Non-Native Species</b>				
<i>Apium graveolens</i>	Seedling	0.3	—	—
<i>Arundo donax</i>	Tree	—	3.7	1.3
<i>Carduus pycnocephalus</i>	Seedling	1.7	—	—
<i>Conium maculatum</i>	Seedling	3.7	—	—
<i>Conyza canadensis</i>	Seedling	—	—	0.3
<i>Cyperus sp.</i>	Shrub	—	0.3	—
<i>Melilotus alba</i>	Seedling	—	—	0.3
Non-native grass	Seedling	66.3	—	—
Non-native herb	Seedling	0.3	—	—
<i>Picris echioides</i>	Seedling	6.3	—	—
<i>Polygonum arenastrum</i>	Shrub	—	8.7	—
<i>Raphanus sativus</i>	Seedling	0.7	—	—
<i>Ricinus communis</i>	Tree	—	—	0.7
	Shrub	0.3	—	—
	Seedling	2.3	—	—
<i>Rumex crispus</i>	Seedling	—	—	3.3
<i>Vinca major</i>	Seedling	—	—	3.0
<b>Total Native Cover by Size Class</b>				
<b>Native Tree Cover</b>		<b>97.7</b>	<b>99.7</b>	<b>98.3</b>
<b>Native Shrub Cover</b>		<b>0.0</b>	<b>20.0</b>	<b>1.7</b>
<b>Native Seedling Cover</b>		<b>1.0</b>	<b>0.0</b>	<b>0.7</b>
<b>Absolute Vegetative Cover</b>				
<b>NATIVE COVER</b>		<b>97.7</b>	<b>100</b>	<b>98.3</b>
<b>NON-NATIVE COVER</b>		<b>71.7</b>	<b>12.3</b>	<b>8.7</b>
<b>UNVEGETATED (NO PLANT)</b>		<b>1.0</b>	<b>0.0</b>	<b>1.7</b>



**VEGETATION TRANSECT DATA  
2009**

Species	Size Class	Percent Cover			Average % Cover
		Transect 2-1	Transect 3-1	Transect 3-2	
<b>Native Species</b>					
<i>Ambrosia acanthicarpa</i>	Seedling	1	—	—	0.3
<i>Baccharis salicifolia</i>	Tree	5	—	8	4.3
<i>Quercus agrifolia</i>	Seedling	1	—	—	0.3
<i>Salix exigua</i>	Tree	100	100	95	98.3
<i>Xanthium strumarium</i>	Shrub	—	5	—	1.7
<b>Non-Native Species</b>					
<i>Arundo donax</i>	Tree	—	4	—	1.3
<i>Coryza canadensis</i>	Seedling	—	—	1	0.3
<i>Melilotus alba</i>	Seedling	1	—	—	0.3
<i>Ricinus communis</i>	Tree	2	—	—	0.7
<i>Rumex crispus</i>	Seedling	10	—	—	3.3
<i>Vinca major</i>	Seedling	—	—	9	3.0
<b>Total Native Cover by Size Class</b>					
Native Tree Cover		100	100	95	98.3
Native Shrub Cover		0	5	0	1.7
Native Seedling Cover		2	0	0	0.7
<b>Absolute Vegetative Cover</b>					
NATIVE COVER		100	100	95	98.3
NON-NATIVE COVER		13	4	9	8.7
UNVEGETATED (NO PLANT)		0	0	5	1.7

**Attachment 4**

**Sample Form Used by Biologist  
During Transect Data Collection Survey**

PROJECT NAME:	JOB NO:
PROJECT SUB-AREA/HABITAT TYPE:	SURVEY YEAR:
FIELD STAFF:	SURVEY DATE:
TRANSECT (No./Length/Increment):	PAGE of

### Plant Species Cover

SPECIES	HITS	TOTAL HITS	% COVER

### Plant Class Cover

CLASS	HITS	TOTAL HITS	% COVER
Native			
Non-Native			
Both			
No Plant			

Total All Class Cover Hits: \_\_\_\_\_

### Ground Cover

COVER MATERIAL	HITS	TOTAL HITS	% COVER
Bare Soil			
Rock/Cobble			
Leaf Litter			
Coarse Woody Debris			
Other:			

Notes:

Total All Ground Cover Hits: \_\_\_\_\_  
Percent Cover Data Compiled by: \_\_\_\_\_  
Date Compiled: \_\_\_\_\_



**Attachment 5**

**Sample  
Water Quality Monitoring  
Field Data Sheet**

LOS ANGELES COUNTY DEPARTMENT OF PUBLIC WORKS  
 GEOTECHNICAL AND MATERIALS ENGINEERING DIVISION  
 2010 WATER QUALITY MONITORING FOR  
 SOFT BOTTOM CHANNEL CLEANOUTS

Channel/Reach. \_\_\_\_\_ PCA. \_\_\_\_\_

Date: \_\_\_\_\_

SAMPLE LOCATION	Upstream of Project*	Within Project*	Downstream of Project*
TIME <sup>#</sup>			
SAMPLE NO			
TEMPERATURE (°F)			
pH			
TURBIDITY (NTUs)			

- \* – Upstream of Project = 1, Within Project = 2, and Downstream of Project = 3 on sample labels and lab reports
- <sup>#</sup> – A = morning and P = afternoon on sample labels and lab reports
- Samples for Dissolved Oxygen and Total Suspended Solids are to be analyzed by one of GMED's As-Needed Contract Environmental Laboratories
- Field Equipment Used Hanna Model HI 991300 pH/EC/TDS/T Probe; LaMotte 2020e Turbidimeter

FIELD NOTES:

**Attachment 6**

**Sample  
Chain of Custody Form**



# American Environmental Testing Laboratory Inc.

2834 & 2908 North Naomi Street, Burbank, CA 91504 • DOHS NO: 1541, LACSD NO: 10181  
Tel: (888) 288-AETL • (818) 845-8200 • Fax: (818) 845-8840 • www.aetlab.com

## CHAIN OF CUSTODY RECORD

No 63875

COMPANY						PROJECT MANAGER		AETL JOB No. _____										Page ____ of ____				
COMPANY ADDRESS						PHONE		<b>ANALYSIS REQUESTED</b>										<b>TEST INSTRUCTIONS &amp; COMMENTS</b>				
						FAX																
PROJECT NAME						PROJECT #																
SITE NAME AND ADDRESS						PO #																
SAMPLE ID	LAB ID	DATE	TIME	MATRIX	CONTAINER NUMBER/SIZE	PRES.																
1																						
2																						
3																						
4																						
5																						
6																						
7																						
8																						
9																						
10																						
11																						
12																						
13																						
14																						
15																						
<b>SAMPLE RECEIPT - TO BE FILLED BY LABORATORY</b>						RELINQUISHED BY SAMPLER:		1.			RELINQUISHED BY:			2.			RELINQUISHED BY:			3.		
TOTAL NUMBER OF CONTAINERS		PROPERLY COOLED Y / N / NA				Signature:					Signature:						Signature:					
CUSTODY SEALS Y / N / NA		SAMPLES INTACT Y / N / NA				Printed Name:					Printed Name:						Printed Name:					
RECEIVED IN GOOD COND. Y / N		SAMPLES ACCEPTED Y / N				Date:		Time:			Date:			Time:			Date:			Time:		
<b>TURN AROUND TIME</b>						RECEIVED BY:		1.			RECEIVED BY:			2.			RECEIVED BY LABORATORY:			3.		
<input type="checkbox"/> NORMAL		<input type="checkbox"/> RUSH		<input type="checkbox"/> SAME DAY		<input type="checkbox"/> 2 DAYS		Signature:			Signature:			Signature:			Signature:					
		<input type="checkbox"/> NEXT DAY		<input type="checkbox"/> 3 DAYS		Printed Name:					Printed Name:						Printed Name:					
						Date:		Time:			Date:			Time:			Date:			Time:		

DISTRIBUTION: WHITE - Laboratory, CANARY - Laboratory, PINK - Project/Account Manager, YELLOW - Sampler/Originator



**Attachment 7**

**Sample Copy  
Completed WQ Monitoring  
Test and Lab Result**

LOS ANGELES COUNTY DEPARTMENT OF PUBLIC WORKS  
GEOTECHNICAL AND MATERIALS ENGINEERING DIVISION  
2009 WATER QUALITY MONITORING FOR  
SOFT BOTTOM CHANNEL CLEANOUTS

SAMPLE  
A

Channel/Reach: Kagel Canyon Channel

PCA: F1001263

Date: 09/29/09

Time#: 1115A

Time#: 1148A

Location\*: 1 (upstream)

Location\*: 2 (downstream)

Sample No.: KCC1A

Sample No.: KCC2A

Temperature (°F): 70.1

Temperature (°F): 75.0

pH: 7.49

pH: 7.26

Turbidity (NTUs): 6.17

Turbidity (NTUs): 0.91

Dissolved O<sub>2</sub> (mg/l): 8.69<sup>1</sup>

Dissolved O<sub>2</sub> (mg/l): 8.33<sup>1</sup>

TSS (mg/L): 27.0<sup>1</sup>

TSS (mg/L): ND<sup>1</sup>

- # A = a.m. or morning; P = p.m. or afternoon
- \*1 = Upstream on sample labels; 2 = Downstream on sample labels
- Dissolved Oxygen and Total Suspended Solids (TSS) are analyzed by GMED's As-Needed Contract Environmental Laboratory American Environmental Testing Labs (AETL); <sup>1</sup> – Reference: AETL Lab Report No. 54222; ND – not detected at or above the Method Detection Limit
- Field Equipment Used: HyDAC Conductivity, Temperature, pH Tester; LaMotte 2020 Turbidimeter

NOTES:

- Met with Crew Leader Manual Moncada from Hansen Yard on Tuesday, 9/29, to discuss cleanout operations, scope of project and number of days left to complete, water quality monitoring and potential upstream and downstream sampling points.
- Upstream Sampling Point (1) – in bottom of natural channel at concrete step; adjacent to the northwest corner of the single-family residence (SFR) at 11860 Creek Trail located along east side of Kagel Canyon Channel; see Figure 1 for location of upstream sampling point.
- Downstream Sampling Point (2) – located slightly over ¼-mile (about 1440 feet) southeast of upstream sampling point; on upstream side of Kagel Canyon Channel where it flows beneath Osborne Street/Little Tujunga Road; adjacent to California Polo Club at 11035 Osborne Street, Sylmar; see Figure 2 for location of downstream sampling point.

Sampling/monitoring requirements

- When water is required to be diverted, water sampling for soft-bottom channel cleanouts is required upstream and downstream daily before 4:00 p.m. for the first week and once a week thereafter.
- Flood Maintenance Division (FMD) needs monitoring for pH, temperature, dissolved oxygen, turbidity, and total suspended solids.
- All field sheets are due to Greg Johnson by the 8th of the month in order for FMD to meet their reporting requirements.

# LOS ANGELES COUNTY DEPARTMENT OF PUBLIC WORKS



NOTES:

Figure 1 Upstream Sampling Point (1) located in bottom of natural channel at  
 shallow concrete step, also located adjacent to the northwest corner of the  
 single-family residence (SFR) at 11860 Creek Trail adjacent to the east side of  
 Kagel Canyon Channel, slightly over 1/4-mile NW of sampling point 2 in Fig 2



LOS ANGELES COUNTY  
 DEPARTMENT OF PUBLIC WORKS  
 900 S. Fremont Ave  
 Alhambra, CA 91803

Kagel Cyn Channel Soft-Bottom Channel - WQ Monit  
 (Printed using View LA 09-Nov-09)



Data contained in this map is produced in whole or part from the Thomas Bros. Maps® digital database. This map is copyrighted, and reproduced with permission granted by Thomas Bros. Maps®. All rights reserved. Data contained in this map was produced in whole or part from the Los Angeles County Department of Public Works.

*SAMPLE*  
*H*

# LOS ANGELES COUNTY DEPARTMENT OF PUBLIC WORKS



NOTES:

Figure 2 Downstream Sampling Point (2) slightly over 1/4-mile southeast of  
 \_\_\_\_\_  
 of upstream sampling point, located on the upstream side of Kagel Canyon Channel  
 \_\_\_\_\_  
 where is flows beneath Osborne Street/Little Tujunga Road  
 \_\_\_\_\_  
 \_\_\_\_\_

	<p>LOS ANGELES COUNTY          DEPARTMENT OF PUBLIC WORKS          900 S. Fremont Ave.          Alhambra, CA 91803</p>	<p>Kagel Cyn Channel Soft-Bottom Cleanout - WQ Monit.          (Printed using View LA 09-Nov-09)</p>	<p>N  </p>
<p><small>Data contained in this map is produced in whole or part from the Thomas Bros Maps® digital database. This map is copyrighted, and reproduced with permission granted by Thomas Bros Maps®. All rights reserved.</small></p>		<p><small>Data contained in this map was produced in whole or part from the Los Angeles County Department of Public Works</small></p>	

*SAMPLE*



## American Environmental Testing Laboratory Inc.

2834 & 2908 North Naomi Street Burbank, CA 91504 • DOHS NO: 1541, LACSD NO: 10181  
Tel: (888) 288-AETL • (818) 845-8200 • Fax: (818) 845-8840 • www.aetlab.com

### Ordered By

LA County Dept. of Public Works  
GMED Materials Lab 900 S. Fremont Ave,  
4th Floor  
Alhambra, CA 91803-

Telephone: (626) 458-5100  
Attention: Greg Johnson

Number of Pages 4  
Date Received 09/30/2009  
Date Reported 10/07/2009

Job Number	Order Date	Client
54222	09/30/2009	LACDPW

Project ID: F1001263  
Project Name: Soft Bottom Channel Cleanouts  
Site: Kagel Canyon Channel  
Caballero Creek Channel  
San Jose Creek

Enclosed please find results of analyses of 5 water samples which were analyzed as specified on the attached chain of custody. If there are any questions, please do not hesitate to call.

SAMPLES  
A

Checked By: \_\_\_\_\_

Approved By: \_\_\_\_\_

C. Razmara

Cyrus Razmara, Ph D  
Laboratory Director



# American Environmental Testing Laboratory Inc.

2834 & 2908 North Naomi Street, Burbank, CA 91504 • DOHS NO: 1541, LACSD NO: 10181  
Tel: (888) 288-AETL • (818) 845-8200 • Fax: (818) 845-8840 • www.aetlab.com

# CHAIN OF CUSTODY RECORD

No 64032

Page 1 of 1

COMPANY **LACEDAW 61420 MATERIALS LAB** PROJECT MANAGER **Greg Johnson**  
 COMPANY ADDRESS **900 S. FLEMONT AVE, 4TH FLR ALHAMBRA 91803** PHONE **626 458-1741**  
 PROJECT NAME **SOFT BOTTOM CHANNEL CLEANOUTS - DQ ANALYSES** PROJECT # **F1001263** FAX **323/221-6501**  
 SITE NAME AND ADDRESS **VARIOUS** PO # **11C00000395**

AETL JOB No. **54222**

SAMPLE ID	LAB ID	DATE	TIME	MATRIX	CONTAINER NUMBER/SIZE	PRES.
KCC1A	54222.01	9/26/09	1115	WATER	1-500ML	N/A
KCC2A	54222.02	"	1148	"	"	"
CCC2P	54222.03	"	1441	"	"	"
STCRK1P	54222.04	9/30/09	1207	"	"	"
STCRK2P	54222.05	"	1222	"	"	"

ANALYSIS REQUESTED										TEST INSTRUCTIONS & COMMENTS
										TOTAL #SUSPENDED SOLIDS DISSOLVED OR
										KCC = KANEL CANYON CHANNEL
										CCC = CARROLLWOOD CREEK CHANNEL
										STCRK = SAN JOSE CREEK
										1 = UPSTREAM 2 = DOWNSTREAM A = MORNING P = AFTERNOON

**SAMPLE RECEIPT - TO BE FILLED BY LABORATORY**

TOTAL NUMBER OF CONTAINERS: **5** PROPERLY COOLED Y/N/NA  
 CUSTODY SEALS Y/N/NA: **Y/N** SAMPLES INTACT Y/N/NA  
 RECEIVED IN GOOD COND. Y/N: **Y/N** SAMPLES ACCEPTED Y/N

TURN AROUND TIME  
 NORMAL  RUSH  SAME DAY  2 DAYS  
 NEXT DAY  3 DAYS

RELINQUISHED BY SAMPLER: **1.** Signature: **[Signature]** Printed Name: **Greg K. Johnson** Date: **9/30/09** Time: **1550**

RELINQUISHED BY: **2.** Signature: **[Signature]** Printed Name: **[Signature]** Date: **[Date]** Time: **[Time]**

RECEIVED BY: **1.** Signature: **[Signature]** Printed Name: **[Signature]** Date: **[Date]** Time: **[Time]**

RECEIVED BY LABORATORY: **3.** Signature: **[Signature]** Printed Name: **Jean Claude** Date: **09/30/09** Time: **1550**



# American Environmental Testing Laboratory Inc.

2834 & 2908 North Naomi Street Burbank, CA 91504 • DOHS NO: 1541, LACSD NO: 10181  
 Tel: (888) 288-AETL • (818) 845-8200 • Fax: (818) 845-8840 • www.aetlab.com

## ANALYTICAL RESULTS

### Ordered By

LA County Dept. of Public Works  
 GMED Materials Lab  
 900 S. Fremont Ave, 4th Floor  
 Alhambra, CA 91803-

### Site

Kagel Canyon Channel  
 Caballero Creek Channel  
 San Jose Creek

Telephone: (626) 458-5100

Attn: Greg Johnson

Page 2

Project ID: F1001263

Project Name: Soft Bottom Channel Cleanouts

AETL Job Number	Submitted	Client
54222	09/30/2009	LACDPW

Analytes	Oxygen, Dissolved	Total Suspended Solids (TSS)	
Methods of Analyses	SM-4500-OG	SM-2540-D	
Date Prepared	09/30/2009	10/01/2009	
Date Analyzed	09/30/2009	10/01/2009	
Matrix	Aqueous	Aqueous	
QC Batch Number	093009	100109	
Units	mg/L	mg/L	
Method Detection Limit	0.10	0.50	
Practical Quantitation Limit	0.10	5.00	
Dilution Factor	1	1	
Lab ID	Sample ID	Sampled	Results
54222.01	KCC1A	09/29/2009	8.69
54222.02	KCC2A	09/29/2009	8.33
54222.03	CCC2P	09/29/2009	8.94
54222.04	SJCRK1P	09/29/2009	8.45
54222.05	SJCRK2P	09/29/2009	7.10
N/A	Method Blank	09/29/2009	NA



# American Environmental Testing Laboratory Inc.

2834 & 2908 North Naomi Street Burbank, CA 91504 • DOHS NO: 1541, LACSD NO: 10181  
 Tel: (888) 288-AETL • (818) 845-8200 • Fax: (818) 845-8840 • www.aetlab.com

## QUALITY CONTROL RESULTS

### Ordered By

LA County Dept. of Public Works  
 GMED Materials Lab  
 900 S. Fremont Ave, 4th Floor  
 Alhambra, CA 91803-

Telephone: (626)458-5100

Attn. Greg Johnson

Page. **3**

Project ID: F1001263

Project Name: Soft Bottom Channel Cleanouts

### Site

Kagel Canyon Channel  
 Caballero Creek Channel  
 San Jose Creek

AETL Job Number	Submitted	Client
54222	09/30/2009	LACDPW

Method SM-2540-D, Residue, Non-Filterable, Gravimetric Dried at 103-105C

QC Batch No: 100109; Dup or Spiked Sample: 54220.01; LCS: Clean Water; LCS Prepared: 10/01/2009; LCS Analyzed: 10/01/2009;

Units: mg/L

Analytes	SM	SM DUP	RPD	SM RPD	LCS	LCS	LCS	LCS/LCSD		
	Result	Result	%	% Limit	Concen	Recov	% REC	% Limit		
Total Suspended Solids (TSS)	7700	7600	1.3	<15	100	97.0	97.0	80-120		





# American Environmental Testing Laboratory Inc.

2834 & 2908 North Naomi Street Burbank, CA 91504 • DOHS NO: 1541, LACSD NO: 10181  
Tel: (888) 288-AETL • (818) 845-8200 • Fax: (818) 845-8840 • www.aetlab.com

## QUALITY CONTROL RESULTS

### Ordered By

LA County Dept. of Public Works  
GMED Materials Lab  
900 S. Fremont Ave, 4th Floor  
Alhambra, CA 91803-

Telephone: (626)458-5100

Attn Greg Johnson

Page: 4

Project ID: F1001263

Project Name: Soft Bottom Channel Cleanouts

### Site

Kagel Canyon Channel  
Caballero Creek Channel  
San Jose Creek

AETL Job Number	Submitted	Client
54222	09/30/2009	LACDPW

Method: SM-4500-OG, Total Dissolved Oxygen (Std. Methods, 19th ed.)

QC Batch No: 093009; Dup or Spiked Sample: 54220.01, Units: mg/L

Analytes	SM Result	SM DUP Result	RPD %	SM RPD % Limit						
Oxygen, Dissolved	5.78	5.71	1.2	<15						



## American Environmental Testing Laboratory Inc.

2834 & 2908 North Naomi Street, Burbank, CA 91504 • DOHS NO: 1541, LACSD NO: 10181  
Tel: (888) 288-AETL • (818) 845-8200 • Fax: (818) 845-8840 • www.aetlab.com

### Data Qualifiers and Descriptors

#### ***Data Qualifier:***

- \*: In the QC section, sample results have been taken directly from the ICP reading. No preparation factor has been applied.
- B: Analyte was present in the Method Blank.
- D: Result is from a diluted analysis.
- E: Result is beyond calibration limits and is estimated.
- H: Analysis was performed over the allowed holding time due to circumstances which were beyond laboratory control.
- J: Analyte was detected. However, the analyte concentration is an estimated value, which is between the Method Detection Limit (MDL) and the Practical Quantitation Limit (PQL).
- M: Matrix spike recovery is outside control limits due to matrix interference. Laboratory Control Sample recovery was acceptable.
- MCL: Maximum Contaminant Level
- NS: No Standard Available
- S6: Surrogate recovery is outside control limits due to matrix interference.
- S8: The analysis of the sample required a dilution such that the surrogate concentration was diluted below the method acceptance criteria.
- X: Results represent LCS and LCSD data.

#### ***Definition:***

- %Limi: Percent acceptable limits.
- %REC: Percent recovery
- Con.L: Acceptable Control Limits
- Conce: Added concentration to the sample.
- LCS: Laboratory Control Sample
- MDL: Method Detection Limit is a statistically derived number which is specific for each instrument, each method, and each compound. It indicates a distinctively detectable quantity with 99% probability.



## American Environmental Testing Laboratory Inc.

2834 & 2908 North Naomi Street, Burbank, CA 91504 • DOHS NO: 1541, LACSD NO: 10181  
Tel: (888) 288-AETL • (818) 845-8200 • Fax: (818) 845-8840 • www.aetlab.com

### Data Qualifiers and Descriptors

MS:	Matrix Spike
MS DU:	Matrix Spike Duplicate
ND:	Analyte was not detected in the sample at or above MDL.
PQL:	Practical Quantitation Limit or ML (Minimum Level as per RWQCB) is the minimum concentration that can be quantified with more than 99% confidence. Taking into account all aspects of the entire analytical instrumentation and practice.
Recov:	Recovered concentration in the sample.
RPD:	Relative Percent Difference

---

**Attachment 8**

**Best Management Practices Manual  
Soft-Bottom Channel Clearing**

**BMP MANUAL  
FOR  
SOFT BOTTOM CLEARING**

August 2003

## **TABLE OF CONTENTS**

- EC-1 Scheduling
- EC-2 Preservation of Existing Vegetation
- NS-4 Temporary Stream Crossing
- NS-8 Vehicles and Equipment Cleaning
- NS-10 Vehicles and Equipment Maintenance
- SC-11 Spill Prevention, Control and Cleanup
- SC-60 Housekeeping Practices
- SE-1 Silt Fence
- SE-8 Sandbag Barrier
- SE-9 Straw Bale Barrier
- WE-1 Wind Erosion Control
- WM-5 Solid Waste Management
- WM-6 Hazardous Waste Management
- WM-7 Contaminated Soil Management
  
- Additional Soft Bottom Channel BMP clarification and explanation

Best Management Practices as it pertains to Soft Bottom Channel Clearing is defined as any procedure or policy that would help reduce pollutants in the channel.

The following is the list of BMP's from the new California Storm Water Best Management Practices Handbook, January 2003 edition that Flood Maintenance will use on Soft Bottom Channel Clearing. Attached is a hard copy of each of the BMP's on that list. If for any reason during the course of Soft Bottom Channel Clearing additional procedures are needed, the staff is encouraged to refer the aforementioned Handbook.

<u>New BMP</u>	<u>New Manual</u>	<u>Old BMP (1993)</u>
1. EC-1 Scheduling	Construction Manual	ESC-1
2. EC-2 Preservation of Existing Vegetation	Construction Manual	ESC-2
3. NS-4 Temporary Stream Crossing	Construction Manual	ESC-22
4. SE-1 Silt Fence	Construction Manual	ESC-50
5. SE-9 Straw Bale Barrier	Construction Manual	ESC-51
6. SE-8 Sandbag Barrier	Construction Manual	ESC-52

The following is a list of BMP's that were used by Flood Maintenance Division on past Soft Bottom Channel Cleaning but was not listed in our Manual:

7. SC-11 Spill Prevention, Control & Cleanup	Municipal Manual
8. WM-5 Solid Waste Management	Construction Manual
9. WM-6 Hazardous Waste Management	Construction Manual
10. NS-8 Vehicles and Equipment Cleaning	Construction Manual
11. NS-10 Vehicles & Equipment Maintenance	Construction Manual
12. WM-7 Contaminated Soil Management	Construction Manual
13. SC-60 Housekeeping Practices	Municipal Manual
14. WE-1 Wind Erosion Control	Construction Manual

## **GUIDELINES ON THE USE OF SOFT BOTTOM CHANNEL CLEARING BMPs**

Additionally, here are some clarifications and detailed explanations of BMP's to be used throughout the Division during Soft Bottom Channel Clearing:

- Drip pans are used to contain any leaky vehicle or equipment. BMP NS-10 is to be followed at all times.
- Designated field crews will be available at all times to contain any spill in or outside the channels. Licensed vendors are called to do the clean up. Check BMP SC-11 Spill Prevention, Control and Cleaning.
- Water spraying during soft bottom channel clearing is the only acceptable means to control dust. Check BMP WE-1 Wind Erosion Control.
- Chemical usage will not be permitted during the course of the soft bottom channel clearing.
- Vehicles and equipment are taken to wash racks with clarifier for cleaning. Vehicle and equipment cleaning BMP NS-8 is to be followed at all times.
- Chemicals or detergents generated or used by our Division are to be stored in a secure place, to be picked up every 90 days by a licensed vendor for disposal. In the case of a spill, our field crews will contain it and call a licensed vendor for clean up and disposal. Check BMP WM-6 Hazardous Waste Management.
- Vehicles and Equipment refueling will be done outside the channel bottom (i.e. on access roads). The soft bottom of the channel is the flood plain of that channel and any refueling activities and maintenance should be carried outside that limit. Check BMP NS-10 Vehicles and Equipment Maintenance.
- During the soft bottom channel clearing trash/debris is hauled away from the channel to be stored in a bin and later taken to a legal dump site. Check BMP WM-5 Solid Waste Management.
- Side Casting will be defined as the piling of debris and soil to the side of the soft bottom channel. This is not permissible in the soft bottom clearing due to the fact that it amounts to regrading the bottom of the channel. The soil and sediments from previous storms could be groomed or leveled in a way to allow the natural flow of water and minimize stormwater pollution.

For additional BMP's use the California Storm Water Best Management Practices Handbook, 2003 edition at [www.cabmphandbooks.com](http://www.cabmphandbooks.com). Other good housekeeping BMP practices can be found at [www.bmpla.org](http://www.bmpla.org).



# Scheduling

EC-1

JANUARY				
MONDAY	TUESDAY	WEDNESDAY	THURSDAY	FRIDAY
		1	2 NTP MOBILIZATION	3
			8 Land clearing	10 Grading
6 Install erosion & sediment control measures	7		9	15
		13	14	15
				22
				23

## Description and Purpose

Scheduling is the development of a written plan that includes sequencing of construction activities and the implementation of BMPs such as erosion control and sediment control while taking local climate (rainfall, wind, etc.) into consideration. The purpose is to reduce the amount and duration of soil exposed to erosion by wind, rain, runoff, and vehicle tracking, and to perform the construction activities and control practices in accordance with the planned schedule.

## Suitable Applications

Proper sequencing of construction activities to reduce erosion potential should be incorporated into the schedule of every construction project especially during rainy season. Use of other, more costly yet less effective, erosion and sediment control BMPs may often be reduced through proper construction sequencing.

## Limitations

- Environmental constraints such as nesting season prohibitions reduce the full capabilities of this BMP.

## Implementation

- Avoid rainy periods. Schedule major grading operations during dry months when practical. Allow enough time before rainfall begins to stabilize the soil with vegetation or physical means or to install sediment trapping devices.
- Plan the project and develop a schedule showing each phase of construction. Clearly show how the rainy season relates to soil

## Objectives

EC	Erosion Control	✓
SE	Sediment Control	✓
TC	Tracking Control	✓
WE	Wind Erosion Control	✓
NS	Non-Stormwater Management Control	
WM	Waste Management and Materials Pollution Control	

## Legend:

- ✓ Primary Objective
- ✓ Secondary Objective

## Targeted Constituents

Sediment	✓
Nutrients	
Trash	
Metals	
Bacteria	
Oil and Grease	
Organics	

## Potential Alternatives

None



disturbing and re-stabilization activities. Incorporate the construction schedule into the SWPPP.

- Include on the schedule, details on the rainy season implementation and deployment of:
  - Erosion control BMPs
  - Sediment control BMPs
  - Tracking control BMPs
  - Wind erosion control BMPs
  - Non-stormwater BMPs
  - Waste management and materials pollution control BMPs
- Include dates for activities that may require non-stormwater discharges such as dewatering, sawcutting, grinding, drilling, boring, crushing, blasting, painting, hydro-demolition, mortar mixing, pavement cleaning, etc.
- Work out the sequencing and timetable for the start and completion of each item such as site clearing and grubbing, grading, excavation, paving, foundation pouring utilities installation, etc., to minimize the active construction area during the rainy season.
  - Sequence trenching activities so that most open portions are closed before new trenching begins.
  - Incorporate staged seeding and re-vegetation of graded slopes as work progresses.
  - Schedule establishment of permanent vegetation during appropriate planting time for specified vegetation.
- Non-active areas should be stabilized as soon as practical after the cessation of soil disturbing activities or one day prior to the onset of precipitation.
- Monitor the weather forecast for rainfall.
- When rainfall is predicted, adjust the construction schedule to allow the implementation of soil stabilization and sediment treatment controls on all disturbed areas prior to the onset of rain.
- Be prepared year round to deploy erosion control and sediment control BMPs. Erosion may be caused during dry seasons by un-seasonal rainfall, wind, and vehicle tracking. Keep the site stabilized year round, and retain and maintain rainy season sediment trapping devices in operational condition.
- Apply permanent erosion control to areas deemed substantially complete during the project's defined seeding window.

### **Costs**

Construction scheduling to reduce erosion may increase other construction costs due to reduced economies of scale in performing site grading. The cost effectiveness of scheduling techniques should be compared with the other less effective erosion and sedimentation controls to achieve a cost effective balance.

## Inspection and Maintenance

- Verify that work is progressing in accordance with the schedule. If progress deviates, take corrective actions.
- Amend the schedule when changes are warranted.
- Amend the schedule prior to the rainy season to show updated information on the deployment and implementation of construction site BMPs.

## References

Stormwater Quality Handbooks Construction Site Best Management Practices (BMPs) Manual, State of California Department of Transportation (Caltrans), November 2000.

Stormwater Management for Construction Activities Developing Pollution Prevention Plans and Best Management Practices (EPA 832-R-92-005), U.S. Environmental Protection Agency, Office of Water, September 1992.

# Preservation Of Existing Vegetation EC-2

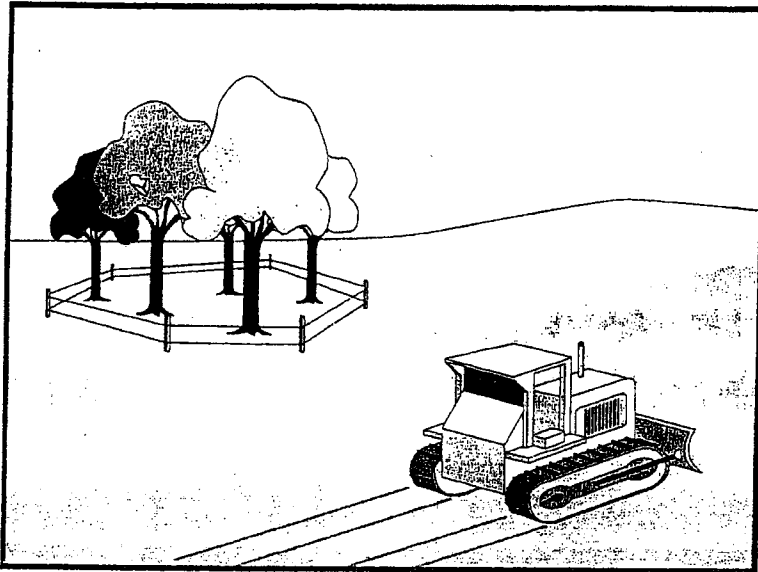

## Description and Purpose

Carefully planned preservation of existing vegetation minimizes the potential of removing or injuring existing trees, vines, shrubs, and grasses that protect soil from erosion.

## Suitable Applications

Preservation of existing vegetation is suitable for use on most projects. Large project sites often provide the greatest opportunity for use of this BMP. Suitable applications include the following:

- Areas within the site where no construction activity occurs, — or occurs at a later date. This BMP is especially suitable to multi year projects where grading can be phased.
- Areas where natural vegetation exists and is designated for preservation. Such areas often include steep slopes, watercourse, and building sites in wooded areas.
- Areas where local, state, and federal government require preservation, such as vernal pools, wetlands, marshes, certain oak trees, etc. These areas are usually designated on the plans, or in the specifications, permits, or environmental documents.
- Where vegetation designated for ultimate removal can be temporarily preserved and be utilized for erosion control and sediment control.

## Objectives

EC	Erosion Control	✓
SE	Sediment Control	
TC	Tracking Control	
WE	Wind Erosion Control	
NS	Non-Stormwater Management Control	
WM	Waste Management and Materials Pollution Control	

## Legend:

- ✓ Primary Objective
- ✓ Secondary Objective

## Targeted Constituents

Sediment	✓
Nutrients	
Trash	
Metals	
Bacteria	
Oil and Grease	
Organics	

## Potential Alternatives

None



# **EC-2 Preservation Of Existing Vegetation**

## **Limitations**

- Requires forward planning by the owner/developer, contractor, and design staff.
- Limited opportunities for use when project plans do not incorporate existing vegetation into the site design.
- For sites with diverse topography, it is often difficult and expensive to save existing trees while grading the site satisfactory for the planned development.

## **Implementation**

The best way to prevent erosion is to not disturb the land. In order to reduce the impacts of new development and redevelopment, projects may be designed to avoid disturbing land in sensitive areas of the site (e.g., natural watercourses, steep slopes), and to incorporate unique or desirable existing vegetation into the site's landscaping plan. Clearly marking and leaving a buffer area around these unique areas during construction will help to preserve these areas as well as take advantage of natural erosion prevention and sediment trapping.

Existing vegetation to be preserved on the site must be protected from mechanical and other injury while the land is being developed. The purpose of protecting existing vegetation is to ensure the survival of desirable vegetation for shade, beautification, and erosion control. Mature vegetation has extensive root systems that help to hold soil in place, thus reducing erosion. In addition, vegetation helps keep soil from drying rapidly and becoming susceptible to erosion. To effectively save existing vegetation, no disturbances of any kind should be allowed within a defined area around the vegetation. For trees, no construction activity should occur within the drip line of the tree.

## **Timing**

- Provide for preservation of existing vegetation prior to the commencement of clearing and grubbing operations or other soil disturbing activities in areas where no construction activity is planned or will occur at a later date.

## **Design and Layout**

- Mark areas to be preserved with temporary fencing. Include sufficient setback to protect roots.
  - Orange colored plastic mesh fencing works well.
  - Use appropriate fence posts and adequate post spacing and depth to completely support the fence in an upright position.
- Locate temporary roadways, stockpiles, and layout areas to avoid stands of trees, shrubs, and grass.
- Consider the impact of grade changes to existing vegetation and the root zone.
- Maintain existing irrigation systems where feasible. Temporary irrigation may be required.
- Instruct employees and subcontractors to honor protective devices. Prohibit heavy equipment, vehicular traffic, or storage of construction materials within the protected area.

# **Preservation Of Existing Vegetation EC-2**

## **Costs**

There is little cost associated with preserving existing vegetation if properly planned during the project design, and these costs may be offset by aesthetic benefits that enhance property values. During construction, the cost for preserving existing vegetation will likely be less than the cost of applying erosion and sediment controls to the disturbed area. Replacing vegetation inadvertently destroyed during construction can be extremely expensive, sometimes in excess of \$10,000 per tree.

## **Inspection and Maintenance**

During construction, the limits of disturbance should remain clearly marked at all times. Irrigation or maintenance of existing vegetation should be described in the landscaping plan. If damage to protected trees still occurs, maintenance guidelines described below should be followed:

- Verify that protective measures remain in place. Restore damaged protection measures immediately.
- Serious tree injuries shall be attended to by an arborist.
- Damage to the crown, trunk, or root system of a retained tree shall be repaired immediately.
- Trench as far from tree trunks as possible, usually outside of the tree drip line or canopy. Curve trenches around trees to avoid large roots or root concentrations. If roots are encountered, consider tunneling under them. When trenching or tunneling near or under trees to be retained, place tunnels at least 18 in. below the ground surface, and not below the tree center to minimize impact on the roots.
- Do not leave tree roots exposed to air. Cover exposed roots with soil as soon as possible. If soil covering is not practical, protect exposed roots with wet burlap or peat moss until the tunnel or trench is ready for backfill.
- Cleanly remove the ends of damaged roots with a smooth cut.
- Fill trenches and tunnels as soon as possible. Careful filling and tamping will eliminate air spaces in the soil, which can damage roots.
- If bark damage occurs, cut back all loosened bark into the undamaged area, with the cut tapered at the top and bottom and drainage provided at the base of the wood. Limit cutting the undamaged area as much as possible.
- Aerate soil that has been compacted over a trees root zone by punching holes 12 in. deep with an iron bar, and moving the bar back and forth until the soil is loosened. Place holes 18 in. apart throughout the area of compacted soil under the tree crown.
- Fertilization
  - Fertilize stressed or damaged broadleaf trees to aid recovery.
  - Fertilize trees in the late fall or early spring.

## **EC-2 Preservation Of Existing Vegetation**

- Apply fertilizer to the soil over the feeder roots and in accordance with label instructions, but never closer than 3 ft to the trunk. Increase the fertilized area by one-fourth of the crown area for conifers that have extended root systems.
- Retain protective measures until all other construction activity is complete to avoid damage during site cleanup and stabilization.

### **References**

County of Sacramento Tree Preservation Ordinance, September 1981.

Stormwater Quality Handbooks Construction Site Best Management Practices (BMPs) Manual, State of California Department of Transportation (Caltrans), November 2000.

Stormwater Management of the Puget Sound Basin, Technical Manual, Publication #91-75, Washington State Department of Ecology, February 1992.

Water Quality Management Plan for The Lake Tahoe Region, Volume II, Handbook of Management Practices, Tahoe Regional Planning Agency, November 1988.

- Disturbance or removal of vegetation should not exceed the minimum necessary to complete operations. Precautions should be taken to avoid damage to vegetation by people or equipment. Disturbed vegetation should be replaced with the appropriate soil stabilization measures.
- Riparian vegetation, when removed pursuant to the provisions of the work, should be cut off no lower than ground level to promote rapid re-growth. Access roads and work areas built over riparian vegetation should be covered by a sufficient layer of clean river run cobble to prevent damage to the underlying soil and root structure. The cobble must be removed upon completion of project activities.
- Conceptual temporary stream crossings are shown in the attached figures.

## Costs

Caltrans Construction Cost index for temporary bridge crossings is \$45-\$95/ft<sup>2</sup>.

## Inspection and Maintenance

- Inspect and verify that activity-based BMPs are in place prior to the commencement of associated activities. While activities associated with the BMP are under way, inspect weekly during the rainy season and at two week intervals in the non-rainy season to verify continued BMP implementation.
- Check for blockage in the channel, sediment buildup or trapped debris in culverts, blockage behind fords or under bridges
- Check for erosion of abutments, channel scour, riprap displacement, or piping in the soil
- Check for structural weakening of the temporary crossings, such as cracks, and undermining of foundations and abutments
- Remove sediment that collects behind fords, in culverts, and under bridges periodically
- Replace lost or displaced aggregate from inlets and outlets of culverts and cellular confinement systems
- Remove temporary crossing promptly when it is no longer needed

## References

California Bank and Shore Rock Slope Protection Design – Practitioners Guide and Field Evaluations of Riprap Methods, Caltrans Study No. F90TLo3, October 2000.

Stormwater Quality Handbooks - Construction Site Best Management Practices (BMPs) Manual, State of California Department of Transportation (Caltrans), November 2000.



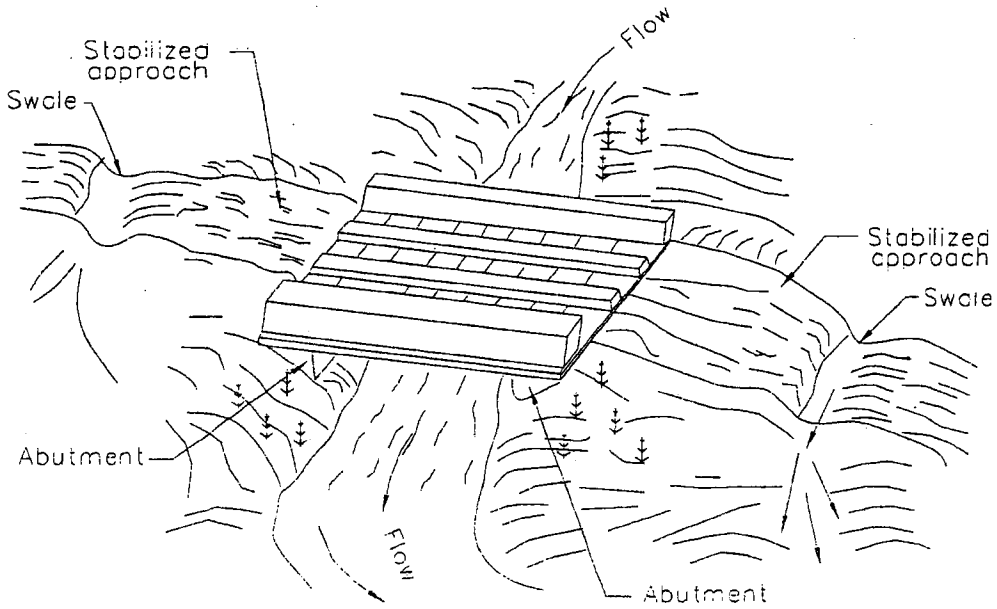

NOTE:  
Surface flow of road diverted  
by swale and/or dike.

TYPICAL BRIDGE CROSSING  
NOT TO SCALE

# Temporary Stream Crossing

NS-4

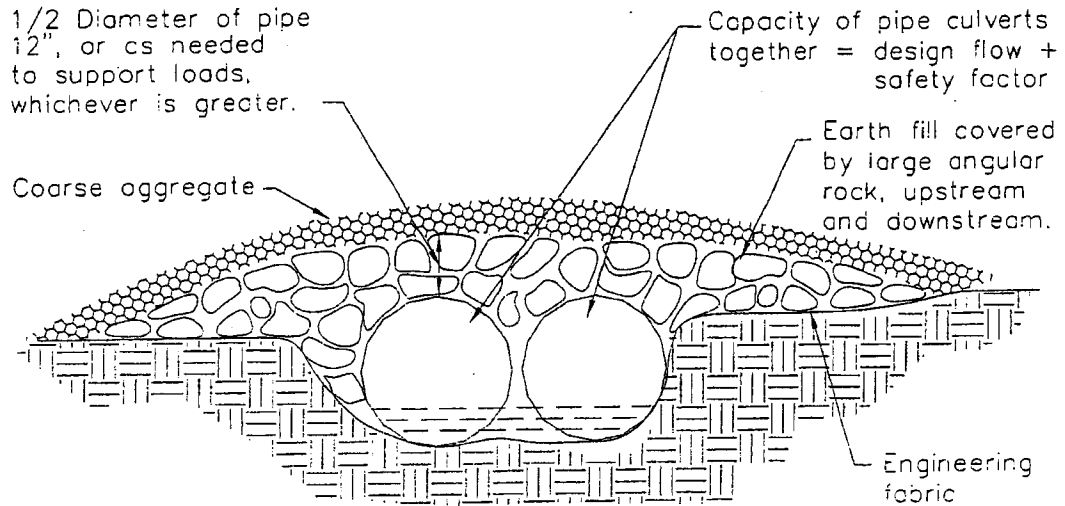

## ELEVATION

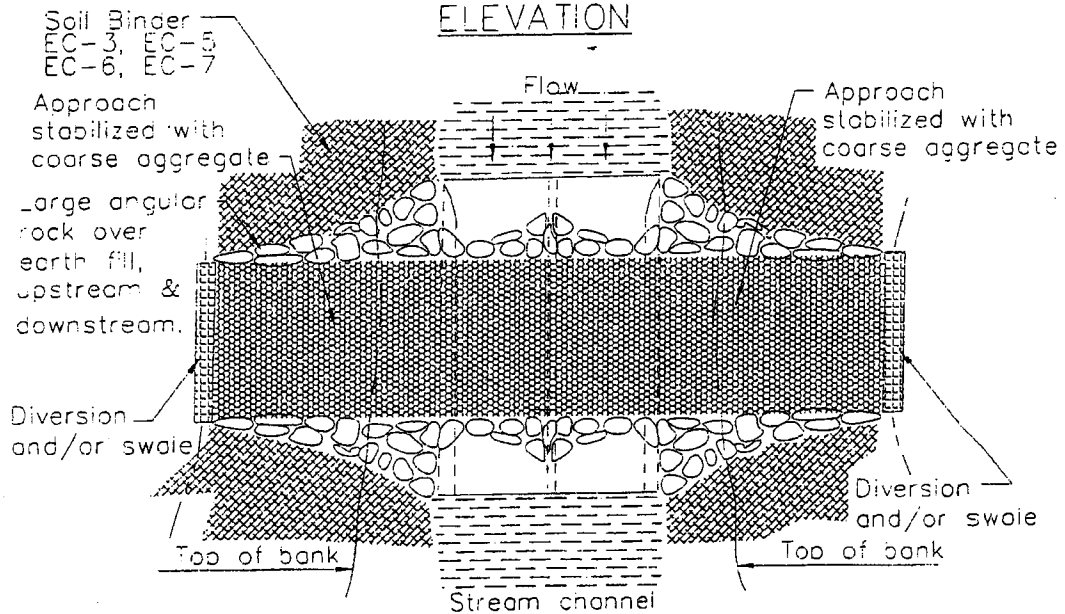

## PLAN VIEW

TYPICAL CULVERT CROSSING  
NOT TO SCALE

# NS-4

# Temporary Stream Crossing

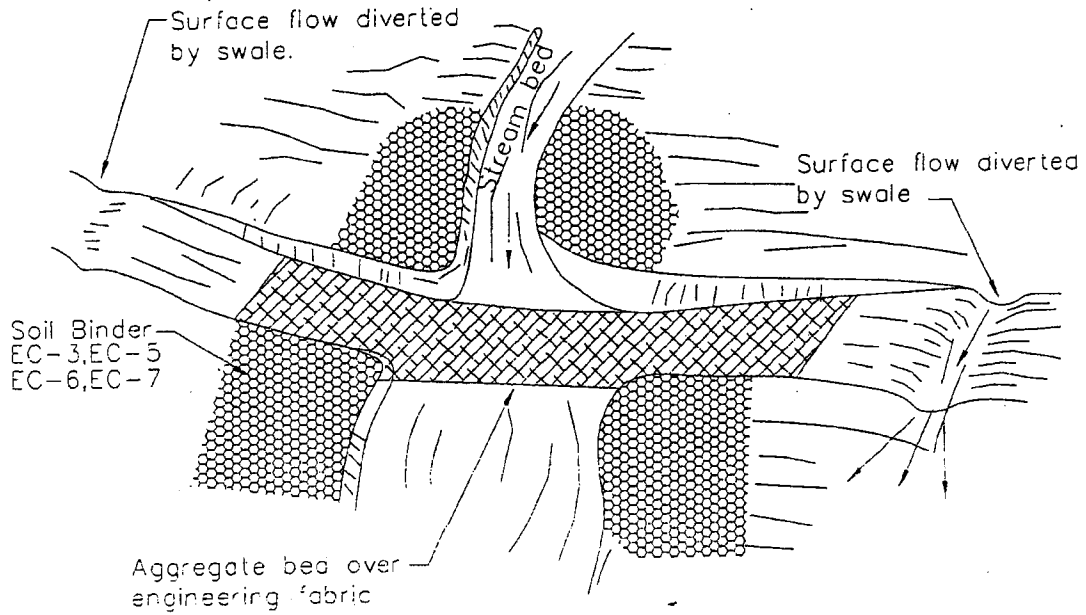

Aggregate approach  
1:5 (V:H) Maximum slope on road

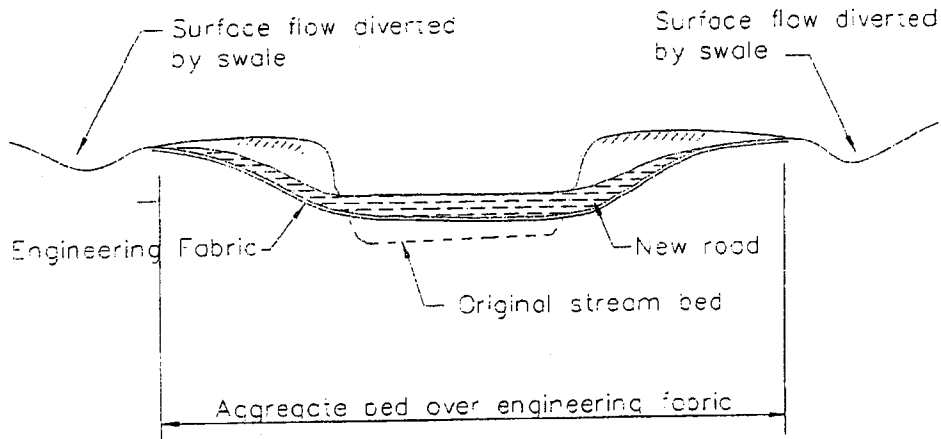

TYPICAL FORD CROSSING  
NOT TO SCALE

# Vehicle & Equipment Maintenance NS-10

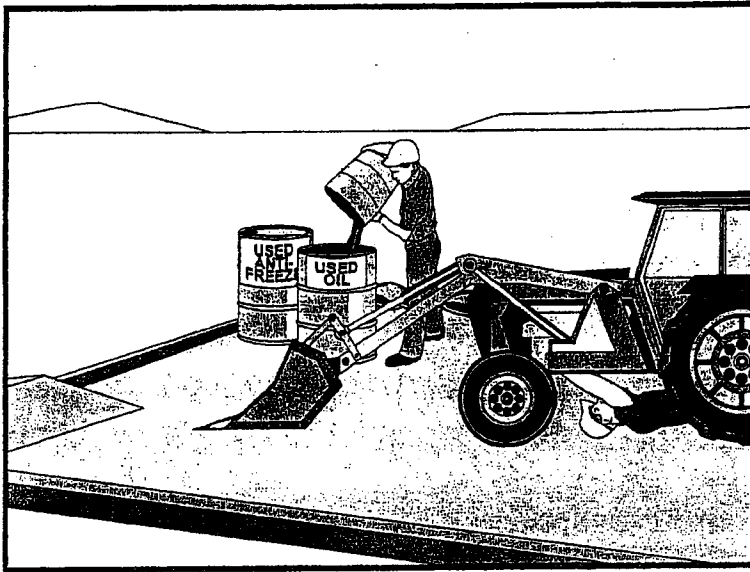

## Description and Purpose

Prevent or reduce the contamination of stormwater resulting from vehicle and equipment maintenance by running a “dry and clean site”. The best option would be to perform maintenance activities at an offsite facility. If this option is not available then work should be performed in designated areas only, while providing cover for materials stored outside, checking for leaks and spills, and containing and cleaning up spills immediately. Employees and subcontractors must be trained in proper procedures.

## Suitable Applications

These procedures are suitable on all construction projects where an onsite yard area is necessary for storage and maintenance of heavy equipment and vehicles.

## Limitations

Onsite vehicle and equipment maintenance should only be used where it is impractical to send vehicles and equipment offsite for maintenance and repair. Sending vehicles/equipment offsite should be done in conjunction with TC-1, Stabilized Construction Entrance/Exit.

Outdoor vehicle or equipment maintenance is a potentially significant source of stormwater pollution. Activities that can contaminate stormwater include engine repair and service, changing or replacement of fluids, and outdoor equipment storage and parking (engine fluid leaks). For further information on vehicle or equipment servicing, see NS-8, Vehicle and Equipment Cleaning, and NS-9, Vehicle and Equipment Fueling.

## Objectives

EC	Erosion Control	
SE	Sediment Control	
TC	Tracking Control	
WE	Wind Erosion Control	
NS	Non-Stormwater Management Control	✓
WM	Waste Management and Materials Pollution Control	

## Legend:

- ✓ Primary Objective
- ✓ Secondary Objective

## Targeted Constituents

Sediment	
Nutrients	✓
Trash	✓
Metals	
Bacteria	
Oil and Grease	✓
Organics	✓

## Potential Alternatives

None



# **NS-10 Vehicle & Equipment Maintenance**

## **Implementation**

- Use offsite repair shops as much as possible. These businesses are better equipped to handle vehicle fluids and spills properly. Performing this work offsite can also be economical by eliminating the need for a separate maintenance area.
- If maintenance must occur onsite, use designated areas, located away from drainage courses. Dedicated maintenance areas should be protected from stormwater runoff and runoff, and should be located at least 50 ft from downstream drainage facilities and watercourses.
- Drip pans or absorbent pads should be used during vehicle and equipment maintenance work that involves fluids, unless the maintenance work is performed over an impermeable surface in a dedicated maintenance area.
- Place a stockpile of spill cleanup materials where it will be readily accessible.
- All fueling trucks and fueling areas are required to have spill kits and/or use other spill protection devices.
- Use adsorbent materials on small spills. Remove the absorbent materials promptly and dispose of properly.
- Inspect onsite vehicles and equipment daily at startup for leaks, and repair immediately.
- Keep vehicles and equipment clean; do not allow excessive build-up of oil and grease.
- Segregate and recycle wastes, such as greases, used oil or oil filters, antifreeze, cleaning solutions, automotive batteries, hydraulic and transmission fluids. Provide secondary containment and covers for these materials if stored onsite.
- Train employees and subcontractors in proper maintenance and spill cleanup procedures.
- Drip pans or plastic sheeting should be placed under all vehicles and equipment placed on docks, barges, or other structures over water bodies when the vehicle or equipment is planned to be idle for more than 1 hour.
- For long-term projects, consider using portable tents or covers over maintenance areas if maintenance cannot be performed offsite.
- Consider use of new, alternative greases and lubricants, such as adhesive greases, for chassis lubrication and fifth-wheel lubrication.
- Properly dispose of used oils, fluids, lubricants, and spill cleanup materials.
- Do not place used oil in a dumpster or pour into a storm drain or watercourse.
- Properly dispose of or recycle used batteries.
- Do not bury used tires.
- Repair leaks of fluids and oil immediately.

# **Vehicle & Equipment Maintenance NS-10**

---

Listed below is further information if you must perform vehicle or equipment maintenance onsite.

## ***Safer Alternative Products***

- Consider products that are less toxic or hazardous than regular products. These products are often sold under an “environmentally friendly” label.
- Consider use of grease substitutes for lubrication of truck fifth-wheels. Follow manufacturers label for details on specific uses.
- Consider use of plastic friction plates on truck fifth-wheels in lieu of grease. Follow manufacturers label for details on specific uses.

## ***Waste Reduction***

Parts are often cleaned using solvents such as trichloroethylene, trichloroethane, or methylene chloride. Many of these cleaners are listed in California Toxic Rule as priority pollutants. These materials are harmful and must not contaminate stormwater. They must be disposed of as a hazardous waste. Reducing the number of solvents makes recycling easier and reduces hazardous waste management costs. Often, one solvent can perform a job as well as two different solvents. Also, if possible, eliminate or reduce the amount of hazardous materials and waste by substituting non-hazardous or less hazardous materials. For example, replace chlorinated organic solvents with non-chlorinated solvents. Non-chlorinated solvents like kerosene or mineral spirits are less toxic and less expensive to dispose of properly. Check the list of active ingredients to see whether it contains chlorinated solvents. The “chlor” term indicates that the solvent is chlorinated. Also, try substituting a wire brush for solvents to clean parts.

## ***Recycling and Disposal***

Separating wastes allows for easier recycling and may reduce disposal costs. Keep hazardous wastes separate, do not mix used oil solvents, and keep chlorinated solvents (like, trichloroethane) separate from non-chlorinated solvents (like kerosene and mineral spirits). Promptly transfer used fluids to the proper waste or recycling drums. Don't leave full drip pans or other open containers lying around. Provide cover and secondary containment until these materials can be removed from the site.

Oil filters can be recycled. Ask your oil supplier or recycler about recycling oil filters.

Do not dispose of extra paints and coatings by dumping liquid onto the ground or throwing it into dumpsters. Allow coatings to dry or harden before disposal into covered dumpsters.

Store cracked batteries in a non-leaking secondary container. Do this with all cracked batteries, even if you think all the acid has drained out. If you drop a battery, treat it as if it is cracked. Put it into the containment area until you are sure it is not leaking.

## ***Costs***

All of the above are low cost measures. Higher costs are incurred to setup and maintain onsite maintenance areas.

# **NS-10 Vehicle & Equipment Maintenance**

## **Inspection and Maintenance**

- Inspect and verify that activity-based BMPs are in place prior to the commencement of associated activities. While activities associated with the BMP are under way, inspect weekly during the rainy season and at two-week intervals in the non-rainy season to verify continued BMP implementation.
- Inspect BMPs subject to non-stormwater discharges daily while non-stormwater discharges occur.
- Keep ample supplies of spill cleanup materials onsite.
- Maintain waste fluid containers in leak proof condition.
- Vehicles and equipment should be inspected on each day of use. Leaks should be repaired immediately or the problem vehicle(s) or equipment should be removed from the project site.
- Inspect equipment for damaged hoses and leaky gaskets routinely. Repair or replace as needed.

## **References**

Blueprint for a Clean Bay: Best Management Practices to Prevent Stormwater Pollution from Construction Related Activities; Santa Clara Valley Nonpoint Source Pollution Control Program, 1995.

Coastal Nonpoint Pollution Control Program; Program Development and Approval Guidance, Working Group, Working Paper; USEPA, April 1992.

Stormwater Quality Handbooks - Construction Site Best Management Practices (BMPs) Manual, State of California Department of Transportation (Caltrans), November 2000.

# Vehicle and Equipment Cleaning

# NS-8

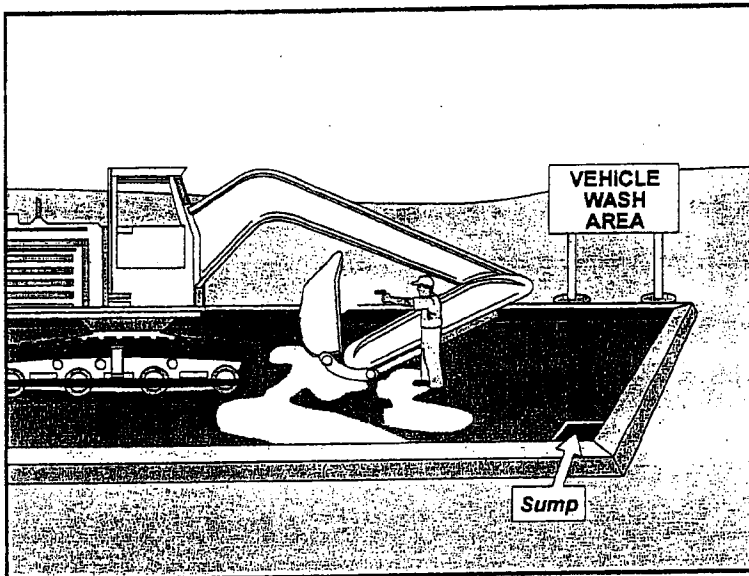

## Description and Purpose

Vehicle and equipment cleaning procedures and practices eliminate or reduce the discharge of pollutants to stormwater from vehicle and equipment cleaning operations. Procedures and practices include but are not limited to: using offsite facilities; washing in designated, contained areas only; eliminating discharges to the storm drain by infiltrating the wash water; and training employees and subcontractors in proper cleaning procedures.

## Suitable Applications

These procedures are suitable on all construction sites where vehicle and equipment cleaning is performed.

## Limitations

Even phosphate-free, biodegradable soaps have been shown to be toxic to fish before the soap degrades. Sending vehicles/equipment offsite should be done in conjunction with TC-1, Stabilized Construction Entrance/Exit.

## Implementation

Other options to washing equipment onsite include contracting with either an offsite or mobile commercial washing business. These businesses may be better equipped to handle and dispose of the wash waters properly. Performing this work offsite can also be economical by eliminating the need for a separate washing operation onsite.

If washing operations are to take place onsite, then:

## Objectives

EC	Erosion Control	
SE	Sediment Control	
TC	Tracking Control	
WE	Wind Erosion Control	
NS	Non-Stormwater Management Control	✓
WM	Waste Management and Materials Pollution Control	

## Legend:

- ✓ Primary Objective
- ✓ Secondary Objective

## Targeted Constituents

Sediment	✓
Nutrients	✓
Trash	
Metals	
Bacteria	
Oil and Grease	✓
Organics	✓

## Potential Alternatives

None





## **NS-8 Vehicle and Equipment Cleaning**

- Use phosphate-free, biodegradable soaps.
- Educate employees and subcontractors on pollution prevention measures.
- Do not permit steam cleaning onsite. Steam cleaning can generate significant pollutant concentrates.
- Cleaning of vehicles and equipment with soap, solvents or steam should not occur on the project site unless resulting wastes are fully contained and disposed of. Resulting wastes should not be discharged or buried, and must be captured and recycled or disposed according to the requirements of WM-10, Liquid Waste Management or WM-6, Hazardous Waste Management, depending on the waste characteristics. Minimize use of solvents. Use of diesel for vehicle and equipment cleaning is prohibited.
- All vehicles and equipment that regularly enter and leave the construction site must be cleaned offsite.
- When vehicle and equipment washing and cleaning must occur onsite, and the operation cannot be located within a structure or building equipped with appropriate disposal facilities, the outside cleaning area should have the following characteristics:
  - Located away from storm drain inlets, drainage facilities, or watercourses
  - Paved with concrete or asphalt and bermed to contain wash waters and to prevent runoff and runoff
  - Configured with a sump to allow collection and disposal of wash water
  - No discharge of wash waters to storm drains or watercourses
  - Used only when necessary
- When cleaning vehicles and equipment with water:
  - Use as little water as possible. High-pressure sprayers may use less water than a hose and should be considered
  - Use positive shutoff valve to minimize water usage
  - Facility wash racks should discharge to a sanitary sewer, recycle system or other approved discharge system and must not discharge to the storm drainage system, watercourses, or to groundwater

### **Costs**

Cleaning vehicles and equipment at an offsite facility may reduce overall costs for vehicle and equipment cleaning by eliminating the need to provide similar services onsite. When onsite cleaning is needed, the cost to establish appropriate facilities is relatively low on larger, long-duration projects, and moderate to high on small, short-duration projects.

## **Inspection and Maintenance**

- Inspect and verify that activity-based BMPs are in place prior to the commencement of associated activities. While activities associated with the BMP are under way, inspect weekly during the rainy season and at two-week intervals in the non-rainy season to verify continued BMP implementation.
- Inspect BMPs subject to non-stormwater discharges daily while non-stormwater discharges occur.
- Inspection and maintenance is minimal, although some berm repair may be necessary.
- Monitor employees and subcontractors throughout the duration of the construction project to ensure appropriate practices are being implemented.
- Inspect sump regularly and remove liquids and sediment as needed.
- Prohibit employees and subcontractors from washing personal vehicles and equipment on the construction site.

## **References**

Stormwater Quality Handbooks - Construction Site Best Management Practices (BMPs) Manual, State of California Department of Transportation (Caltrans), November 2000.

Swisher, R.D. Surfactant Biodegradation, Marcel Decker Corporation, 1987.

# Spill Prevention, Control & Cleanup SC-11

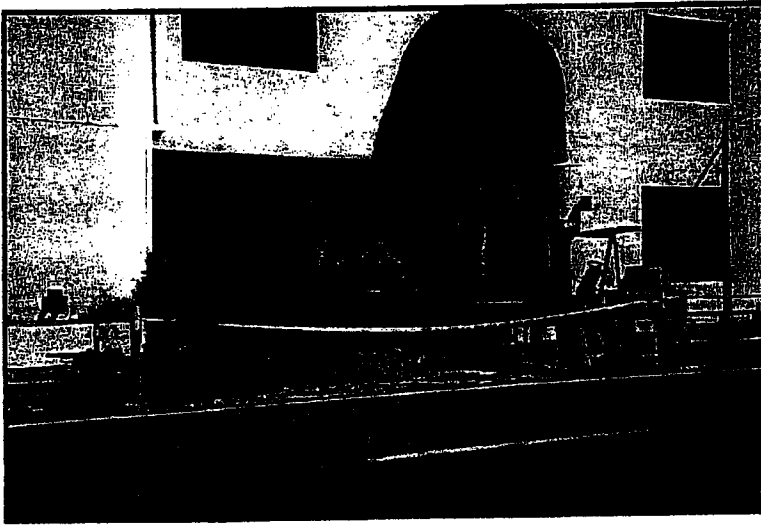

## Objectives

- Cover
- Contain
- Educate
- Reduce/Minimize
- Product Substitution

## Description

Spills and leaks, if not properly controlled, can adversely impact the storm drain system and receiving waters. Due to the type of work or the materials involved, many activities that occur either at a municipal facility or as a part of municipal field programs have the potential for accidental spills and leaks. Proper spill response planning and preparation can enable municipal employees to effectively respond to problems when they occur and minimize the discharge of pollutants to the environment.

## Approach

- An effective spill response and control plan should include:
  - Spill/leak prevention measures;
  - Spill response procedures;
  - Spill cleanup procedures;
  - Reporting; and
  - Training
- A well thought out and implemented plan can prevent pollutants from entering the storm drainage system and can be used as a tool for training personnel to prevent and control future spills as well.

## Pollution Prevention

- Develop and implement a Spill Prevention Control and Response Plan. The plan should include:

## Targeted Constituents

Sediment	
Nutrients	✓
Trash	
Metals	✓
Bacteria	
Oil and Grease	✓
Organics	✓
Oxygen Demanding	✓



# **SC-11 Spill Prevention, Control & Cleanup**

- A description of the facility, the address, activities and materials involved
- Identification of key spill response personnel
- Identification of the potential spill areas or operations prone to spills/leaks
- Identification of which areas should be or are bermed to contain spills/leaks
- Facility map identifying the key locations of areas, activities, materials, structural BMPs, etc.
- Material handling procedures
- Spill response procedures including:
  - Assessment of the site and potential impacts
  - Containment of the material
  - Notification of the proper personnel and evacuation procedures
  - Clean up of the site
  - Disposal of the waste material and
  - Proper record keeping
- Product substitution – use less toxic materials (i.e. use water based paints instead of oil based paints)
- Recycle, reclaim, or reuse materials whenever possible. This will reduce the amount of materials that are brought into the facility or into the field.

## ***Suggested Protocols***

### *Spill/Leak Prevention Measures*

- If possible, move material handling indoors, under cover, or away from storm drains or sensitive water bodies.
- Properly label all containers so that the contents are easily identifiable.
- Berm storage areas so that if a spill or leak occurs, the material is contained.
- Cover outside storage areas either with a permanent structure or with a seasonal one such as a tarp so that rain can not come into contact with the materials.
- Check containers (and any containment sumps) often for leaks and spills. Replace containers that are leaking, corroded, or otherwise deteriorating with containers in good condition. Collect all spilled liquids and properly dispose of them.

# **Spill Prevention, Control & Cleanup SC-11**

- Store, contain and transfer liquid materials in such a manner that if the container is ruptured or the contents spilled, they will not discharge, flow or be washed into the storm drainage system, surface waters, or groundwater.
- Place drip pans or absorbent materials beneath all mounted taps and at all potential drip and spill locations during the filling and unloading of containers. Any collected liquids or soiled absorbent materials should be reused/recycled or properly disposed of.
- For field programs, only transport the minimum amount of material needed for the daily activities and transfer materials between containers at a municipal yard where leaks and spill are easier to control.
- If paved, sweep and clean storage areas monthly, do not use water to hose down the area unless all of the water will be collected and disposed of properly.
- Install a spill control device (such as a tee section) in any catch basins that collect runoff from any storage areas if the materials stored are oil, gas, or other materials that separate from and float on water. This will allow for easier cleanup if a spill occurs.
- If necessary, protect catch basins while conducting field activities so that if a spill occurs, the material will be contained.

## ***Training***

- Educate employees about spill prevention, spill response and cleanup on a routine basis.
- Well-trained employees can reduce human errors that lead to accidental releases or spills:
  - The employees should have the tools and knowledge to immediately begin cleaning up a spill if one should occur.
  - Employees should be familiar with the Spill Prevention Control and Countermeasure Plan if one is available.
- Training of staff from all municipal departments should focus on recognizing and reporting potential or current spills/leaks and who they should contact.
- Employees responsible for aboveground storage tanks and liquid transfers for large bulk containers should be thoroughly familiar with the Spill Prevention Control and Countermeasure Plan and the plan should be readily available.

## ***Spill Response and Prevention***

- Identify key spill response personnel and train employees on who they are.
- Store and maintain appropriate spill cleanup materials in a clearly marked location near storage areas; and train employees to ensure familiarity with the site's spill control plan and/or proper spill cleanup procedures.
- Locate spill cleanup materials, such as absorbents, where they will be readily accessible (e.g. near storage and maintenance areas, on field trucks).

# **SC-11 Spill Prevention, Control & Cleanup**

- Follow the Spill Prevention Control and Countermeasure Plan if one is available.
- If a spill occurs, notify the key spill response personnel immediately. If the material is unknown or hazardous, the local fire department may also need to be contacted.
- If safe to do so, attempt to contain the material and block the nearby storm drains so that the area impacted is minimized. If the material is unknown or hazardous wait for properly trained personnel to contain the materials.
- Perform an assessment of the area where the spill occurred and the downstream area that it could impact. Relay this information to the key spill response and clean up personnel.

## *Spill Cleanup Procedures*

- Small non-hazardous spills
  - Use a rag, damp cloth or absorbent materials for general clean up of liquids
  - Use brooms or shovels for the general clean up of dry materials
  - If water is used, it must be collected and properly disposed of. The wash water can not be allowed to enter the storm drain.
  - Dispose of any waste materials properly
  - Clean or dispose of any equipment used to clean up the spill properly
- Large non-hazardous spills
  - Use absorbent materials for general clean up of liquids
  - Use brooms, shovels or street sweepers for the general clean up of dry materials
  - If water is used, it must be collected and properly disposed of. The wash water can not be allowed to enter the storm drain.
  - Dispose of any waste materials properly
  - Clean or dispose of any equipment used to clean up the spill properly
- For hazardous or very large spills, a private cleanup company or Hazmat team may need to be contacted to assess the situation and conduct the cleanup and disposal of the materials.
- Chemical cleanups of material can be achieved with the use of absorbents, gels, and foams. Remove the adsorbent materials promptly and dispose of according to regulations.
- If the spilled material is hazardous, then the used cleanup materials are also hazardous and must be sent to a certified laundry (rags) or disposed of as hazardous waste.

## *Reporting*

- Report any spills immediately to the identified key municipal spill response personnel.

# **Spill Prevention, Control & Cleanup SC-11**

- Report spills in accordance with applicable reporting laws. Spills that pose an immediate threat to human health or the environment must be reported immediately to the Office of Emergency Service (OES)
- Spills that pose an immediate threat to human health or the environment may also need to be reported within 24 hours to the Regional Water Quality Control Board.
- Federal regulations require that any oil spill into a water body or onto an adjoining shoreline be reported to the National Response Center (NRC) at 800-424-8802 (24 hour)
- After the spill has been contained and cleaned up, a detailed report about the incident should be generated and kept on file (see the section on Reporting below). The incident may also be used in briefing staff about proper procedures

## ***Other Considerations***

- State regulations exist for facilities with a storage capacity of 10,000 gallons or more of petroleum to prepare a Spill Prevention Control and Countermeasure Plan (SPCC) Plan (Health & Safety Code Chapter 6.67).
- State regulations also exist for storage of hazardous materials (Health & Safety Code Chapter 6.95), including the preparation of area and business plans for emergency response to the releases or threatened releases.
- Consider requiring smaller secondary containment areas (less than 200 sq. ft.) to be connected to the sanitary sewer, if permitted to do so, prohibiting any hard connections to the storm drain.

## **Requirements**

### ***Costs***

- Will vary depending on the size of the facility and the necessary controls.
- Prevention of leaks and spills is inexpensive. Treatment and/or disposal of wastes, contaminated soil and water is very expensive

### ***Maintenance***

- This BMP has no major administrative or staffing requirements. However, extra time is needed to properly handle and dispose of spills, which results in increased labor costs

## **Supplemental Information**

### ***Further Detail of the BMP***

#### ***Reporting***

Record keeping and internal reporting represent good operating practices because they can increase the efficiency of the response and containment of a spill. A good record keeping system helps the municipality minimize incident recurrence, correctly respond with appropriate containment and cleanup activities, and comply with legal requirements.

# **SC-11 Spill Prevention, Control & Cleanup**

A record keeping and reporting system should be set up for documenting spills, leaks, and other discharges, including discharges of hazardous substances in reportable quantities. Incident records describe the quality and quantity of non-stormwater discharges to the storm drain.

These records should contain the following information:

- Date and time of the incident
- Weather conditions
- Duration of the spill/leak/discharge
- Cause of the spill/leak/discharge
- Response procedures implemented
- Persons notified
- Environmental problems associated with the spill/leak/discharge

Separate record keeping systems should be established to document housekeeping and preventive maintenance inspections, and training activities. All housekeeping and preventive maintenance inspections should be documented. Inspection documentation should contain the following information:

- The date and time the inspection was performed
- Name of the inspector
- Items inspected
- Problems noted
- Corrective action required
- Date corrective action was taken

Other means to document and record inspection results are field notes, timed and dated photographs, videotapes, and drawings and maps.

## ***Examples***

The City of Palo Alto includes spill prevention and control as a major element of its highly effective program for municipal vehicle maintenance shops.

## **References and Resources**

King County Stormwater Pollution Control Manual - <http://dnr.metrokc.gov/wlr/dss/spcm.htm>

Orange County Stormwater Program  
[http://www.ocwatersheds.com/stormwater/swp\\_introduction.asp](http://www.ocwatersheds.com/stormwater/swp_introduction.asp)



# **Spill Prevention, Control & Cleanup SC-11**

San Diego Stormwater Co-permittees Jurisdictional Urban Runoff Management Program  
(URMP)

<http://www.projectcleanwater.org/pdf/Model%20Program%20Municipal%20Facilities.pdf>

## Description

Promote efficient and safe housekeeping practices (storage, use, and cleanup) when handling potentially harmful materials such as fertilizers, pesticides, cleaning solutions, paint products, automotive products, and swimming pool chemicals. Related information is provided in BMP fact sheets SC-11 Spill Prevention, Control & Cleanup and SC-34 Waste Handling & Disposal.

## Approach

### Pollution Prevention

- Purchase only the amount of material that will be needed for foreseeable use. In most cases this will result in cost savings in both purchasing and disposal. See SC-61 Safer Alternative Products for additional information.
- Be aware of new products that may do the same job with less environmental risk and for less or the equivalent cost. Total cost must be used here; this includes purchase price, transportation costs, storage costs, use related costs, clean up costs and disposal costs.

### Suggested Protocols

#### General

- Keep work sites clean and orderly. Remove debris in a timely fashion. Sweep the area.
- Dispose of wash water, sweepings, and sediments, properly.
- Recycle or dispose of fluids properly.
- Establish a daily checklist of office, yard and plant areas to confirm cleanliness and adherence to proper storage and security. Specific employees should be assigned specific inspection responsibilities and given the authority to remedy any problems found.
- Post waste disposal charts in appropriate locations detailing for each waste its hazardous nature (poison, corrosive, flammable), prohibitions on its disposal (dumpster, drain, sewer) and the recommended disposal method (recycle, sewer, burn, storage, landfill).
- Summarize the chosen BMPs applicable to your operation and post them in appropriate conspicuous places.

## Objectives

- Cover
- Contain
- Educate
- Reduce/Minimize
- Product Substitution

## Targeted Constituents

Sediment	✓
Nutrients	✓
Trash	✓
Metals	✓
Bacteria	✓
Oil and Grease	✓
Organics	✓
Oxygen Demanding	✓



- Require a signed checklist from every user of any hazardous material detailing amount taken, amount used, amount returned and disposal of spent material.
- Do a before audit of your site to establish baseline conditions and regular subsequent audits to note any changes and whether conditions are improving or deteriorating.
- Keep records of water, air and solid waste quantities and quality tests and their disposition.
- Maintain a mass balance of incoming, outgoing and on hand materials so you know when there are unknown losses that need to be tracked down and accounted for.
- Use and reward employee suggestions related to BMPs, hazards, pollution reduction, work place safety, cost reduction, alternative materials and procedures, recycling and disposal.
- Have, and review regularly, a contingency plan for spills, leaks, weather extremes etc. Make sure all employees know about it and what their role is so that it comes into force automatically.

***Training***

- Train all employees, management, office, yard, manufacturing, field and clerical in BMPs and pollution prevention and make them accountable.
- Train municipal employees who handle potentially harmful materials in good housekeeping practices.
- Train personnel who use pesticides in the proper use of the pesticides. The California Department of Pesticide Regulation license pesticide dealers, certify pesticide applicators and conduct onsite inspections.
- Train employees and contractors in proper techniques for spill containment and cleanup. The employee should have the tools and knowledge to immediately begin cleaning up a spill if one should occur.

***Spill Response and Prevention***

- Refer to SC-11, Spill Prevention, Control & Cleanup.
- Keep your Spill Prevention Control and Countermeasure (SPCC) plan up-to-date, and implement accordingly.
- Have spill cleanup materials readily available and in a known location.
- Cleanup spills immediately and use dry methods if possible.
- Properly dispose of spill cleanup material.

***Other Considerations***

- There are no major limitations to this best management practice.
- There are no regulatory requirements to this BMP. Existing regulations already require municipalities to properly store, use, and dispose of hazardous materials

***Materials***

- Silt fence fabric should be woven polypropylene with a minimum width of 36 in. and a minimum tensile strength of 100 lb force. The fabric should conform to the requirements in ASTM designation D4632 and should have an integral reinforcement layer. The reinforcement layer should be a polypropylene, or equivalent, net provided by the manufacturer. The permittivity of the fabric should be between  $0.1 \text{ sec}^{-1}$  and  $0.15 \text{ sec}^{-1}$  in conformance with the requirements in ASTM designation D4491.
- Wood stakes should be commercial quality lumber of the size and shape shown on the plans. Each stake should be free from decay, splits or cracks longer than the thickness of the stake or other defects that would weaken the stakes and cause the stakes to be structurally unsuitable.
- Staples used to fasten the fence fabric to the stakes should be not less than 1.75 in. long and should be fabricated from 15 gauge or heavier wire. The wire used to fasten the tops of the stakes together when joining two sections of fence should be 9 gauge or heavier wire. Galvanizing of the fastening wire will not be required.
- There are new products that may use prefabricated plastic holders for the silt fence and use bar reinforcement instead of wood stakes. If bar reinforcement is used in lieu of wood stakes, use number four or greater bar. Provide end protection for any exposed bar reinforcement.

***Installation Guidelines***

Silt fences are to be constructed on a level contour. Sufficient area should exist behind the fence for ponding to occur without flooding or overtopping the fence.

- A trench should be excavated approximately 6 in. wide and 6 in. deep along the line the proposed silt fence.
- Bottom of the silt fence should be keyed-in a minimum of 12 in.
- Posts should be spaced a maximum of 6 ft apart and driven securely into the ground a minimum of 18 in. or 12 in. below the bottom of the trench.
- When standard strength filter fabric is used, a plastic or wire mesh support fence should be fastened securely to the upslope side of posts using heavy-duty wire staples at least 1 in. long. The mesh should extend into the trench. When extra-strength filter fabric and closer post spacing are used, the mesh support fence may be eliminated. Filter fabric should be purchased in a long roll, then cut to the length of the barrier. When joints are necessary, filter cloth should be spliced together only at a support post, with a minimum 6 in. overlap and both ends securely fastened to the post.
- The trench should be backfilled with compacted native material.
- Construct silt fences with a setback of at least 3 ft from the toe of a slope. Where a silt fence is determined to be not practicable due to specific site conditions, the silt fence may be constructed at the toe of the slope, but should be constructed as far from the toe of the slope as practicable. Silt fences close to the toe of the slope will be less effective and difficult to maintain.

- Construct the length of each reach so that the change in base elevation along the reach does not exceed 1/3 the height of the barrier; in no case should the reach exceed 500 ft.

## Costs

- Average annual cost for installation and maintenance (assumes 6 month useful life): \$7 per lineal foot (\$850 per drainage acre). Range of cost is \$3.50 - \$9.10 per lineal foot.

## Inspection and Maintenance

- Inspect BMPs prior to forecast rain, daily during extended rain events, after rain events, weekly during the rainy season, and at two-week intervals during the non-rainy season.
- Repair undercut silt fences.
- Repair or replace split, torn, slumping, or weathered fabric. The lifespan of silt fence fabric is generally 5 to 8 months.
- Silt fences that are damaged and become unsuitable for the intended purpose should be removed from the site of work, disposed of, and replaced with new silt fence barriers.
- Sediment that accumulates in the BMP must be periodically removed in order to maintain BMP effectiveness. Sediment should be removed when the sediment accumulation reaches one-third of the barrier height. Sediment removed during maintenance may be incorporated into earthwork on the site or disposed at an appropriate location.
- Silt fences should be left in place until the upstream area is permanently stabilized. Until then, the silt fence must be inspected and maintained.
- Holes, depressions, or other ground disturbance caused by the removal of the silt fences should be backfilled and repaired.

## References

Manual of Standards of Erosion and Sediment Control Measures, Association of Bay Area Governments, May 1995.

National Management Measures to Control Nonpoint Source Pollution from Urban Areas, United States Environmental Protection Agency, 2002.

Proposed Guidance Specifying Management Measures for Sources of Nonpoint Pollution in Coastal Waters, Work Group-Working Paper, USEPA, April 1992.

Sedimentation and Erosion Control Practices, and Inventory of Current Practices (Draft), UESPA, 1990.

Southeastern Wisconsin Regional Planning Commission (SWRPC). Costs of Urban Nonpoint Source Water Pollution Control Measures. Technical Report No. 31. Southeastern Wisconsin Regional Planning Commission, Waukesha, WI. 1991

Stormwater Quality Handbooks - Construction Site Best Management Practices (BMPs) Manual, State of California Department of Transportation (Caltrans), November 2000.

Stormwater Management Manual for The Puget Sound Basin, Washington State Department of Ecology, Public Review Draft, 1991.

U.S. Environmental Protection Agency (USEPA). Stormwater Management for Industrial Activities: Developing Pollution Prevention Plans and Best Management Practices. U.S. Environmental Protection Agency, Office of Water, Washington, DC, 1992.

Water Quality Management Plan for the Lake Tahoe Region, Volume II, Handbook of Management Practices, Tahoe Regional Planning Agency, November 1988.

# Silt Fence

SE-1

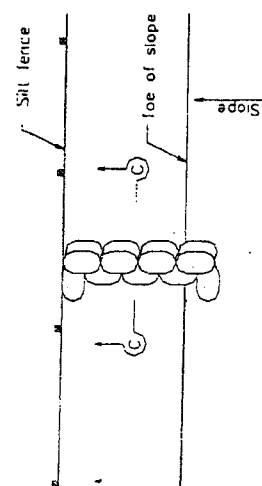
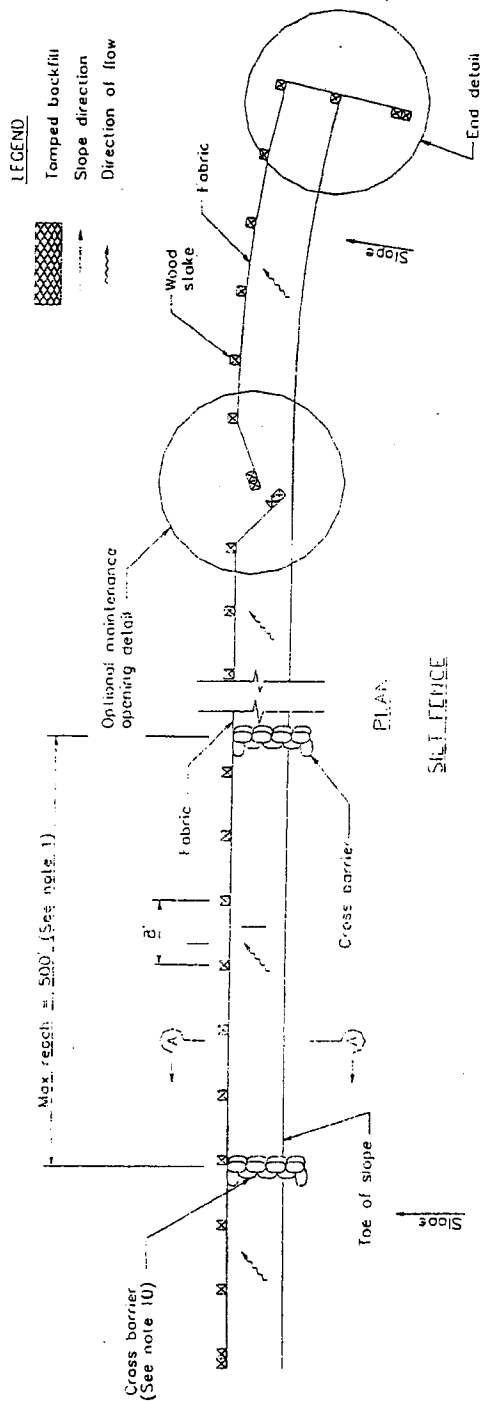

CROSS BARRIER DETAIL

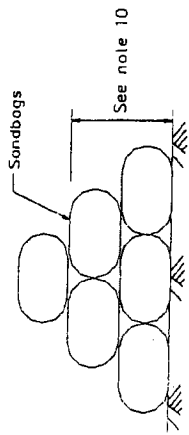

**NOTES**

1. Construct the length of each reach so that the change in base elevation along the reach does not exceed 1/3 the height of the linear barrier, in no case shall the reach length exceed 500'.
2. The last 8'-0" of fence shall be turned up slope.
3. Stake dimensions are nominal.
4. Dimension may vary to fit field condition.
5. Stakes shall be spaced at 8'-0" maximum and shall be positioned on downstream side of fence.
6. Stakes to overlap and fence fabric to fold around each stake one full turn. Secure fabric to stakes with 4 staples.
7. Stakes shall be driven tightly together to prevent potential flow-through of sediment at joint. The tops of the stakes shall be secured with wire.
8. For end stake, fence fabric shall be folded around two stakes one full turn and secured with 4 staples.
9. Minimum 4 staples per stake. Dimensions shown are typical.
10. Cross barriers shall be a minimum of 1/3 and a maximum of 1/2 the height of the linear barrier.
11. Maintenance openings shall be constructed in a manner to ensure sediment remains behind silt fence.
12. Joining sections shall not be placed at sump locations.
13. Sandbag rows and layers shall be offset to eliminate gaps.

**LEGEND**  
 Tamped backfill  
 Slope direction  
 Direction of flow

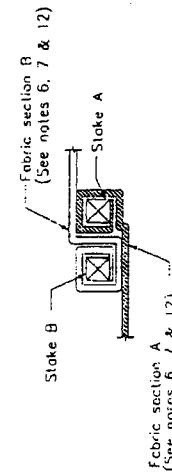

**JOINING SECTION DETAIL (TOP VIEW)**

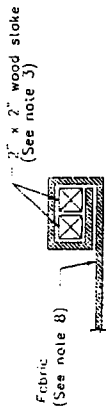

**END STAKE DETAIL (TOP VIEW)**

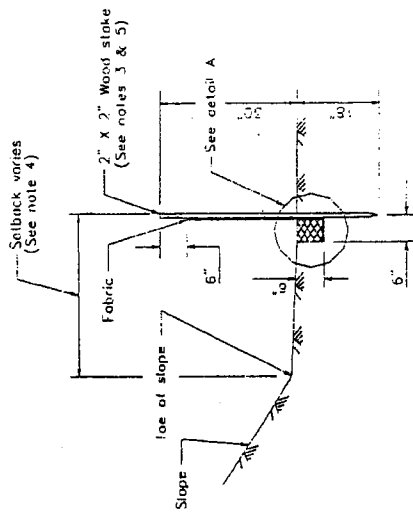

**SECTION A-A**

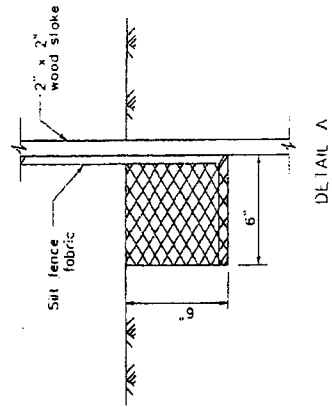

**DETAIL A-A**

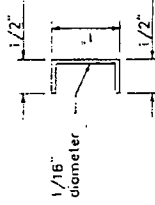

**STAPLE DETAIL**  
 (SEE NOTE 9)

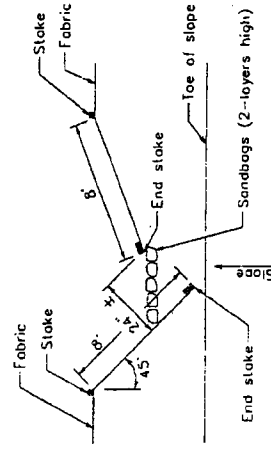

**OPTIONAL MAINTENANCE OPENING DETAIL**  
 (SEE NOTE 11)

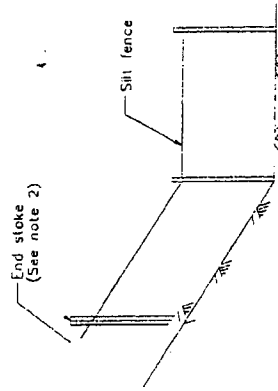

**END DETAIL**



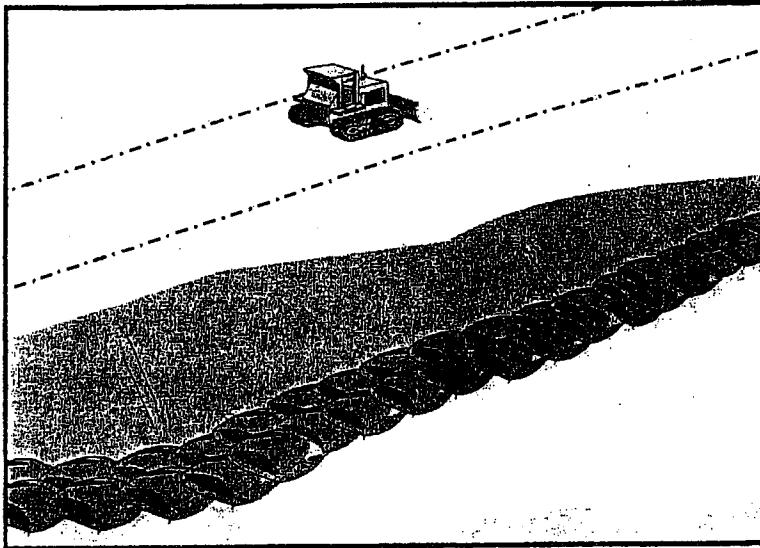

## Description and Purpose

A sandbag barrier is a series of sand-filled bags placed on a level contour to intercept sheet flows. Sandbag barriers pond sheet flow runoff, allowing sediment to settle out.

## Suitable Applications

Sandbag barriers may be suitable:

- As a linear sediment control measure:
  - Below the toe of slopes and erodible slopes
  - As sediment traps at culvert/pipe outlets
  - Below other small cleared areas
  - Along the perimeter of a site
  - Down slope of exposed soil areas
  - Around temporary stockpiles and spoil areas
  - Parallel to a roadway to keep sediment off paved areas
  - Along streams and channels
- As linear erosion control measure:
  - Along the face and at grade breaks of exposed and erodible slopes to shorten slope length and spread runoff as sheet flow

## Objectives

EC	Erosion Control	✓
SE	Sediment Control	✓
TC	Tracking Control	
WE	Wind Erosion Control	
NS	Non-Stormwater Management Control	
WM	Waste Management and Materials Pollution Control	

## Legend:

- ✓ Primary Objective
- ✓ Secondary Objective

## Targeted Constituents

Sediment	✓
Nutrients	
Trash	
Metals	
Bacteria	
Oil and Grease	
Organics	

## Potential Alternatives

- SE-1 Silt Fence
- SE-5 Fiber Rolls
- SE-6 Gravel Bag Berm
- SE-9 Straw Bale Barrier



- At the top of slopes to divert runoff away from disturbed slopes
- As check dams across mildly sloped construction roads

**Limitations**

- It is necessary to limit the drainage area upstream of the barrier to 5 acres.
- Degraded sandbags may rupture when removed, spilling sand.
- Installation can be labor intensive.
- Barriers may have limited durability for long-term projects.
- When used to detain concentrated flows, maintenance requirements increase.
- Burlap should not be used for sandbags.

**Implementation****General**

A sandbag barrier consists of a row of sand-filled bags placed on a level contour. When appropriately placed, a sandbag barrier intercepts and slows sheet flow runoff, causing temporary ponding. The temporary ponding provides quiescent conditions allowing sediment to settle. While the sand-filled bags are porous, the fine sand tends to quickly plug with sediment, limiting the rate of flow through the barrier. If a porous barrier is desired, consider SE-1, Silt Fence, SE-5, Fiber Rolls, SE-6, Gravel Bag Berms, or SE-9, Straw Bale Barriers. Sandbag barriers also interrupt the slope length and thereby reduce erosion by reducing the tendency of sheet flows to concentrate into rivulets which erode rills, and ultimately gullies, into disturbed, sloped soils. Sandbag barriers are similar to ground bag berms, but less porous.

**Design and Layout**

- Locate sandbag barriers on a level contour.
  - Slopes between 20:1 and 2:1 (H:V): Sandbags should be placed at a maximum interval of 50 ft (a closer spacing is more effective), with the first row near the slope toe.
  - Slopes 2:1 (H:V) or steeper: Sandbags should be placed at a maximum interval of 25 ft (a closer spacing is more effective), with the first row placed near the slope toe.
- Turn the ends of the sandbag barrier up slope to prevent runoff from going around the barrier.
- Allow sufficient space up slope from the barrier to allow ponding, and to provide room for sediment storage.
- For installation near the toe of the slope, consider moving the barrier away from the slope toe to facilitate cleaning. To prevent flow behind the barrier, sandbags can be placed perpendicular to the barrier to serve as cross barriers.
- Drainage area should not exceed 5 acres.

- Stack sandbags at least three bags high.
- Butt ends of bags tightly.
- Overlapp butt joints of row beneath with each successive row.
- Use a pyramid approach when stacking bags.
- In non-traffic areas
  - Height = 18 in. maximum
  - Top width = 24 in. minimum for three or more layer construction
  - Side slope = 2:1 or flatter
- In construction traffic areas
  - Height = 12 in. maximum
  - Top width = 24 in. minimum for three or more layer construction.
  - Side slopes = 2:1 or flatter.

## Materials

- **Sandbag Material:** Sandbag should be woven polypropylene, polyethylene or polyamide fabric, minimum unit weight of 4 ounces/yd<sup>2</sup>, Mullen burst strength exceeding 300 lb/in<sup>2</sup> in conformance with the requirements in ASTM designation D3786, and ultraviolet stability exceeding 70% in conformance with the requirements in ASTM designation D4355. Use of burlap may not acceptable in some jurisdictions.
- **Sandbag Size:** Each sand-filled bag should have a length of 18 in., width of 12 in., thickness of 3 in., and mass of approximately 33 lbs. Bag dimensions are nominal, and may vary based on locally available materials.
- **Fill Material:** All sandbag fill material should be non-cohesive, Class 1 or Class 2 permeable material free from clay and deleterious material.

## Costs

Sandbag barriers are more costly, but typically have a longer useful life than other barriers. Empty sandbags cost \$0.25 - \$0.75. Average cost of fill material is \$8 per yd<sup>3</sup>. Pre-filled sandbags are more expensive at \$1.50 - \$2.00 per bag.

## Inspection and Maintenance

- Inspect BMPs prior to forecast rain, daily during extended rain events, after rain events, weekly during the rainy season, and at two-week intervals during the non-rainy season.
- Sandbags exposed to sunlight will need to be replaced every two to three months due to degradation of the bags.
- Reshape or replace sandbags as needed.

- Repair washouts or other damage as needed.
- Sediment that accumulates in the BMP must be periodically removed in order to maintain BMP effectiveness. Sediment should be removed when the sediment accumulation reaches one-third of the barrier height. Sediment removed during maintenance may be incorporated into earthwork on the site or disposed at an appropriate location.
- Remove sandbags when no longer needed. Remove sediment accumulation, and clean, re-grade, and stabilize the area.

**References**

Stormwater Quality Handbooks - Construction Site Best Management Practices (BMPs) Manual, State of California Department of Transportation (Caltrans), November 2000.

# Sandbag Barrier

SE-8

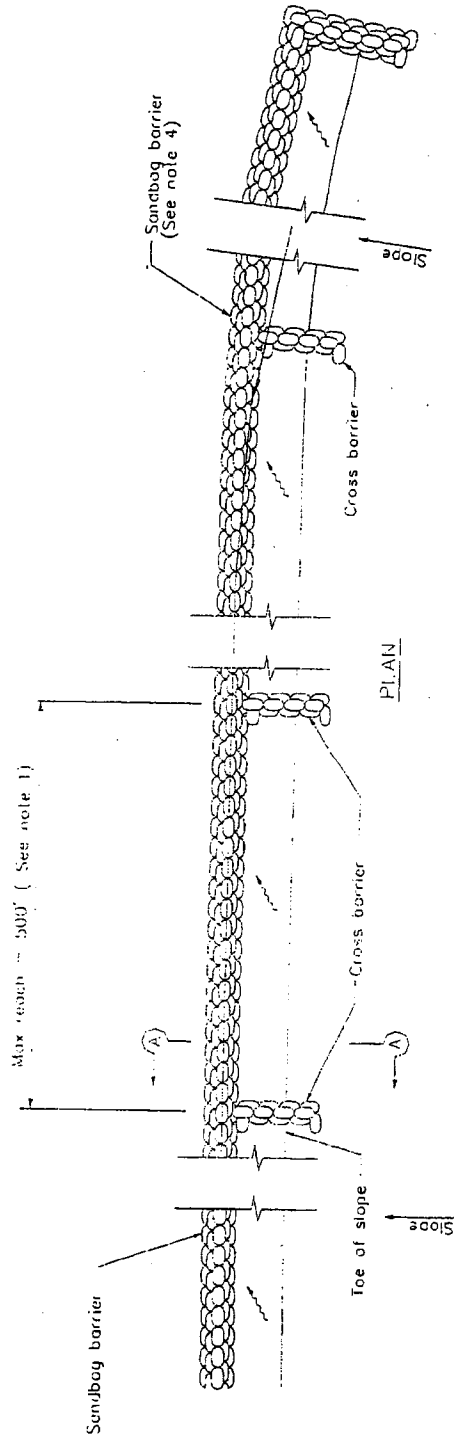

## SANDBAG BARRIER

### NOTES

1. Construct the length of each reach so that the change in base elevation along the reach does not exceed  $1/2$  the height of the linear barrier. In no case shall the reach length exceed 500'.
2. Place sandbags tightly.
3. Dimension may vary to fit field condition.
4. Sandbag barrier shall be a minimum of 3 bags high.
5. The end of the barrier shall be turned up slope.
6. Cross barriers shall be a min of  $1/2$  and a max of  $2/3$  the height of the linear barrier.
7. Sandbag rows and layers shall be staggered to eliminate gaps.

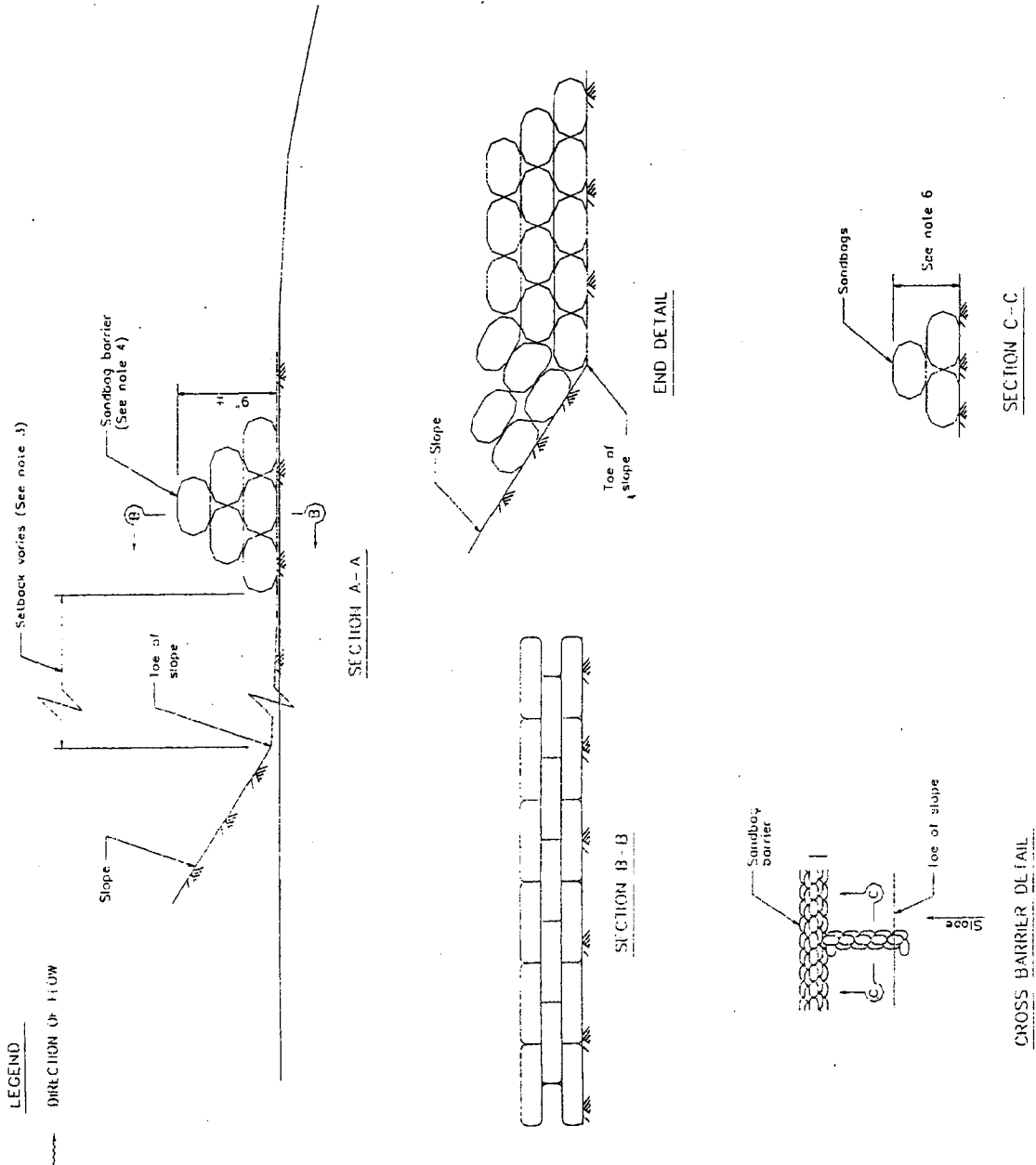

**Inspection and Maintenance*****Maintenance***

- Inspect BMPs prior to forecast rain, daily during extended rain events, after rain events, weekly during the rainy season, and at two-week intervals during the non-rainy season.
- Straw bales degrade, especially when exposed to moisture. Rotting bales will need to be replaced on a regular basis.
- Replace or repair damaged bales as needed.
- Repair washouts or other damages as needed.
- Sediment that accumulates in the BMP must be periodically removed in order to maintain BMP effectiveness. Sediment should be removed when the sediment accumulation reaches one-third of the barrier height. Sediment removed during maintenance may be incorporated into earthwork on the site or disposed at an appropriate location.
- Remove straw bales when no longer needed. Remove sediment accumulation, and clean, re-grade, and stabilize the area. Removed sediment should be incorporated in the project or disposed of.

**References**

Stormwater Quality Handbooks - Construction Site Best Management Practices (BMPs) Manual, State of California Department of Transportation (Caltrans), November 2000.

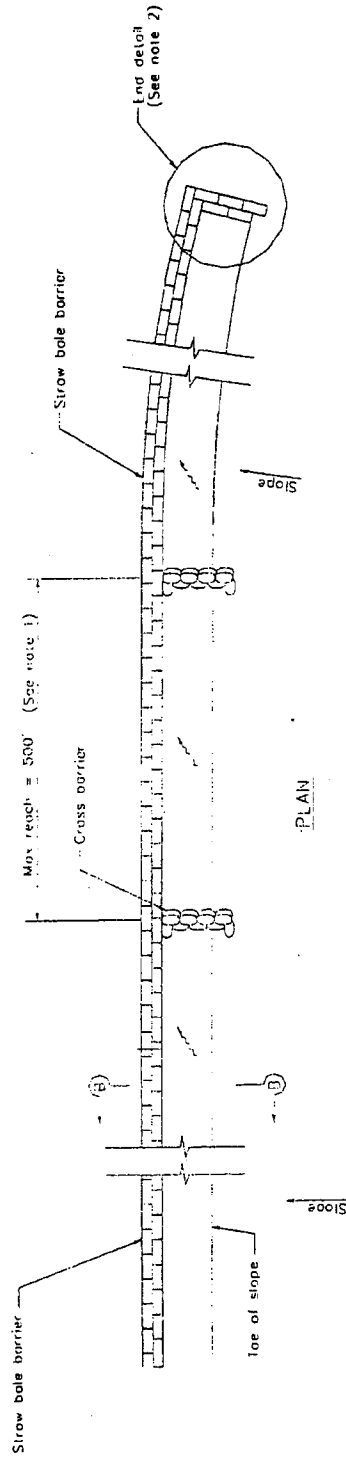

### NOTES

1. Construct the length of each reach so that the change in base elevation along the reach does not exceed  $1/2$  the height of the linear barrier. In no case shall the reach length exceed 500'.
2. The end of barrier shall be turned up slope.
3. Dimension may vary to fit field condition.
4. Stake dimensions are nominal.
5. Place straw bales tightly together.
6. Temp embedment spurs against sides of installed bales.
7. Drive angled wood stake before vertical stake to ensure light abutment to adjacent bale.
8. Sandbag cross barriers should be a min of  $1/2$  and a max of  $2/3$  the height of the linear barrier.
9. Sandbag rows and layers should be offset to eliminate gaps.

### LEGEND

--- DIRECTION OF FLOW



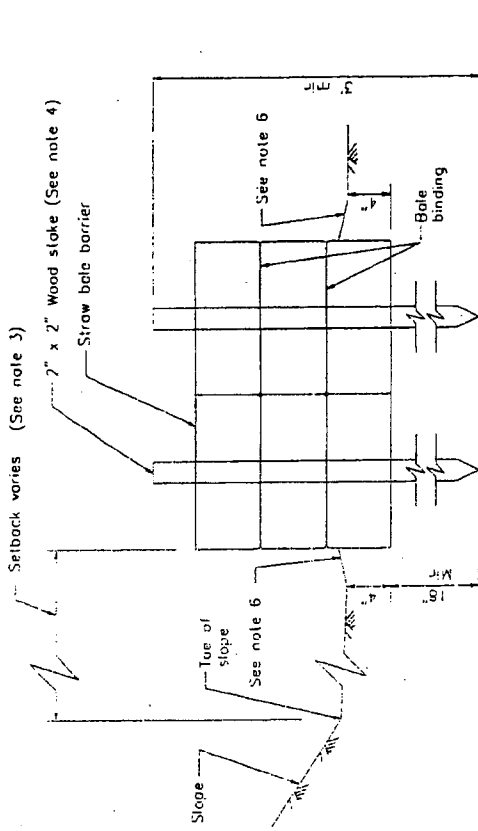

SECTION B-B

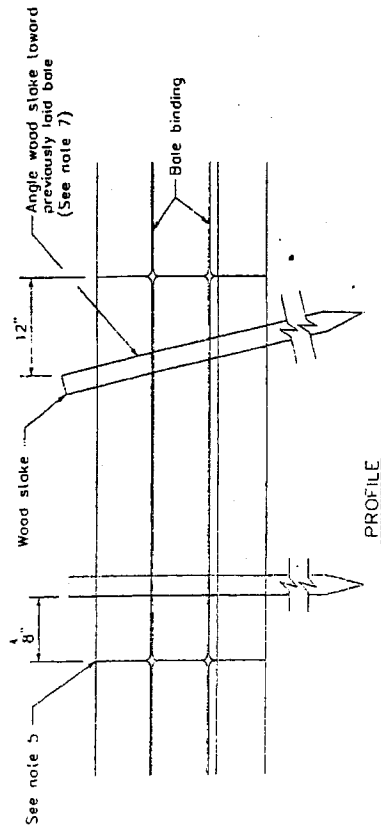

PROFILE

LEGEND  
DIRECTION OF FLOW

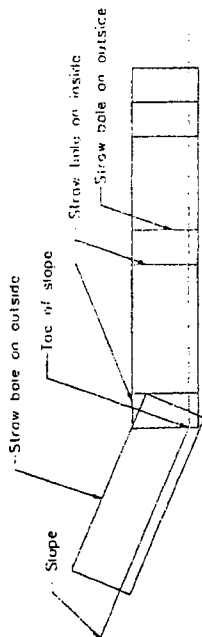

END DETAIL

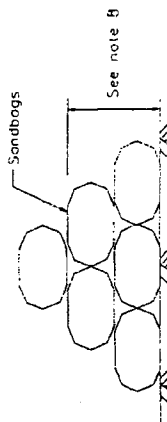

SANDBAG CROSS BARRIER

## Dust Control Practices

Dust control BMPs generally stabilize exposed surfaces and minimize activities that suspend or track dust particles. The following table shows dust control practices that can be applied to site conditions that cause dust. For heavily traveled and disturbed areas, wet suppression (watering), chemical dust suppression, gravel asphalt surfacing, temporary gravel construction entrances, equipment wash-out areas, and haul truck covers can be employed as dust control applications. Permanent or temporary vegetation and mulching can be employed for areas of occasional or no construction traffic. Preventive measures would include minimizing surface areas to be disturbed, limiting onsite vehicle traffic to 15 mph, and controlling the number and activity of vehicles on a site at any given time.

SITE CONDITION	DUST CONTROL PRACTICES								
	Permanent Vegetation	Mulching	Wet Suppression (Watering)	Chemical Dust Suppression	Gravel or Asphalt	Silt Fences	Temporary Gravel Construction Entrances/Equipment Wash Down	Haul Truck Covers	Minimize Extent of Disturbed Area
Disturbed Areas not Subject to Traffic	X	X	X	X	X				X
Disturbed Areas Subject to Traffic			X	X	X		X		X
Material Stock Pile Stabilization			X	X		X			X
Demolition			X				X	X	
Clearing/Excavation			X	X		X			X
Truck Traffic on Unpaved Roads			X	X	X		X	X	
Mud/Dirt Carry Out					X		X		

Additional preventive measures include:

- Schedule construction activities to minimize exposed area (EC-1, Scheduling).
- Quickly stabilize exposed soils using vegetation, mulching, spray-on adhesives, calcium chloride, sprinkling, and stone/gravel layering.
- Identify and stabilize key access points prior to commencement of construction.
- Minimize the impact of dust by anticipating the direction of prevailing winds.
- Direct most construction traffic to stabilized roadways within the project site.
- Water should be applied by means of pressure-type distributors or pipelines equipped with a spray system or hoses and nozzles that will ensure even distribution.
- All distribution equipment should be equipped with a positive means of shutoff.
- Unless water is applied by means of pipelines, at least one mobile unit should be available at all times to apply water or dust palliative to the project.

- If reclaimed waste water is used, the sources and discharge must meet California Department of Health Services water reclamation criteria and the Regional Water Quality Control Board requirements. Non-potable water should not be conveyed in tanks or drain pipes that will be used to convey potable water and there should be no connection between potable and non-potable supplies. Non-potable tanks, pipes, and other conveyances should be marked, "NON-POTABLE WATER - DO NOT DRINK."
- Materials applied as temporary soil stabilizers and soil binders also generally provide wind erosion control benefits.
- Pave or chemically stabilize access points where unpaved traffic surfaces adjoin paved roads.
- Provide covers for haul trucks transporting materials that contribute to dust.
- Provide for wet suppression or chemical stabilization of exposed soils.
- Provide for rapid clean up of sediments deposited on paved roads. Furnish stabilized construction road entrances and vehicle wash down areas.
- Stabilize inactive construction sites using vegetation or chemical stabilization methods.
- Limit the amount of areas disturbed by clearing and earth moving operations by scheduling these activities in phases.

For chemical stabilization, there are many products available for chemically stabilizing gravel roadways and stockpiles. If chemical stabilization is used, the chemicals should not create any adverse effects on stormwater, plant life, or groundwater.

**Costs**

Installation costs for water and chemical dust suppression are low, but annual costs may be quite high since these measures are effective for only a few hours to a few days.

**Inspection and Maintenance**

- Inspect and verify that activity-based BMPs are in place prior to the commencement of associated activities. While activities associated with the BMP are under way, inspect weekly during the rainy season and at two-week intervals in the non-rainy season to verify continued BMP implementation.
- Check areas protected to ensure coverage.
- Most dust control measures require frequent, often daily, or multiple times per day attention.

**References**

Best Management Practices and Erosion Control Manual for Construction Sites, Flood Control District of Maricopa County, Arizona, September 1992.

California Air Pollution Control Laws, California Air Resources Board, 1992.

Caltrans, Standard Specifications, Sections 10, "Dust Control"; Section 17, "Watering"; and Section 18, "Dust Palliative".

Prospects for Attaining the State Ambient Air Quality Standards for Suspended Particulate Matter (PM<sub>10</sub>), Visibility Reducing Particles, Sulfates, Lead, and Hydrogen Sulfide, California Air Resources Board, April 1991.

Stormwater Quality Handbooks Construction Site Best Management Practices (BMPs) Manual, State of California Department of Transportation (Caltrans), November 2000.

# Solid Waste Management

WM-5

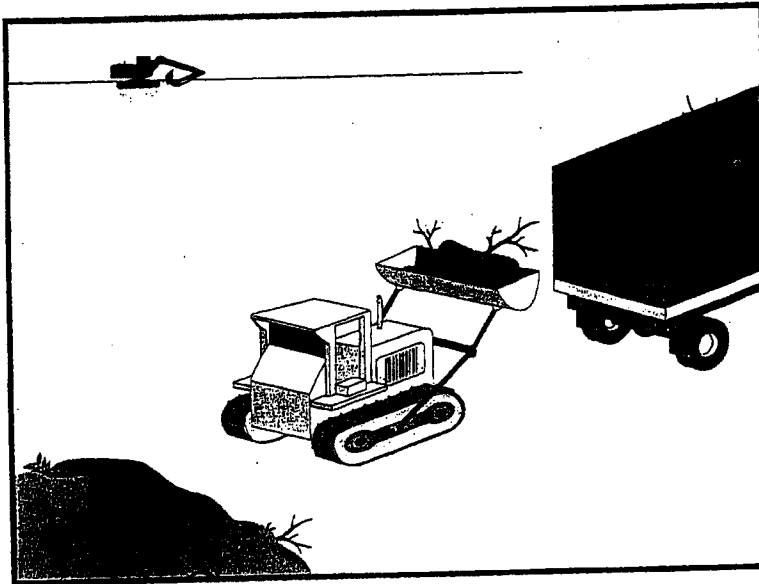

## Objectives

EC	Erosion Control	
SE	Sediment Control	
TC	Tracking Control	
WE	Wind Erosion Control	
NS	Non-Stormwater Management Control	
WM	Waste Management and Materials Pollution Control	✓

## Legend:

- ✓ Primary Objective
- ✓ Secondary Objective

## Description and Purpose

Solid waste management procedures and practices are designed to prevent or reduce the discharge of pollutants to stormwater from solid or construction waste by providing designated waste collection areas and containers, arranging for regular disposal, and training employees and subcontractors.

## Suitable Applications

This BMP is suitable for construction sites where the following wastes are generated or stored:

- Solid waste generated from trees and shrubs removed during land clearing, demolition of existing structures (rubble), and building construction
- Packaging materials including wood, paper, and plastic
- Scrap or surplus building materials including scrap metals, rubber, plastic, glass pieces and masonry products
- Domestic wastes including food containers such as beverage cans, coffee cups, paper bags, plastic wrappers, and cigarettes
- Construction wastes including brick, mortar, timber, steel and metal scraps, pipe and electrical cuttings, non-hazardous equipment parts, styrofoam and other materials used to transport and package construction materials

## Targeted Constituents

Sediment	✓
Nutrients	✓
Trash	✓
Metals	✓
Bacteria	
Oil and Grease	✓
Organics	✓

## Potential Alternatives

None



- Highway planting wastes, including vegetative material, plant containers, and packaging materials

**Limitations**

Temporary stockpiling of certain construction wastes may not necessitate stringent drainage related controls during the non-rainy season or in desert areas with low rainfall.

**Implementation**

The following steps will help keep a clean site and reduce stormwater pollution:

- Select designated waste collection areas onsite.
- Inform trash-hauling contractors that you will accept only watertight dumpsters for onsite use. Inspect dumpsters for leaks and repair any dumpster that is not watertight.
- Locate containers in a covered area or in a secondary containment.
- Provide an adequate number of containers with lids or covers that can be placed over the container to keep rain out or to prevent loss of wastes when it is windy.
- Plan for additional containers and more frequent pickup during the demolition phase of construction.
- Collect site trash daily, especially during rainy and windy conditions.
- Remove this solid waste promptly since erosion and sediment control devices tend to collect litter.
- Make sure that toxic liquid wastes (used oils, solvents, and paints) and chemicals (acids, pesticides, additives, curing compounds) are not disposed of in dumpsters designated for construction debris.
- Do not hose out dumpsters on the construction site. Leave dumpster cleaning to the trash hauling contractor.
- Arrange for regular waste collection before containers overflow.
- Clean up immediately if a container does spill.
- Make sure that construction waste is collected, removed, and disposed of only at authorized disposal areas.

**Education**

- Have the contractor's superintendent or representative oversee and enforce proper solid waste management procedures and practices.
- Instruct employees and subcontractors on identification of solid waste and hazardous waste.
- Educate employees and subcontractors on solid waste storage and disposal procedures.

- Hold regular meetings to discuss and reinforce disposal procedures (incorporate into regular safety meetings).
- Require that employees and subcontractors follow solid waste handling and storage procedures.
- Prohibit littering by employees, subcontractors, and visitors.
- Minimize production of solid waste materials wherever possible.

## ***Collection, Storage, and Disposal***

- Littering on the project site should be prohibited.
- To prevent clogging of the storm drainage system, litter and debris removal from drainage grates, trash racks, and ditch lines should be a priority.
- Trash receptacles should be provided in the contractor's yard, field trailer areas, and at locations where workers congregate for lunch and break periods.
- Litter from work areas within the construction limits of the project site should be collected and placed in watertight dumpsters at least weekly, regardless of whether the litter was generated by the contractor, the public, or others. Collected litter and debris should not be placed in or next to drain inlets, stormwater drainage systems, or watercourses.
- Dumpsters of sufficient size and number should be provided to contain the solid waste generated by the project.
- Full dumpsters should be removed from the project site and the contents should be disposed of by the trash hauling contractor.
- Construction debris and waste should be removed from the site biweekly or more frequently as needed.
- Construction material visible to the public should be stored or stacked in an orderly manner.
- Stormwater runoff should be prevented from contacting stored solid waste through the use of berms, dikes, or other temporary diversion structures or through the use of measures to elevate waste from site surfaces.
- Solid waste storage areas should be located at least 50 ft from drainage facilities and watercourses and should not be located in areas prone to flooding or ponding.
- Except during fair weather, construction and highway planting waste not stored in watertight dumpsters should be securely covered from wind and rain by covering the waste with tarps or plastic.
- Segregate potentially hazardous waste from non-hazardous construction site waste.
- Make sure that toxic liquid wastes (used oils, solvents, and paints) and chemicals (acids, pesticides, additives, curing compounds) are not disposed of in dumpsters designated for construction debris.

- For disposal of hazardous waste, see WM-6, Hazardous Waste Management. Have hazardous waste hauled to an appropriate disposal and/or recycling facility.
- Salvage or recycle useful vegetation debris, packaging and surplus building materials when practical. For example, trees and shrubs from land clearing can be used as a brush barrier, or converted into wood chips, then used as mulch on graded areas. Wood pallets, cardboard boxes, and construction scraps can also be recycled.

**Costs**

All of the above are low cost measures.

**Inspection and Maintenance**

- Inspect and verify that activity-based BMPs are in place prior to the commencement of associated activities. While activities associated with the BMP are under way, inspect weekly during the rainy season and of two-week intervals in the non-rainy season to verify continued BMP implementation.
- Inspect BMPs subject to non-stormwater discharge daily while non-stormwater discharges occur
- Inspect construction waste area regularly.
- Arrange for regular waste collection.

**References**

Processes, Procedures and Methods to Control Pollution Resulting from All Construction Activity, 430/9-73-007, USEPA, 1973.

Stormwater Quality Handbooks - Construction Site Best Management Practices (BMPs) Manual, State of California Department of Transportation (Caltrans), November 2000.

Stormwater Management for Construction Activities; Developing Pollution Prevention Plans and Best Management Practice, EPA 832-R-92005; USEPA, April 1992.



# Hazardous Waste Management

# WM-6

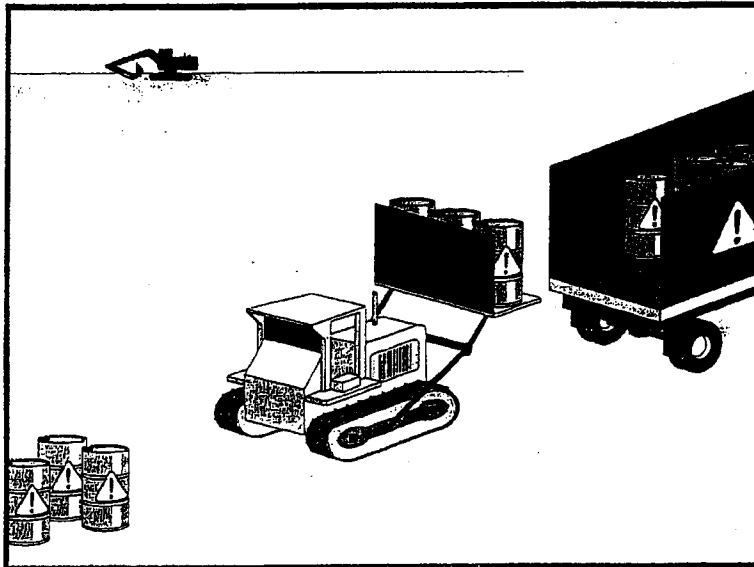

## Objectives

EC	Erosion Control	
SE	Sediment Control	
TC	Tracking Control	
WE	Wind Erosion Control	
NS	Non-Stormwater Management Control	
WM	Waste Management and Materials Pollution Control	✓

## Legend:

- ✓ Primary Objective
- ✓ Secondary Objective

## Description and Purpose

Prevent or reduce the discharge of pollutants to stormwater from hazardous waste through proper material use, waste disposal, and training of employees and subcontractors.

## Suitable Applications

This best management practice (BMP) applies to all construction projects. Hazardous waste management practices are implemented on construction projects that generate waste from the use of:

- Petroleum Products
- Concrete Curing Compounds
- Palliatives
- Septic Wastes
- Stains
- Wood Preservatives
- Asphalt Products
- Pesticides
- Acids
- Paints
- Solvents
- Roofing Tar
- Any materials deemed a hazardous waste in California, Title 22 Division 4.5, or listed in 40 CFR Parts 110, 117, 261, or 302

## Targeted Constituents

Sediment	
Nutrients	✓
Trash	✓
Metals	✓
Bacteria	✓
Oil and Grease	✓
Organics	✓

## Potential Alternatives

None





In addition, sites with existing structures may contain wastes, which must be disposed of in accordance with federal, state, and local regulations. These wastes include:

- Sandblasting grit mixed with lead-, cadmium-, or chromium-based paints
- Asbestos
- PCBs (particularly in older transformers)

## Limitations

- Hazardous waste that cannot be reused or recycled must be disposed of by a licensed hazardous waste hauler.
- Nothing in this BMP relieves the contractor from responsibility for compliance with federal, state, and local laws regarding storage, handling, transportation, and disposal of hazardous wastes.
- This BMP does not cover aerially deposited lead (ADL) soils. For ADL soils refer to WM-7, Contaminated Soil Management.

## Implementation

The following steps will help reduce stormwater pollution from hazardous wastes:

### *Material Use*

- Wastes should be stored in sealed containers constructed of a suitable material and should be labeled as required by Title 22 CCR, Division 4.5 and 49 CFR Parts 172, 173, 178, and 179.
- All hazardous waste should be stored, transported, and disposed as required in Title 22 CCR, Division 4.5 and 49 CFR 261-263.
- Waste containers should be stored in temporary containment facilities that should comply with the following requirements:
  - Temporary containment facility should provide for a spill containment volume equal to 1.5 times the volume of all containers able to contain precipitation from a 25 year storm event, plus the greater of 10% of the aggregate volume of all containers or 100% of the capacity of the largest tank within its boundary, whichever is greater.
  - Temporary containment facility should be impervious to the materials stored there for a minimum contact time of 72 hours.
  - Temporary containment facilities should be maintained free of accumulated rainwater and spills. In the event of spills or leaks, accumulated rainwater and spills should be placed into drums after each rainfall. These liquids should be handled as a hazardous waste unless testing determines them to be non-hazardous. Non-hazardous liquids should be sent to an approved disposal site.
  - Sufficient separation should be provided between stored containers to allow for spill cleanup and emergency response access.

- Incompatible materials, such as chlorine and ammonia, should not be stored in the same temporary containment facility.
- Throughout the rainy season, temporary containment facilities should be covered during non-working days, and prior to rain events. Covered facilities may include use of plastic tarps for small facilities or constructed roofs with overhangs.
- Drums should not be overfilled and wastes should not be mixed.
- Unless watertight, containers of dry waste should be stored on pallets.
- Do not over-apply herbicides and pesticides. Prepare only the amount needed. Follow the recommended usage instructions. Over application is expensive and environmentally harmful. Apply surface dressings in several smaller applications, as opposed to one large application. Allow time for infiltration and avoid excess material being carried offsite by runoff. Do not apply these chemicals just before it rains. People applying pesticides must be certified in accordance with federal and state regulations.
- Paint brushes and equipment for water and oil based paints should be cleaned within a contained area and should not be allowed to contaminate site soils, watercourses, or drainage systems. Waste paints, thinners, solvents, residues, and sludges that cannot be recycled or reused should be disposed of as hazardous waste. When thoroughly dry, latex paint and paint cans, used brushes, rags, absorbent materials, and drop cloths should be disposed of as solid waste.
- Do not clean out brushes or rinse paint containers into the dirt, street, gutter, storm drain, or stream. "Paint out" brushes as much as possible. Rinse water-based paints to the sanitary sewer. Filter and reuse thinners and solvents. Dispose of excess oil-based paints and sludge as hazardous waste.
- The following actions should be taken with respect to temporary contaminant:
  - Ensure that adequate hazardous waste storage volume is available.
  - Ensure that hazardous waste collection containers are conveniently located.
  - Designate hazardous waste storage areas onsite away from storm drains or watercourses and away from moving vehicles and equipment to prevent accidental spills.
  - Minimize production or generation of hazardous materials and hazardous waste on the job site.
  - Use containment berms in fueling and maintenance areas and where the potential for spills is high.
  - Segregate potentially hazardous waste from non-hazardous construction site debris.
  - Keep liquid or semi-liquid hazardous waste in appropriate containers (closed drums or similar) and under cover.

- Clearly label all hazardous waste containers with the waste being stored and the date of accumulation.
- Place hazardous waste containers in secondary containment.
- Do not allow potentially hazardous waste materials to accumulate on the ground.
- Do not mix wastes.
- Use all of the product before disposing of the container.
- Do not remove the original product label; it contains important safety and disposal information.

### ***Waste Recycling Disposal***

- Select designated hazardous waste collection areas onsite.
- Hazardous materials and wastes should be stored in covered containers and protected from vandalism.
- Place hazardous waste containers in secondary containment.
- Do not mix wastes, this can cause chemical reactions, making recycling impossible and complicating disposal.
- Recycle any useful materials such as used oil or water-based paint.
- Make sure that toxic liquid wastes (used oils, solvents, and paints) and chemicals (acids, pesticides, additives, curing compounds) are not disposed of in dumpsters designated for construction debris.
- Arrange for regular waste collection before containers overflow.
- Make sure that hazardous waste (e.g., excess oil-based paint and sludge) is collected, removed, and disposed of only at authorized disposal areas.

### ***Disposal Procedures***

- Waste should be disposed of by a licensed hazardous waste transporter at an authorized and licensed disposal facility or recycling facility utilizing properly completed Uniform Hazardous Waste Manifest forms.
- A Department of Health Services certified laboratory should sample waste to determine the appropriate disposal facility.
- Properly dispose of rainwater in secondary containment that may have mixed with hazardous waste.
- Attention is directed to "Hazardous Material", "Contaminated Material", and "Aerially Deposited Lead" of the contract documents regarding the handling and disposal of hazardous materials.

## ***Education***

- Educate employees and subcontractors on hazardous waste storage and disposal procedures.
- Educate employees and subcontractors on potential dangers to humans and the environment from hazardous wastes.
- Instruct employees and subcontractors on safety procedures for common construction site hazardous wastes.
- Instruct employees and subcontractors in identification of hazardous and solid waste.
- Hold regular meetings to discuss and reinforce hazardous waste management procedures (incorporate into regular safety meetings).
- The contractor's superintendent or representative should oversee and enforce proper hazardous waste management procedures and practices.
- Make sure that hazardous waste is collected, removed, and disposed of only at authorized disposal areas.
- Warning signs should be placed in areas recently treated with chemicals.
- Place a stockpile of spill cleanup materials where it will be readily accessible.
- If a container does spill, clean up immediately.

## **Costs**

All of the above are low cost measures.

## ***Inspection and Maintenance***

- Inspect and verify that activity-based BMPs are in place prior to the commencement of associated activities. While activities associated with the BMP are under way, inspect weekly during the rainy season and of two week intervals in the non-rainy season to verify continued BMP implementation.
- Inspect BMPs subject to non-stormwater discharge daily while non-stormwater discharges occur
- Hazardous waste should be regularly collected.
- A foreman or construction supervisor should monitor onsite hazardous waste storage and disposal procedures.
- Waste storage areas should be kept clean, well organized, and equipped with ample cleanup supplies as appropriate for the materials being stored.
- Perimeter controls, containment structures, covers, and liners should be repaired or replaced as needed to maintain proper function.
- Hazardous spills should be cleaned up and reported in conformance with the applicable Material Safety Data Sheet (MSDS) and the instructions posted at the project site.

- The National Response Center, at (800) 424-8802, should be notified of spills of federal reportable quantities in conformance with the requirements in 40 CFR parts 110, 117, and 302. Also notify the Governors Office of Emergency Services Warning Center at (916) 845-8911.
- A copy of the hazardous waste manifests should be provided.

## **References**

Blueprint for a Clean Bay: Best Management Practices to Prevent Stormwater Pollution from Construction Related Activities; Santa Clara Valley Nonpoint Source Pollution Control Program, 1995.

Processes, Procedures and Methods to Control Pollution Resulting from All Construction Activity, 430/9-73-007, USEPA, 1973.

Stormwater Quality Handbooks - Construction Site Best Management Practices (BMPs) Manual, State of California Department of Transportation (Caltrans), November 2000.

Stormwater Management for Construction Activities; Developing Pollution Prevention Plans and Best Management Practice, EPA 832-R-92005; USEPA, April 1992.

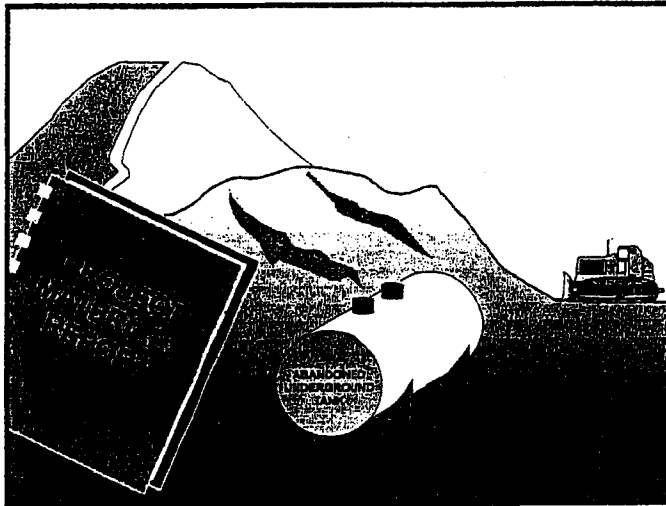

## Description and Purpose

Prevent or reduce the discharge of pollutants to stormwater from contaminated soil and highly acidic or alkaline soils by conducting pre-construction surveys, inspecting excavations regularly, and remediating contaminated soil promptly.

## Suitable Applications

Contaminated soil management is implemented on construction projects in highly urbanized or industrial areas where soil contamination may have occurred due to spills, illicit discharges, aerial deposition, past use and leaks from underground storage tanks.

## Limitations

Contaminated soils that cannot be treated onsite must be disposed of offsite by a licensed hazardous waste hauler. The presence of contaminated soil may indicate contaminated water as well. See NS-2, Dewatering Operations, for more information.

The procedures and practices presented in this BMP are general. The contractor should identify appropriate practices and procedures for the specific contaminants known to exist or discovered onsite.

## Implementation

Most owners and developers conduct pre-construction environmental assessments as a matter of routine. Contaminated soils are often identified during project planning and development with known locations identified in the plans, specifications and in the SWPPP. The contractor should review applicable reports and investigate appropriate call-outs in the plans, specifications, and

## Objectives

EC	Erosion Control	
SE	Sediment Control	
TC	Tracking Control	
WE	Wind Erosion Control	
NS	Non-Stormwater Management Control	
WM	Waste Management and Materials Pollution Control	✓

## Legend:

- ✓ Primary Objective
- ✓ Secondary Objective

## Targeted Constituents

Sediment	
Nutrients	✓
Trash	✓
Metals	✓
Bacteria	✓
Oil and Grease	✓
Organics	✓

## Potential Alternatives

None





SWPPP. Recent court rulings holding contractors liable for cleanup costs when they unknowingly move contaminated soil highlight the need for contractors to confirm a site assessment is completed before earth moving begins.

The following steps will help reduce stormwater pollution from contaminated soil:

- Conduct thorough, pre-construction inspections of the site and review documents related to the site. If inspection or reviews indicated presence of contaminated soils, develop a plan before starting work.
- Look for contaminated soil as evidenced by discoloration, odors, differences in soil properties, abandoned underground tanks or pipes, or buried debris.
- Prevent leaks and spills. Contaminated soil can be expensive to treat and dispose of properly. However, addressing the problem before construction is much less expensive than after the structures are in place.
- The contractor may further identify contaminated soils by investigating:
  - Past site uses and activities
  - Detected or undetected spills and leaks
  - Acid or alkaline solutions from exposed soil or rock formations high in acid or alkaline forming elements
  - Contaminated soil as evidenced by discoloration, odors, differences in soil properties, abandoned underground tanks or pipes, or buried debris.
  - Suspected soils should be tested at a certified laboratory.

### ***Education***

- Have employees and subcontractors complete a safety training program which meets 29 CFR 1910.120 and 8 CCR 5192 covering the potential hazards as identified, prior to performing any excavation work at the locations containing material classified as hazardous.
- Educate employees and subcontractors in identification of contaminated soil and on contaminated soil handling and disposal procedures.
- Hold regular meetings to discuss and reinforce disposal procedures (incorporate into regular safety meetings).

### ***Handling Procedures for Material with Aerially Deposited Lead (ADL)***

- Materials from areas designated as containing (ADL) may, if allowed by the contract special provisions, be excavated, transported, and used in the construction of embankments and/or backfill.
- Excavation, transportation, and placement operations should result in no visible dust.
- Caution should be exercised to prevent spillage of lead containing material during transport.

- Quality should be monitored during excavation of soils contaminated with lead.

### ***Handling Procedures for Contaminated Soils***

- Minimize onsite storage. Contaminated soil should be disposed of properly in accordance with all applicable regulations. All hazardous waste storage will comply with the requirements in Title 22, CCR, Sections 66265.250 to 66265.260.
- Test suspected soils at an approved certified laboratory.
- Work with the local regulatory agencies to develop options for treatment or disposal if the soil is contaminated.
- Avoid temporary stockpiling of contaminated soils or hazardous material.
- Take the following precautions if temporary stockpiling is necessary:
  - Cover the stockpile with plastic sheeting or tarps.
  - Install a berm around the stockpile to prevent runoff from leaving the area.
  - Do not stockpile in or near storm drains or watercourses.
- Remove contaminated material and hazardous material on exteriors of transport vehicles and place either into the current transport vehicle or into the excavation prior to the vehicle leaving the exclusion zone.
- Monitor the air quality continuously during excavation operations at all locations containing hazardous material.
- Procure all permits and licenses, pay all charges and fees, and give all notices necessary and incident to the due and lawful prosecution of the work, including registration for transporting vehicles carrying the contaminated material and the hazardous material.
- Collect water from decontamination procedures and treat or dispose of it at an appropriate disposal site.
- Collect non-reusable protective equipment, once used by any personnel, and dispose of at an appropriate disposal site.
- Install temporary security fence to surround and secure the exclusion zone. Remove fencing when no longer needed.
- Excavate, transport, and dispose of contaminated material and hazardous material in accordance with the rules and regulations of the following agencies (the specifications of these agencies supersede the procedures outlined in this BMP):
  - United States Department of Transportation (USDOT)
  - United States Environmental Protection Agency (USEPA)
  - California Environmental Protection Agency (CAL-EPA)

- California Division of Occupation Safety and Health Administration (CAL-OSHA)
- Local regulatory agencies

### ***Procedures for Underground Storage Tank Removals***

- Prior to commencing tank removal operations, obtain the required underground storage tank removal permits and approval from the federal, state, and local agencies that have jurisdiction over such work.
- To determine if it contains hazardous substances, arrange to have tested, any liquid or sludge found in the underground tank prior to its removal.
- Following the tank removal, take soil samples beneath the excavated tank and perform analysis as required by the local agency representative(s).
- The underground storage tank, any liquid or sludge found within the tank, and all contaminated substances and hazardous substances removed during the tank removal and transported to disposal facilities permitted to accept such waste.

### ***Water Control***

- All necessary precautions and preventive measures should be taken to prevent the flow of water, including ground water, from mixing with hazardous substances or underground storage tank excavations. Such preventative measures may consist of, but are not limited to, berms, cofferdams, grout curtains, freeze walls, and seal course concrete or any combination thereof.
- If water does enter an excavation and becomes contaminated, such water, when necessary to proceed with the work, should be discharged to clean, closed top, watertight transportable holding tanks, treated, and disposed of in accordance with federal, state, and local laws.

### ***Costs***

Prevention of leaks and spills is inexpensive. Treatment or disposal of contaminated soil can be quite expensive.

### ***Inspection and Maintenance***

- Inspect and verify that activity-based BMPs are in place prior to the commencement of associated activities. While activities associated with the BMP are under way, inspect weekly during the rainy season and of two-week intervals in the non-rainy season to verify continued BMP implementation.
- Arrange for contractor's Water Pollution Control Manager, foreman, and/or construction supervisor to monitor onsite contaminated soil storage and disposal procedures.
- Monitor air quality continuously during excavation operations at all locations containing hazardous material.
- Coordinate contaminated soils and hazardous substances/waste management with the appropriate federal, state, and local agencies.

# **Contaminated Soil Management**

**WM-7**

- Implement WM-4, Spill Prevention and Control, to prevent leaks and spills as much as possible.

## **References**

Blueprint for a Clean Bay: Best Management Practices to Prevent Stormwater Pollution from Construction Related Activities; Santa Clara Valley Nonpoint Source Pollution Control Program, 1995.

Processes, Procedures and Methods to Control Pollution Resulting from All Construction Activity, 430/9-73-007, USEPA, 1973.

Stormwater Quality Handbooks - Construction Site Best Management Practices (BMPs) Manual, State of California Department of Transportation (Caltrans), November 2000.

Stormwater Management for Construction Activities; Developing Pollution Prevention Plans and Best Management Practice, EPA 832-R-92005; USEPA, April 1992.