



WINDER TREADS AND SPIRAL STAIRWAYS

Winder treads are not permitted in means of egress stairways except within a dwelling unit. Exceptions to this include curved stairways and spiral stairways designed in accordance with Sections 1009.8 and 1009.9, respectively.

The following details apply to winder treads in Group R-3, R-3.1 and R-4 occupancies, within dwelling units in Group R-2 occupancies, and in Group U occupancies that are accessory to Group R-3, R-3.1 or R-4 occupancy or accessory to individual dwelling units in Group R-2 occupancies. The plans must show minimum dimensions for winder treads used in stairways. Plan or section views must indicate the following:

- The maximum riser height shall be 7.75 inches
- Treads must have a minimum width of 6 inches and the required 10 inch width within 12 inches of the narrower end.
- A nosing not less than 0.75 inch but not more than 1.25 inches shall be provided on stairways with solid risers where the tread depth is less than 11 inches.
- Stairway width shall not be less than 36 inches.

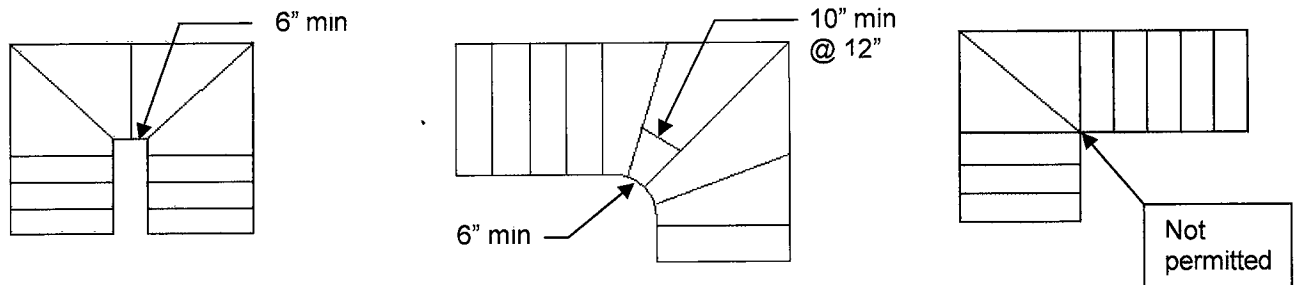

Curved stairways with winder treads must meet the minimum and maximum tread and riser requirements per Section 1009.4. Specifically, a minimum 11 inch tread depth, measured at a right angle to the tread's leading edge at a point 12 inches in from the side where the treads are narrower, is required, a minimum tread depth of 10 inches is required, and riser heights shall be 4 inches minimum and 7 inches maximum. Also, the smallest radius of the stair shall not be less than twice the required width of the stairway (radius requirements need not be met within Group R-3 occupancy or an individual dwelling unit within Group R-2 occupancy).

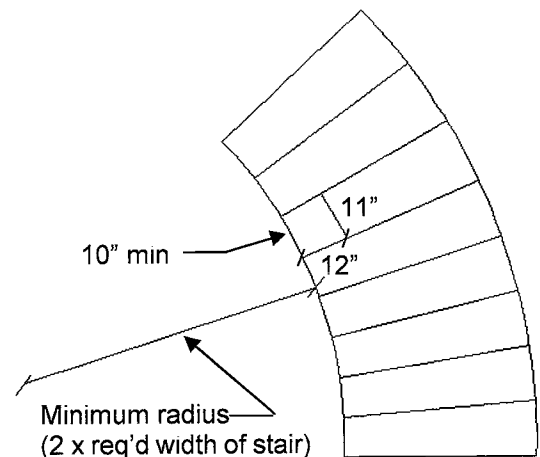

Spiral stairways may be used as a means of egress element only in the following applications:

- Within dwelling units.
- In Group I-3 occupancies for access to and between staff locations (Section 408.3.4)
- In all other occupancies from a space not more than 250 square feet in area and serving five (5) or less occupants.
- From galleries, catwalks, and gridirons (see Section 410) in accordance with Section 1015.6.

Spiral stairways must have a 7.5 inch minimum clear tread depth at a point 12 inches from the narrow edge. Riser heights are required to be the same and are not to exceed 9.5 inches. Minimum headroom of 6 foot 6 inches is required. The minimum stairway width shall be 26 inches.

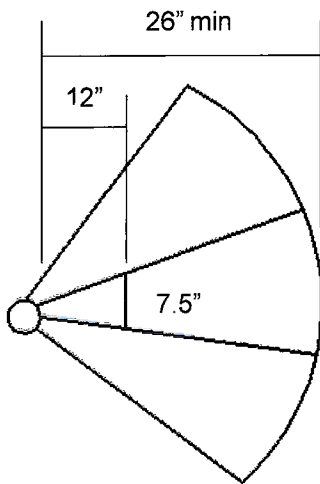

Supersedes BCM 1009.3.1, Article 1 dated 07-01-0-9 and BCM 33 07 dated 06/22/88

WRITTEN BY. CIARA BARNETT
Civil Engineer

REVIEWED BY JUAN MADRIGAL
Senior Civil Engineer

RECOMMENDED BY

APPROVED BY:

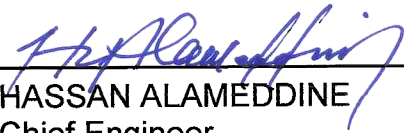
HASSAN ALAMEDDINE
Chief Engineer

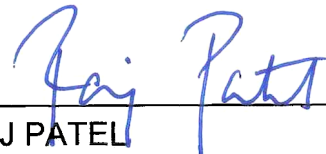
RAJ PATEL
Superintendent of Building