

**WATER  
SURFACE  
PRESSURE  
GRADIENT  
HYDRAULIC  
ANALYSIS  
COMPUTER  
PROGRAM  
FO515P  
USER MANUAL**



**APRIL 1979**

COMPUTER PROGRAM F0515P

W S P G

Water Surface and Pressure Gradient

Hydraulic Analysis System

USER MANUAL

April 1979

Los Angeles County Flood Control District  
A. E. Bruington, Chief Engineer

2250 Alcazar Street, Los Angeles  
Telephone: (213) 226-4111

P.O. Box 2418 Terminal Annex  
Los Angeles, CA 90054

W S P G

Water Surface and Pressure Gradient

Hydraulic Analysis System

USER MANUAL

Prepared By: Saman J. Shahin,  
Garvin J. Pederson  
Design Systems & Standards Group  
Design Division

and

Richard A. Schaeffer  
Business and Fiscal Division

April 1979

## FORWARD

This program was written for use by the Los Angeles County Flood Control District or by its Contractors on District projects.

The use of this program by others is made and accepted with the understanding the Los Angeles County Flood Control District makes no warranties, express or implied, concerning its accuracy, completeness, reliability, usability or suitability and the District shall be under no liability for any use made thereof.

This program is the property of the District. Therefore, a recipient further agrees not to assert any proprietary rights to this program or modification of or to represent it to anyone as other than a District program.

## ACKNOWLEDGMENTS

Special thanks to Design Division Stenographers Deborah Mount and Rita Lopez for their patience and skill in typing this report. Thanks also to Eddie Nishiyama and Roy Fujimoto for preparing the drawings.

## TABLE OF CONTENTS

<u>SECTION</u>	<u>Page</u>
1. Introduction	1
2. Purpose of Program	1
3. General Program Description	1
3.2 Basic Theory	1
3.3 Computational Procedure	1
3.3.1 Input Preparation	1
3.3.2 Flow Rates	2
3.3.3 Multiple Profiles	2
3.3.4 Manning's "n"	2
3.3.5 Water Surface Controls	2
3.3.6 Critical and Normal Depths	2
3.3.7 Water Surface Stages	3
4. Data Processing System Description	4
5. Element Description	5
5.1.1 Boundary Lines	5
5.1.2 System Outlet (SO)	5
5.1.3 System Headworks (SH)	5
5.1.4 Reach (R)	5
5.1.5 Junction Structure (JX)	6
5.1.6 Transition Structure (TS)	6
5.1.7 Bridge Entrance (BE)	6
5.1.8 Bridge Exit (BX)	6
5.1.9 Wall Entrance (WE)	7
5.1.10 Wall Exit (WX)	7

Table of Contents  
Continued.

<u>SECTION</u>	<u>PAGE</u>
6. Channel and Conduit Section Description -----	14
6.1.1 Regular Channel Sections -----	14
6.1.2 Irregular Sections -----	14
6.1.3 Definitions and Restrictions for Irregular Sections -----	15
7. Input Data Description -----	18
7.1.1 Title Cards (T) -----	19
7.1.2 Element Cards -----	21
System Outlet (SO) -----	22
Reach (R), Channel Type 1, 2, or 5 -----	23
Reach (R), Channel Type 3, 4, or 6 -----	24
Transition Structure (TS) -----	25
Junction Structure (JX) -----	26
Bridge Entrance (BE) -----	27
Bridge Exit (BX) -----	28
Wall Entrance (WE) -----	29
Wall Exit (WX) -----	30
System Headworks (SH) -----	31
7.1.3 Channel Definition Cards -----	32
(CD) Cards, Regular -----	33
(CD) Cards, Irregular -----	34
7.1.4 PTS Card, x and y Coordinates -----	35
(PTS) Card -----	36

Table of Contents  
Continued.

<u>SECTION</u>	<u>PAGE</u>
7.1.5 Q Cards	38
7.1.6 Control Cards	40
7.2 Sample Input	41
8. Output Data Description	50
8.1.1 Normal Output	50
8.1.2 Optional Output	50
8.1.3 Sample Output	51
9. Error Messages	70
9.1.1 Error Messages in Editing the Element Cards	71
9.1.2 Warning Messages in Editing the Element Cards	73
9.1.3 Error Messages in Sequence Checking thru Channel Definition Data	74
9.1.4 Error Messages in Sequence Checking Cross Section Points Cards	76
9.1.5 Error Messages in Channel Definition Processing	78
9.1.6 Error Messages in Cross Section Point Processing	79
9.1.7 Computation Error and Warning Messages	80
9.1.8 Debug Message	87
10. System Recovery Procedure	88
11. Limitations	89
12. Appendix	90

## 1.1 Introduction

This program is a hydraulic analysis system developed by the Design Systems and Standards Group of the Design Division and the Data Processing Section of the Business and Fiscal Division of the Los Angeles County Flood Control District.

## 2.1 Purpose

The program computes and plots uniform and nonuniform steady flow water surface profiles and pressure gradients in open channels or closed conduits with irregular or regular sections. The flow in a system may alternate between super critical, subcritical or pressure flow in any sequence. The program will also analyze natural river channels although the principle use of the program is intended for determining profiles in improved flood control systems.

## 3.1 General Program Description

### 3.2 Basic Theory

The computational procedure is based on solving Bernoulli's equation for the total energy at each section and Manning's formula for friction loss between the sections in a reach. The open channel flow procedure utilizes the standard step method. Confluences and bridge piers are analyzed using pressure and momentum theory.

The program uses basic mathematical and hydraulic principles to calculate all such data as cross sectional area, wetted perimeter, normal depth, critical depth, pressure, and momentum.

### 3.3 Computational Procedure

#### 3.3.1 Input Preparation

The channel or conduit system is initially subdivided into the following elements: system outlet, reach, transition, confluence (junction), bridge exit, bridge entrance, wall entrance (sudden contraction), wall exit (sudden expansion), and system headworks. Each element is internally assigned a number. The input data must consist of a minimum of three elements (system outlet, system headwork and any other element) and is limited to a maximum of 200 elements. A greater number of elements will require a breakup into two or more systems.



### 3.3.2 Flow Rates

The starting flow rate (Q) at the upstream terminus of a system is specified on a "Q" card. The flow rate (Q) is increased at the desired locations by specifying lateral inflow rates on the "JX" cards. The flow rate can be reduced by using a negative lateral Q, this reduction is intended to account for channel storage. If it is used in cases where the channel or conduit branches it should be understood no loss is computed.

### 3.3.3 Multiple Profiles

To obtain additional watersurface or pressure gradient profiles for different flow rates in the system, additional Q cards may be supplied. The only limitation on the number of profiles that may be run at one time is the limit on the program execution time which is set by the computer center.

### 3.3.4 Manning's "n"

The program uses the Manning formula for the friction loss in all types of conduits or natural channels. The program can only take one "n" value per element, however, the "n" value can change at subsequent elements. If a section has a lining composed of different roughness coefficients a composite "n" based on anticipated depth of flow should be hand computed. If an "n" value is not specified with the input data, the program uses a value of .014.

### 3.3.5 Water Surface Controls

Water surface controls at the downstream terminus (System Outlet S.O.) or the upstream terminus (System Headworks S.H.) are optional input values. If water-surface controls are not given the program will use critical depth controls.

### 3.3.6 Critical and Normal Depths

Critical depth is computed for every section for the given Q utilizing the "Specific Energy Equation".

Normal depth is computed in every reach element on a positive slope for the specified Q.

The velocity head ( $H_v$ ) is computed using the mean velocity of the section. This may not be accurate in the case of a complex section such as one with shallow flow in the horizontal overbank area where velocity distribution is not uniform. If the program is to be used in this situation, the user should be aware that some error may be introduced in the results. A check on the magnitude of the error can be made by the user utilizing the parabolic method to determine specific energy (see Appendix).

### 3.3.7 Watersurface Stages

The lower stage w.s. profile begins at the system headworks and ends at the system outlet. The computation will proceed downstream in every consecutive element as long as energy is available to maintain flow in the supercritical stage. When energy becomes expended at any point in an element, the lower stage profile will be discontinued from that point to the downstream end of that element. Then computation will resume in the next element with a critical depth control until the system outlet is analyzed.

The upper stage w.s. profile, begins at the system outlet, and ends at the headworks. Computation proceeds upstream in every element as long as the water surface at the downstream end of any two adjacent points can support the moving mass of water to flow at the critical or subcritical depth. Otherwise, computation will be discontinued from the downstream point to the upstream end of that element. Then computation will resume at the downstream end of the next element with critical depth control, provided no depth less than critical depth has been computed at that point on the lower stage profile. Then computation will proceed upstream until the system headworks is analyzed. Note that if the computed depth of flow in any open section exceeds the given section height the program will assume an additional 10-feet of vertical wall except for Channel Type 1 (see Figure 6-1) where the side slopes are extended outward until the 10-foot vertical height is reached.

The jump routine begins at the system outlet and ends at the headworks. It searches the lower stage and the upper stage profiles for points of equal energy. If a jump is encountered, it will be approximately located; and data on either the upper stage or lower stage not consistent with the greater energy theory will be deleted from every element. The final profile will be a composite of upper stage and lower stage with hydraulic jumps in between.

#### 4.1 Data Processing System Description

All programs are written in FORTRAN IV, compiled using the IBM FORTRAN H compiler executing on an IBM 370/158 using OS/VS2 MVS. The system requires the use of an input media (such as a card reader), temporary disk storage, and a printer. It is designed to run in batch mode.

Required input to the system consists of:

1. Title information.
2. Channel element definitions.
3. Cross section definition.
4. Cross section points definition.
5. Q card, of which the first is required and the subsequent Q cards are optional for change of flow rate in the system.

The entire input is thoroughly scanned for required information and range values of optional information before processing begins. If any errors are detected, processing will stop. Warnings may be issued, but they will not prevent processing.

Processing consists of three phases: Analysis of the system in the downstream direction (phase I), analysis of the system in the upstream direction (Phase II), and analysis of the downstream profile (from Phase I) and the upstream profile (from Phase II) to obtain a composite profile (Phase III). The processing was designed to continue calculating unless gross errors are encountered. Warning messages may be issued concerning tolerance levels not being reached on an iterative approximation. These may or may not effect the overall solution to the problem; however, processing continues. If gross errors are encountered, an error message will be issued and processing will stop.

Output of the system consists of three reports:

1. A listing of input with edit scanning messages.
2. A w.s. profile listing of the composite profile obtained in Phase III of processing.
3. A profile plot of watersurface and channel geometry.

## 5.1 Element Description

The channel, conduit or natural river system to be analyzed is subdivided into elements as stated in Section 3.3.1. The program internally numbers the elements beginning with the System Outlet (SO) as number 1. Each successive element is numbered continuing upstream to the System Headworks (SH). The maximum number of elements permissible by the program is 200.

### 5.1.1 Boundary Lines (Refer to Figure 5-1)

All elements are bounded on the upstream end by Section 1 and the downstream end by Section 2 except System Outlet (SO) and System Headworks (SH) which only have Section 1. The user inputs data such as base width, conduit height, etc. for Section 1 of every element. The data for Section 2 for every element is taken by the program from the upstream Section 1 of the adjacent downstream element. Elements may have considerable length between Section 1 and Section 2 as in a reach element or may have a zero length as in a bridge entrance element.

$L$  = length of element

$X$  = number of the element under consideration

$X+1$  = adjacent upstream element

$X-1$  = adjacent downstream element

### 5.1.2 System Outlet (SO) (Refer to Figure 5-2)

The system outlet is the downstream terminus of a channel.  $X$  is equal to one.  $X+1$  can be any element except a System Headworks (SH). Note the element length is zero.

### 5.1.3 System Headworks (SH) (Refer to Figure 5-3)

The system headworks is the upstream terminus of a channel. Element  $X-1$  can be any element except a system outlet. Note the element length is zero.

### 5.1.4 Reach (R) (Refer to Figure 5-4)

The reach element is a length of channel, drain or natural river with a constant invert slope,  $Q$ , cross section and Manning's  $n$ . A reach may have a straight or curving horizontal alignment, however, a curved reach must coincide with the beginning and end of the curve. The same applies to an angle point in the horizontal alignment, a reach must end or begin at the angle point.

In open channels (regular rectangular or trapezoidal sections) the superelevation of the watersurface is computed and printed for each point in the curve. In pressure flow, bend losses, angle point losses, and manhole losses are computed and added to the friction loss for the reach.

Element X+1 can be any element except a system outlet.  
Element X-1 can be any element except a system headworks.

#### 5.1.5 Junction Structure (JX) (Refer to Figure 5-5)

The junction structure element is used where there is lateral inflow into the system. Two different laterals can be handled by this element. Element X-1 can be any other element except a System Headworks (SH). Element X+1 can be any other element except a System Outlet (SO).

#### 5.1.6 Transition Structure (TS) Refer to Figure 5-6

A transition structure is a gradual expansion or contraction from Section 1 to section 2. The length L may be any positive number. Element X+1 may be any element except a system outlet. (SO) Element X-1 may be any element except a system headworks (SH).

#### 5.1.7 Bridge Entrance (BE) (Refer to Figure 5-7)

A bridge entrance is an element used where flow enters from an element without piers into an element with piers.

A bridge entrance is considered to have a zero length element even though the bridge pier nose may have a minor length.

Element X-1 may be a SO, R, JX or TS.  
Element X+1 may be a R, JX, TS or SH.  
It is noted that neither section 1 or 2 can be a pipe.

#### 5.1.8 Bridge Exit (BX) (Refer to Figure 5-8)

The bridge exit is also considered to have a zero length element.

A bridge exit is an element used where flow exits from an element with piers into an element without piers.

Element X-1 may be a SO, R, JX, or TS.  
Element X+1 may be a SH, R, JX, or TS.  
It is noted that neither section 1 or 2 can be a pipe.

5.1.9 Wall Entrance (WE) (Refer to Figure 5-9)

This element is used when there is a sudden change in the conduit section such as a headwall or an abrupt contraction. This element is considered to have a zero length.

The user should supply the loss coefficient  $K_c$  expressed in terms of the velocity head. If left blank on the input card the program uses a value of .5 for  $K_c$ . (See Hydraulic Handbooks for typical values).

Element X-1 may be a SO, R, JX, or TS.

Element X+1 may be a SH, R, JX, or TS.

The section for element X+1 cannot have piers, however, it can be an open channel or closed conduit. The section for element X-1 can also be an open channel or closed conduit and it can be with or without piers.

5.1.10 Wall Exit (WX) (Refer to Figure 5.10)

This element is used when there is a sudden expansion from a smaller to a larger channel or conduit section. This element is considered to have a zero length.

Element X-1 may be a SO, R, JX or TS.

Element X+1 may be a SH, R, JX or TS.

The section for element X+1 may be an open channel or closed conduit with or without piers. The section for element X-1 may be an open channel or closed conduit however it cannot have piers.

# ELEMENT BOUNDARY LINES

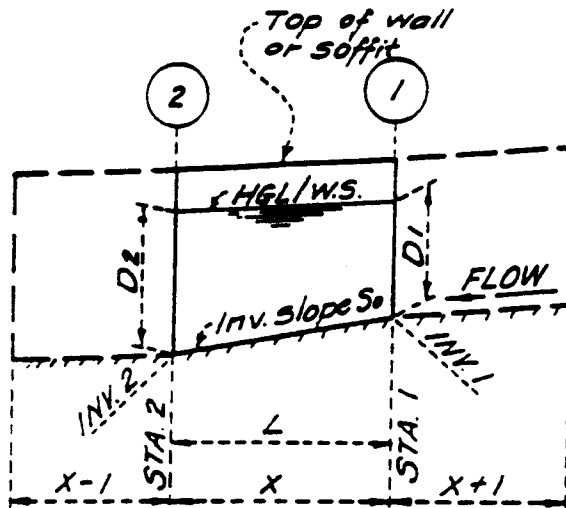

ELEVATION

FIG. 5-1

# SYSTEM OUTLET

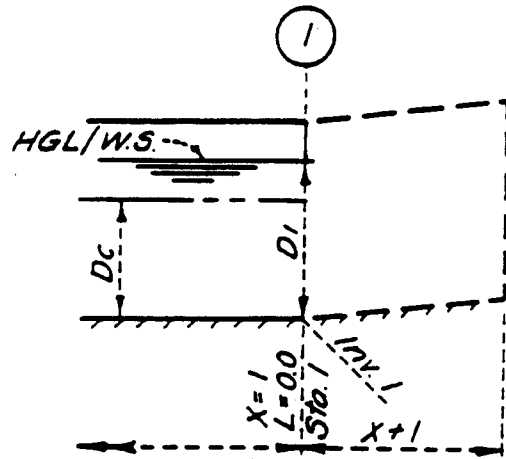

## ELEVATION

FIG. 5-2

# SYSTEM HEADWORKS

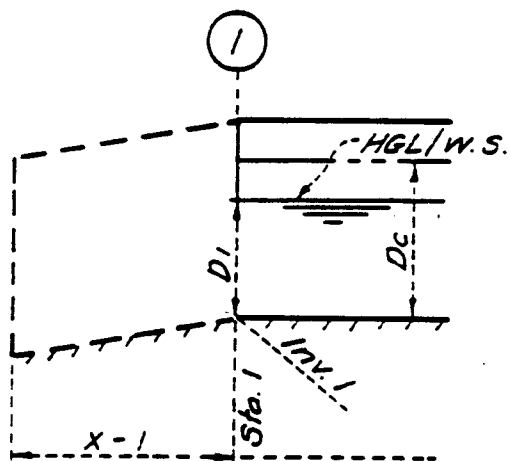

## ELEVATION

FIG. 5-3



# REACH

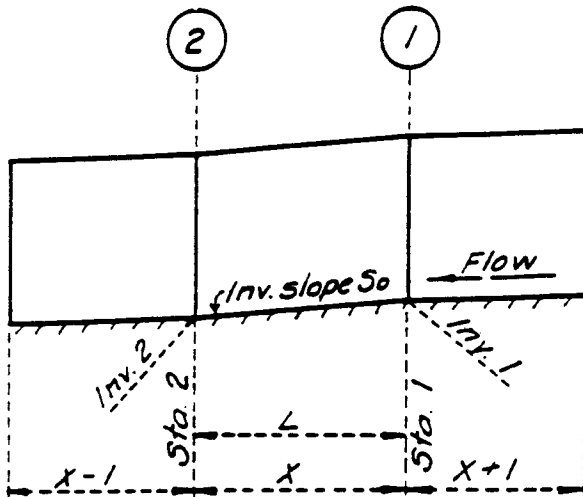

# ELEVATION

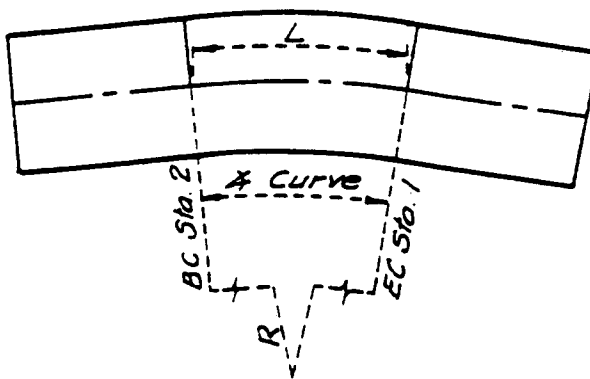

# PLAN A

(EXAMPLE OF CURVED ALIGNMENT)

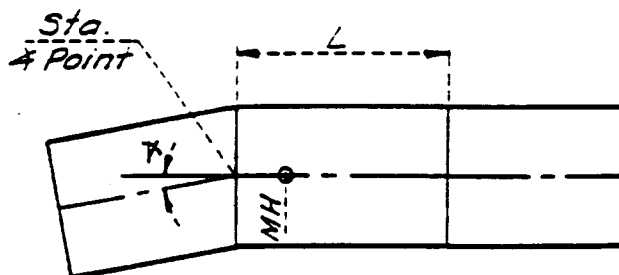

# PLAN B

(EXAMPLE OF A STRAIGHT REACH WITH  $\Delta$  PT. AT D/S END)

FIG. 5-4

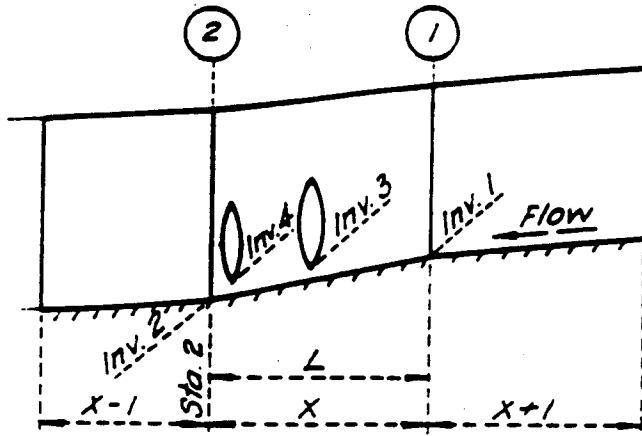

**ELEVATION**

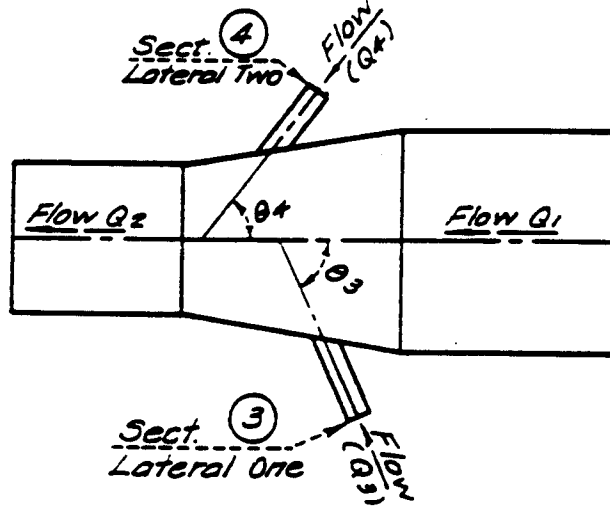

**PLAN**

**JUNCTION**

FIG. 5-5

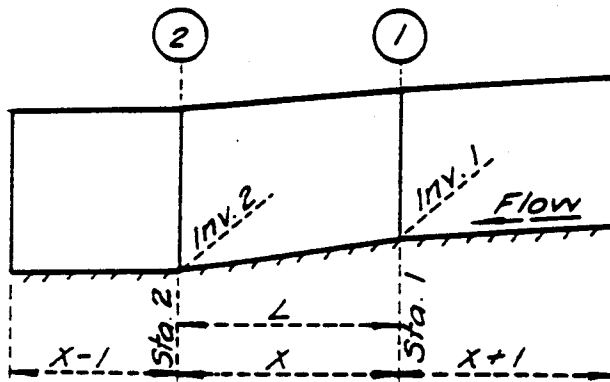

**ELEVATION**

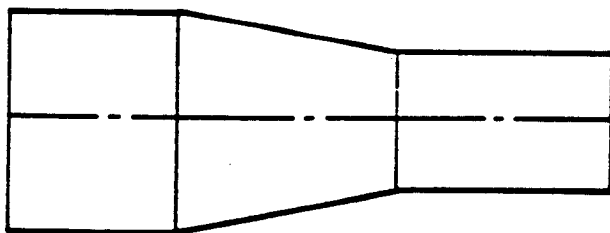

**PLAN**

**TRANSITION**

FIG. 5-6

# BRIDGE ENTRANCE

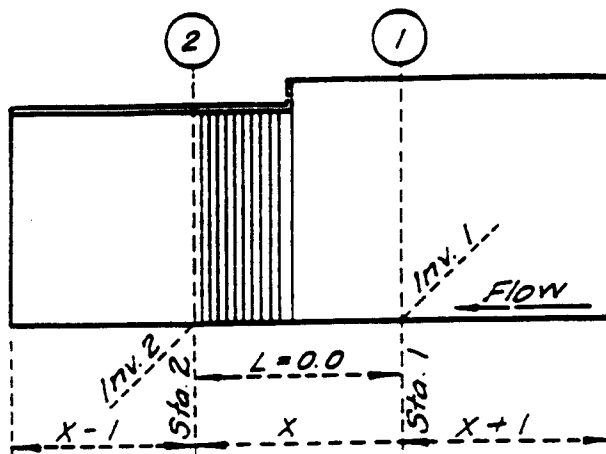

ELEVATION

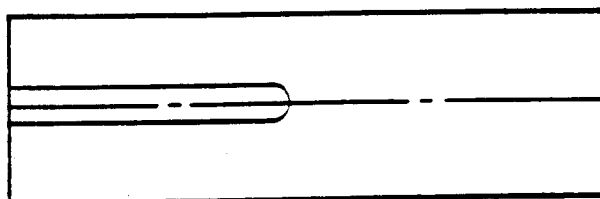

PLAN

FIG. 5-7

# BRIDGE EXIT

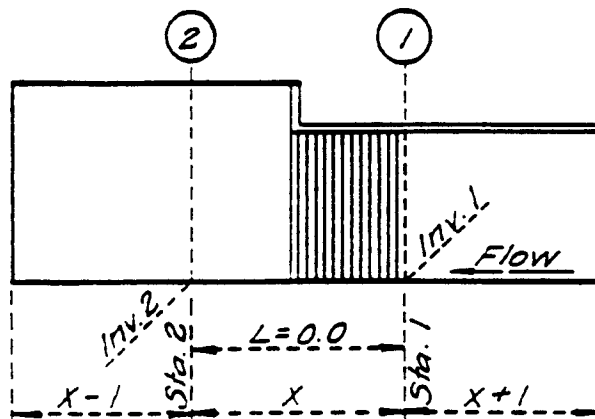

ELEVATION

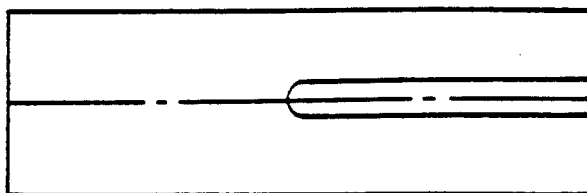

PLAN

FIG. 5-8

# WALL ENTRANCE / SUDDEN CONTRACTION

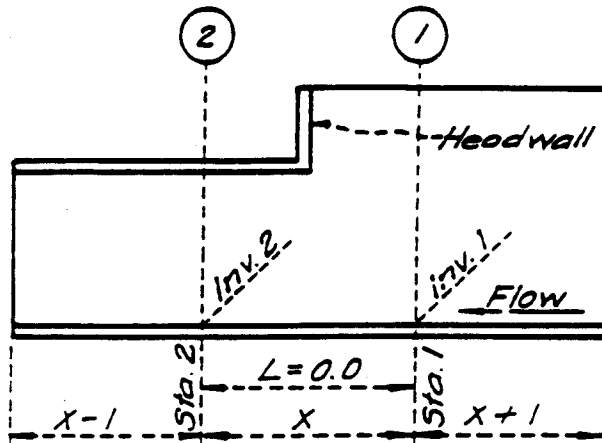

ELEVATION

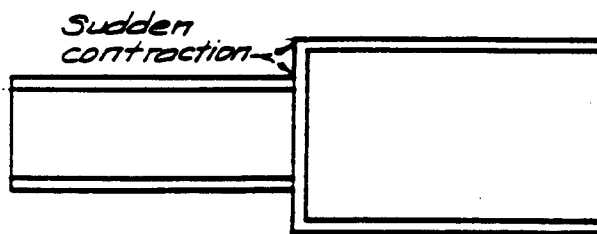

PLAN

FIG. 5-9

# WALL EXIT / SUDDEN EXPANSION

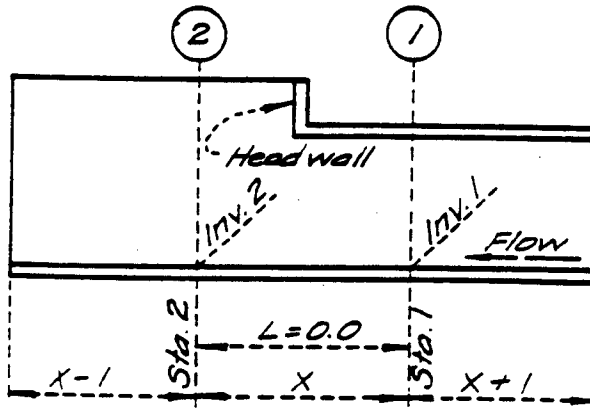

ELEVATION

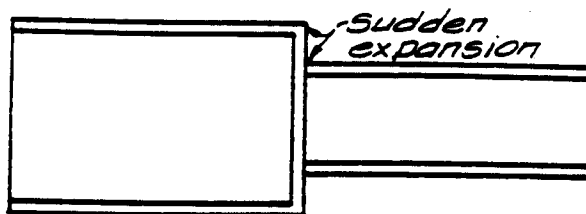

PLAN

FIG. 5-10

## 6.1 Channel and Conduit Section Description

Channels and conduits sections are classified as regular or irregular sections. The regular sections (Channel Types #1 - #4) are trapezoidal, rectangular channels, box conduits or pipes. The irregular sections (channel Types #5 and #6) can be natural river sections or irregular shaped improved sections with or without a cover. Piers or center walls can be included in any section except a pipe section.

### 6.1.1 Regular Channel Type Sections

The program utilizes the following regular sections:

Chan. Type # 1: Trapezoidal open top with or without piers. See Figure 6-1.

Chan. Type # 2: Rectangular open top with or without piers. See Figure 6-2.

Chan. Type # 3: Box, covered trapezoidal or covered rectangular with or without piers. See Figure 6-3.

Chan. Type # 4: Circular "pipe" one cell only. See Figure 6-4.

Note in multiple cell sections the cells may have variable width but must be of equal height and on the same invert elevation. The top elevation of all piers in both regular or irregular channels are assumed equal.

### 6.1.2 Irregular Sections

The program utilizes the following irregular cross sections:

Chan. Type # 5: Irregular open top with or without piers. See Figure 6-5.

Chan. Type # 6: Irregular covered top with or without piers. See figure 6-6.

### 6.1.3 Definitions & Restrictions for Irregular Sections

An irregular cross section (facing upstream) is defined by x and y coordinates of points i (x, y) given in a counter clockwise direction, from point i=1 to point i=n (minimum 3 points and maximum 99 points).

Point i = 1 (x, y) is where

x (1) = x min and if x (2) is also x minimum then  
y (1) is greater than y (2)

#### LIMITATIONS

Location of x and y axis:

The center of the reference axis (x=0,y=0) must not fall on the perimeter of the cross section.

Flow Line:

A section can have only one low flow channel.

Section Shape:

A section is allowed one minimum and maximum in the x and y directions. For example between points from x minimum to x maximum the consecutive values of x must be equal or greater. From x maximum to x minimum the consecutive values of x must be equal or smaller. The same holds in the y direction.

Piers:

The reference (x, y) axis for piers must be the same as used for the cross section. The "y" values are given from left to right.

# REGULAR CHANNELS

FIG. 6-1

Trapezoidal section with or without piers.

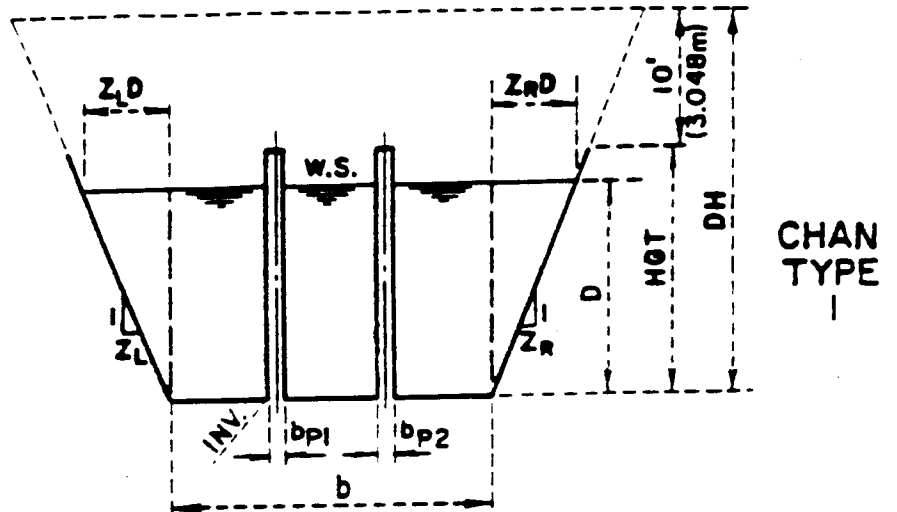

CHAN  
TYPE  
1

FIG. 6-2

Rectangular section with or without piers.

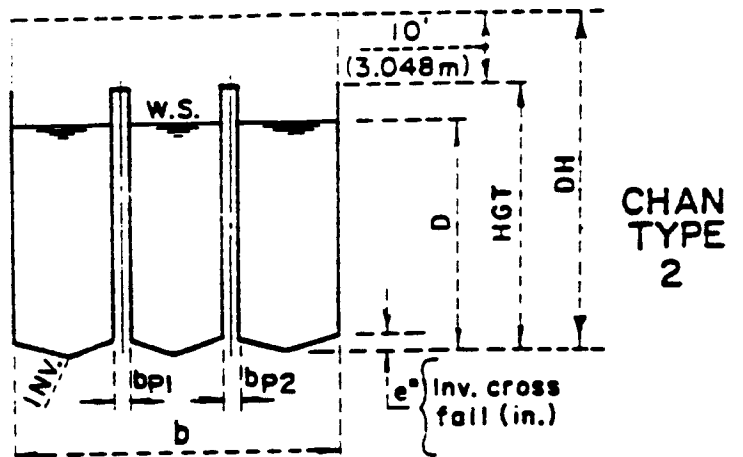

CHAN  
TYPE  
2

FIG. 6-3

Box culvert, covered trap or rectangular section with or without piers.

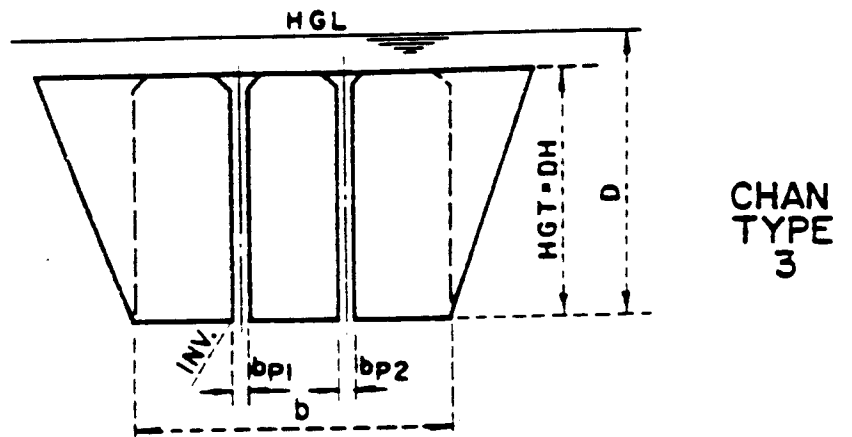

CHAN  
TYPE  
3

FIG. 6-4

Circular section (pipe) one cell only.

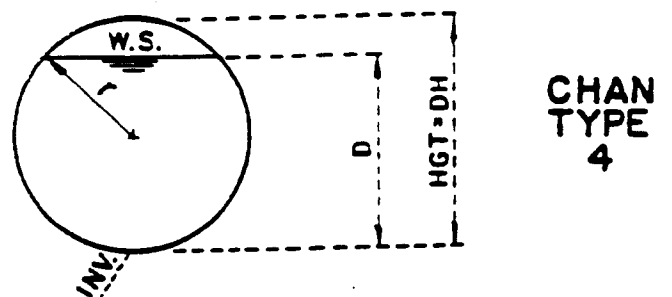

CHAN  
TYPE  
4

# IRREGULAR CHANNELS

**FIG. 6-5**

Irregular open top section with or without piers.

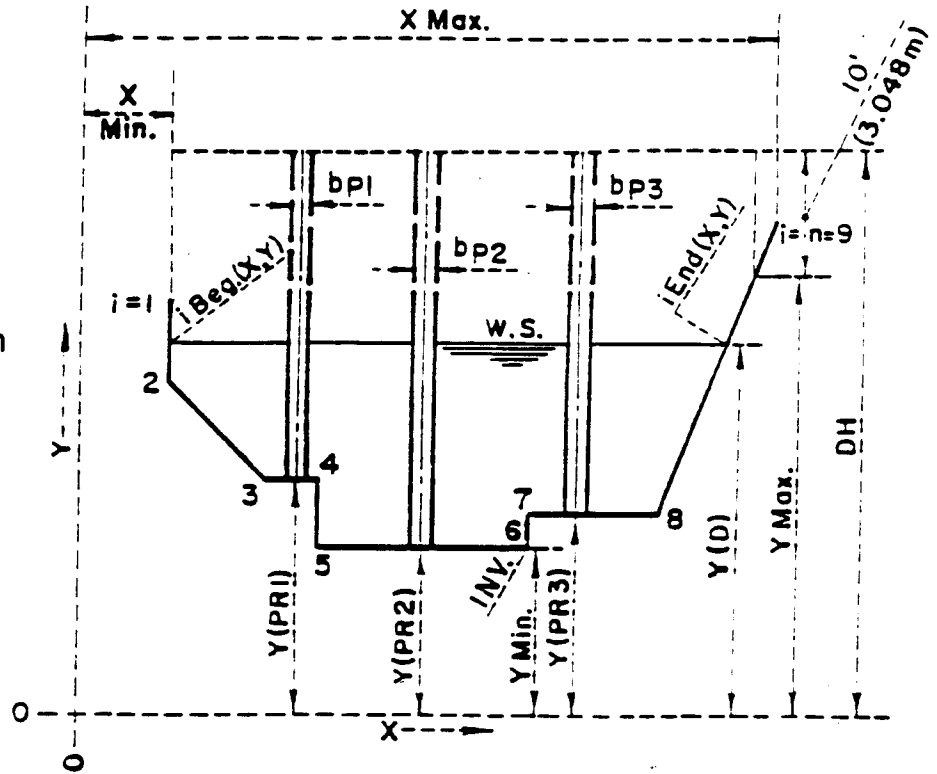

CHAN  
TYPE  
5

**FIG. 6-6**

Irregular covered section with or without piers.

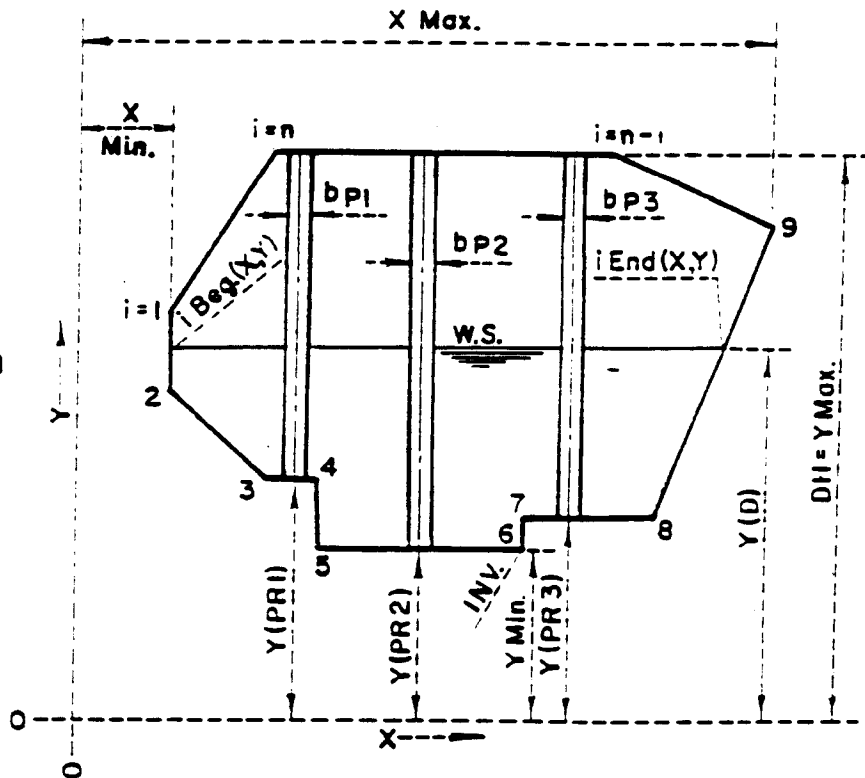

CHAN  
TYPE  
6



## 7.1 Input Data Description

This section contains the detailed description of each variable on each input card. With the exception of the three title cards all fields are fixed as indicated on the exhibits. If data is entered into a field the decimal points must be punched in the card column as shown.

Input data is placed by the user on Input Forms 1-4. All dimensions are in feet unless otherwise specified on the forms. Form 1 lists the title information and starting with the system outlet (SO) all elements are listed in chronological order upstream to the system headworks (SH). Form 2 is used to identify and list all data for regular cross sections, also to input data on piers for irregular cross sections. Form 3 is used to identify and list all irregular cross section data. Form 4 is used to list the starting Q at the system headworks. Form 4 is also used to list new starting Q's and optional Q factors when multiple water surface profile computation is desired.

7.1.1 TITLE CARDS

**LOS ANGELES COUNTY FLOOD CONTROL DISTRICT**  
**HYDRAULIC ANALYSIS COMPUTER PROGRAM**  
**FO515 (FORM NO. 1)**

Page \_\_\_\_\_ Of \_\_\_\_\_ Date \_\_\_\_\_  
 Name \_\_\_\_\_  
 Project \_\_\_\_\_

	1	2	3	4	5	6	7	8	9	0	1	2	3	4	5	6	7	8	9	0	1	2	3	4	5	6	7	8	9	0	1	2	3	4	5	6	7	8	9	0	1	2	3	4	5	6	7	8	9	0	1	2	3	4	5	6	7	8	9	0	1	2	3	4	5	6	7	8	9	0
T1	XX	XX	XX	XX	XX	XX	XX	XX	XX																																																													
T2	YY	YY	YY	YY	YY	YY	YY	YY	YY																																																													
T3	YY	YY	YY	YY	YY	YY	YY	YY	YY																																																													

Title Cards T1, T2, and T3

Title cards are entered once per project  
 Title cards are used for output title

First title card T1 is required to start processing

<u>Card Col.</u>	<u>Variable</u>	<u>Description</u>
1 & 2	T1	Card identification characters
4 - 80	None	Number and alphabetical characters for output title

20

Second title card T2 is an optional card

<u>Card Col.</u>	<u>Variable</u>	<u>Description</u>
1 & 2	T2	Card identification characters
4 - 80	None	Number and alphabetical characters for output title

Third title card T3 is an optional card

<u>Card Col.</u>	<u>Variable</u>	<u>Description</u>
1 & 2	T3	Card identification characters
4 - 80	None	Number and alphabetical characters for output title

**Legend**

XX Required  
 YY Optional

1

7.1.2 ELEMENT CARDS























### 7.1.3 CD CARD CHANNEL DEFINITION







7.1.4 PTS CARD "X & Y COORDINATES"

# LOS ANGELES COUNTY FLOOD CONTROL DISTRICT

## HYDRAULIC ANALYSIS COMPUTER PROGRAM

F0515 (FORM NO. 3)

Page \_\_\_\_\_ Of \_\_\_\_\_ Date \_\_\_\_\_

Name \_\_\_\_\_

Project \_\_\_\_\_

CARD CODE	CROSS SECT. IDENT. NO.							Pt. 1(x,y)									Pt. 1(x,y)									Pt. 1(x,y)									Pt. 1(x,y)									Pt. 1(x,y)																												
	1	2	3	4	5	6	7	X(i)			Y(i)			X(i)			Y(i)			X(i)			Y(i)			X(i)			Y(i)			X(i)			Y(i)			X(i)			Y(i)																															
1	P	T	S					.	.	.	.	.	.	.	.	.	.	.	.	.	.	.	.	.	.	.	.	.	.	.	.	.	.	.	.	.	.	.	.	.	.	.	.	.	.	.	.																									
2	P	T	S	X	X	X	X	X	X	.	.	.	X	X	X	.	.	.	X	X	X	.	.	.	X	X	X	.	.	.	Y	Y	.	.	.	.	Y	Y	.	.	.	.	Y	Y	.	.	.	.	Y	Y	.	.	.	.																		
3	P	T	S					.	.	.	.	.	.	.	.	.	.	.	.	.	.	.	.	.	.	.	.	.	.	.	.	.	.	.	.	.	.	.	.	.	.	.	.	.	.	.	.	.	.	.	.	.	.																			

Irregular Channel Cross Section Points (X,Y) Card "PTS".

The PTS card is used in conjunction with the CD card to define irregular channel cross sections (Chan. Type No. 5 or No. 6).

Card Col.	Variable	Description
1 & 3	PTS	Required card identification characters.
4 - 6	Cross Sect. Ident. No.	The number assigned on the CD card.*
7 - 8	No. of Points	Specifies the number of points i (X,Y) in a cross section.*
9 - 68	Pt i(X,Y) x(i), Y(i)	The X and Y coordinates of the points in a cross section entered in consecutive order from left to right. (minimum 3 pts and maximum of 99 pts).

Legend   XXX,XX   Required Data  
          YYY,YY   Optional Data

\* If more than one line (card) is required to define a cross section the Ident. No. and the No. of pts. are entered on the first line (card).

36

PTS

7.1.5 Q CARDS

# LOS ANGELES COUNTY FLOOD CONTROL DISTRICT

## HYDRAULIC ANALYSIS COMPUTER PROGRAM F0515 (FORM NO. 4)

Page \_\_\_\_\_ Of \_\_\_\_\_ Date \_\_\_\_\_  
 Name \_\_\_\_\_  
 Project \_\_\_\_\_

Q Card	Q at System Headworks									Q Factor																																													
	1	2	3	4	5	6	7	8	9	1	2	3	4	5	6	7	8	9	1	2	3	4	5	6	7	8	9	1	2	3	4	5	6	7	8	9	1	2	3	4	5	6	7	8	9										
1	Q									X	X	X	X	X	.					Y	.	Y																																	
2	Q									Y	Y	Y	Y	Y	.					Y	.	Y																																	
3	Q									Y	Y	Y	Y	Y	.					Y	.	Y																																	

### Q CARDS

The first Q card is a required card to specify the Q at the headworks.

Card Col.	Variable	Description
1	Q	Required card identification character.
11 - 18	Q at S.H.	Q in cfs at the headworks.

38

### Second, Third --- nth Q card

These are optional cards used to obtain w.s./hgl profiles for different flow rates in the system (see Sec. 3.3.3 for program limitation)

Card Col.	Variable	Description
1	Q	Required card identification character.
11 - 18	Q at S.H.	New Q at the system headworks.
21 - 25	Q factor	A multiplier which alters all lateral inflow in the system.

Legend XXX,XX Required Data  
 YYY,YY Optional Data



7.1.6 CONTROL CASES

## Control Cards

The District user need generally not be concerned with the control cards. However, if additional data on specific runs is required the following options are provided.

Control Card No. 1 - (trace switch card)

This is a required card that is placed ahead of the title cards. A "0" placed in CC 1 results in the regular composite water surface profile printout. (the District's Data processing center always includes this card with a 0 in CC1 unless otherwise instructed.) If "1" is placed in CC1 the element file will be included in the print out.

Control Card No. 2 - (JDEBUG)

This is a required card that is placed immediately before the Q CARDS. A 0 (zero) is placed in CC1 results in the regular composite water surface profile printout and plot. (The District's Data processing center always includes this card with a 0 (zero) in CC1 unless otherwise instructed) A "1" placed in CC1 results in the regular composite watersurface profile print out and plot and in addition prints out the lower and upper stage profiles and prints computational flow. A "2" placed in CC1 results in the regular composite water surface profile print out and plot and in addition prints out the lower and upper stage flow profiles.

## 7.2 SAMPLE INPUT



Los Angeles County  
Flood Control District

DATA CENTER JOB WORK ORDER

DATE 2/27/79

DATE WANTED SAME

DIVISION DESIGN

PROGRAM No. F0515P

Job Requested	Punch	<input checked="" type="checkbox"/>
	Verify	<input checked="" type="checkbox"/>
	Reproduce	<input type="checkbox"/>
	Corrections	<input type="checkbox"/>
	Interpret	<input type="checkbox"/>
	Sort	<input type="checkbox"/>
	Merge	<input type="checkbox"/>
	Computer On-line	<input checked="" type="checkbox"/>
	Off-line Listing	<input type="checkbox"/>

SPECIAL INSTRUCTIONS:

LAST CARD IS A  
Q CARD

Requested By	NAME GARVIN P. ROBERTSON
	PHONE 4088
	ROOM 123-E

1788 FCD 1/78





# LOS ANGELES COUNTY FLOOD CONTROL DISTRICT

## HYDRAULIC ANALYSIS COMPUTER PROGRAM FOSIS (FORM NO. 4)

Page 3 of 3 Date 2/27/79  
 Name GARYN J. PEPPERSON  
 Project No. 9202

	Q of System Headworks										Q Factor																																							
	1	2	3	4	5	6	7	8	9	0	1	2	3	4	5	6	7	8	9	0	1	2	3	4	5	6	7	8	9	0	1	2	3	4	5	6	7	8	9	0										
1	Q										5	7	5	.							1																													
2	Q																				.																													
3	Q																				.																													
4	Q																				.																													
5	Q																				.																													
6	Q																				.																													
7	Q																				.																													
8	Q																				.																													
9	Q																				.																													
10	Q																				.																													
11	Q																				.																													
12	Q																				.																													
13	Q																				.																													
14	Q																				.																													
15	Q																				.																													
16	Q																				.																													
17																																																		
18																																																		
19																																																		
20																																																		
21																																																		
22																																																		
23																																																		
24																																																		
25																																																		
26																																																		

57

Los Angeles County  
Flood Control District

DATA CENTER JOB WORK ORDER

DATE		2/28/79	
DATE WANTED		Same	
DIVISION		DESIGN	
PROGRAM No.		F 0515P	
Job Requested	Punch		<input checked="" type="checkbox"/>
	Verify		<input checked="" type="checkbox"/>
	Reproduce		<input type="checkbox"/>
	Corrections		<input type="checkbox"/>
	Interpret		<input type="checkbox"/>
	Sort		<input type="checkbox"/>
	Merge		<input type="checkbox"/>
	Computer On-line		<input checked="" type="checkbox"/>
	Off-line Listing		<input type="checkbox"/>
SPECIAL INSTRUCTIONS:			
<p>LAST CARD IS A Q CARD</p>			
Requested By	NAME	SAMAN J. SHAHIN	
	PHONE	4085	
	ROOM	123-E	

123-500-1000

LOS ANGELES COUNTY FLOOD CONTROL DISTRICT  
 HYDRAULIC ANALYSIS COMPUTER PROGRAM  
 F0515 (FORM NO. 1)

Page 1 of 3 Date 2/28/79  
 Name Saman J. Shahin  
 Project Ballona Creek

ELEM TYPE		STA 1									INV 1									CROSS SECT IDENT NO FROM FORM NO. 203									MANUSCRIPT n									NO ELEV. AT 80 AND OR 84									RADIUS OF CURVE									POINT																																																																																			
																				ASYM LATERAL									Q <sub>3</sub>									Q <sub>4</sub>									INV 3									INV 4									φ <sub>3</sub> φ° CONF									φ <sub>4</sub> φ° CONF																																																																	
																				ELEM ONE TWO																																																																																																																							
1	2	3	4	5	6	7	8	9	0	1	2	3	4	5	6	7	8	9	0	1	2	3	4	5	6	7	8	9	0	1	2	3	4	5	6	7	8	9	0	1	2	3	4	5	6	7	8	9	0	1	2	3	4	5	6	7	8	9	0	1	2	3	4	5	6	7	8	9	0	1	2	3	4	5	6	7	8	9	0	1	2	3	4	5	6	7	8	9	0	1	2	3	4	5	6	7	8	9	0	1	2	3	4	5	6	7	8	9	0	1	2	3	4	5	6	7	8	9	0																				
1	SO	20600	0	0	0	0	0	0	0	7	1	5	4							1																																																																																																																							
2	R	20800	0	0	0	0	0	0	0	9	9	4								1																																																																																																																							
3	R	21300	0	0	0	0	0	0	0	10	9	5								1																																																																																																																							
4	BX																			2																																																																																																																							
5	R	21360	0	0	0	0	0	0	0	11	1	1								2																																																																																																																							
6	BE																			1																																																																																																																							
7	R	22319	76							13	0	0								1																																																																																																																							
8	R	22119	76							15	0	0								1																																																																																																																							
9	R	22430	68							15	1	1								1																																																																																																																							
10	BX																			3																																																																																																																							
11	R	22560	68							15	3	7								3																																																																																																																							
12	BE																			1																																																																																																																							
13	R	25500	00							23	0	8								1																																																																																																																							
14	SI																			1																																																																																																																							

47







## 8.1 OUTPUT DATA DESCRIPTION

### 8.1.1 Normal Output

- a) Listing of channel cross section definitions (CD card data)
- b) Listing irregular channel cross section points (PTS data)
- c) Listing of element input data
- d) Listing of title data
- e) Listing of computed water surface profile or pressure gradient data
- f) Plotting of the conduit and water surface data
- g) If additional Q's cards are inputted then multiple output will occur for each set of Q's

### 8.1.2 Optional Output

Program F0515P will provide, in addition to the above output, a listing of all lower stage water surface profile points and all upper stage water surface profile points.

```

FFFFFFFF 00000000 5555555555 11 5555555555 PPPPPPPPPP
FFFFFFFF 00000000 5555555555 111 5555555555 PPPPPPPPPP
FF 00 0000 55 1111 55 PP PP
FF 00 00 00 55 11 55 PP PP
FF 00 00 00 55 11 55 PP PP
FFFFFFFF 00 00 00 55555555 11 55555555 PPPPPPPPPP
FFFFFFFF 00 00 00 55555555 11 55555555 PPPPPPPPPP
FF 00 00 00 55 11 55 PP
FF 0000 00 55 11 55 PP
FF 000 00 55 11 55 PP
FF 00000000 5555555555 111111111 5555555555 PP
FF 00000000 5555555555 111111111 5555555555 PP

```

```

JJJJJJJJ 999999999 444 11
JJJJJJJJ 99999999999 4444 111
JJ 99 44 44 1111
JJ 99 99 44 44 11
JJ 99 99 44 44 11
JJ 99999999999 44444444444 11
JJ 99999999999 4444444444444 11
JJ 99 44 11
JJ JJ 99 44 11
JJ JJ 99 44 11
JJJJJJJJ 99999999999 44 111111111
JJJJJJ 9999999999 44 111111111

```

52

```

****A FND JOB 941 F0515P B1N42 ROOM A10R 2.09.13 PM 0R MAR 79 R4.PRI SYS 155R JOB 941 FND A****
****A FND JOB 941 F0515P B1N42 ROOM A10R 2.09.13 PM 0R MAR 79 R4.PRI SYS 155R JOB 941 FND A****
****A FND JOB 941 F0515P B1N42 ROOM A10R 2.09.13 PM 0R MAR 79 R4.PRI SYS 155R JOB 941 FND A****
****A FND JOB 941 F0515P B1N42 ROOM A10R 2.09.13 PM 0R MAR 79 R4.PRI SYS 155R JOB 941 FND A****
****A FND JOB 941 F0515P B1N42 ROOM A10R 2.09.13 PM 0R MAR 79 R4.PRI SYS 155R JOB 941 FND A****

```

## FOSTSP

## WATER SURFACE PROFILE - CHANNEL DEFINITION LISTING

PAGE 1

CARD CODE	SECT NO	CHN TYPE	NO OF PIERS	AVE PIER WIDTH	HEIGHT 1 DIAMETER	BASE WIDTH	ZL	ZR	INV DROP	Y(1)	Y(2)	Y(3)	Y(4)	Y(5)	Y(6)	Y(7)	Y(8)	Y(9)	Y(10)
CD	1	3	0	0.0	8.50	7.08	0.0	0.0	0.0										
CD	2	4			5.00														
CD	3	4			7.50														
CD	4	4			3.75														

F O S I S P

PAGE NO 1

WATER SURFACE PROFILE - TITLE CARD LISTING

WATER SURFACE PROFILE - TITLE CARD LISTING

HEADING LINE NO 1 IS -

PROJ NO 9202 UNIT 1, STA 372+20 TO 75+00

HEADING LINE NO 2 IS -

SAMPLE PROBLEM ENTERED BY GARVIN J. PEDERSON DATE : FEB 27 , 1979

HEADING LINE NO 3 IS -

TYPICAL BOX AND PIPE STORM DRAIN.

WATER SURFACE PROFILE - TITLE CARD LISTING

WATER SURFACE PROFILE - ELEMENT CARD LISTING

ELEMENT NO	DESCRIPTION	STATION	INVERT	SECT	N	03	04	INVERT-3	INVERT-4	PHI 3	PHI 4	RADIUS	ANGLE	ANG PT	MAN H
1	IS A SYSTEM OUTLET	3720.00	740.48	1											
2	IS A REACH	4000.50	741.40	1	0.013							0.0	16.00	0.0	0
3	IS A JUNCTION	4016.50	741.46	1	0.013	140.0	0.0	741.60	0.0	30.00	0.0				
4	IS A REACH	4030.00	741.50	1	0.013							0.0	0.0	0.0	1
5	IS A REACH	4170.00	747.05	1	0.013							0.0	0.0	0.0	0
6	IS A REACH	5240.00	751.70	1	0.013							0.0	0.0	0.0	0
7	IS A REACH	6628.90	752.51	1	0.013							0.0	0.0	0.0	3
8	IS A JUNCTION	6640.90	752.53	3	0.013	85.0	0.0	752.80	0.0	30.00	0.0				
9	IS A REACH	6800.00	758.70	3	0.013							0.0	0.0	0.0	0
10	IS A REACH	7490.00	762.52	3	0.013							0.0	0.0	6.50	0
11	IS A REACH	7500.00	762.53	3	0.013							0.0	0.0	0.0	0
12	IS A SYSTEM HEADWORKS	7500.00	762.53	3											

W S ELEV  
752.20

W S ELEV  
0.0

F O S I S P

PAGE NO 3

WATER SURFACE PROFILE - TITLE CARD LISTING

WATER SURFACE PROFILE - ELEMENT CARD LISTING

NO EDIT ERRORS ENCOUNTERED-COMPUTATION IS NOW BEGINNING

\*\* WARNING NO. 2 \*\* - WATER SURFACE ELEVATION GIVEN IS LESS THAN OR EQUALS INVERT ELEVATION IN ROWS. W.S.ELEV = INV + DC

F0515P  
 WATER SURFACE PROFILE LISTING  
 PROJ NO 9202 LINE 1, STA 372+20 TO 75+00  
 SAMPLE PROFILE ENTERED BY GARVIN J. PEDERSON    DATE : FEB 27 , 1979  
 TYPICAL BOX AND PIPE STORM DRAIN.

STATION	INVERT ELEV	DEPTH OF FLOW	W.S. ELEV	O	VFI	VFI HEAD	ENERGY GRD.EI.	SUPR ELEV	CRITICAL DEPTH	HGT/ DIA	BASE/ ID NO.	ZI	NO PIER	AVRPR
I/ELEV	SO					SF	AVF	HF		NORM DEPTH		ZR		
3720.00	740.48	11.720	752.200	800.0	13.35	2.767	754.967	0.0	7.349	8.50	7.08	0.0	0	0.0
280.50	0.00328					.005702	1.60			8.500		0.0		
4000.50	741.40	12.633	754.033	800.0	13.35	2.767	756.800	0.0	7.349	8.50	7.08	0.0	0	0.0
JUNCT STR	0.00375					.006791	0.08					0.0		
4016.50	741.46	13.969	755.429	660.0	11.01	1.883	757.312	0.0	6.464	8.50	7.08	0.0	0	0.0
13.50	0.00296					.003881	0.05			8.195		0.0		
4030.00	741.50	14.075	755.575	660.0	11.01	1.883	757.458	0.0	6.464	8.50	7.08	0.0	0	0.0
58 140.00	0.03966					.003881	0.54			2.974		0.0		
4170.00	747.05	9.069	756.119	660.0	11.01	1.883	758.002	0.0	6.464	8.50	7.08	0.0	0	0.0
1070.00	0.00435					.003881	4.15			6.997		0.0		
5240.00	751.70	8.854	760.554	660.0	11.01	1.883	762.437	0.0	6.464	8.50	7.08	0.0	0	0.0
1388.90	0.00058					.003881	5.39			8.500		0.0		
6628.90	752.51	13.716	766.226	660.0	11.01	1.883	768.109	0.0	6.464	8.50	7.08	0.0	0	0.0
JUNCT STR	0.00100					.004764	0.09					0.0		
6648.90	752.53	13.324	765.856	575.0	13.02	2.630	768.484	0.0	6.172	7.50	0.0	0.0	0	0.0
151.10	0.04083					.005607	0.85			3.161		0.0		
6800.00	758.70	8.002	766.702	575.0	13.02	2.630	769.332	0.0	6.172	7.50	0.0	0.0	0	0.0
690.00	0.00554					.005607	3.87			6.192		0.0		
7490.00	762.52	8.090	770.610	575.0	13.02	2.630	773.240	0.0	6.172	7.50	0.0	0.0	0	0.0
10.00	0.00100					.005607	0.06			7.500		0.0		
7500.00	762.53	8.136	770.666	575.0	13.02	2.630	773.296	0.0	6.172	7.50	0.0	0.0	0	0.0





NOTES

1. GLOSSARY

- I = INVERT ELEVATION
- C = CRITICAL DEPTH
- W = WATER SURFACE ELEVATION
- H = HEIGHT OF CHANNEL
- E = ENERGY GRADE LINE
- X = CURVES CROSSING OVER
- B = BRIDGE ENTRANCE OR EXIT
- Y = WALL ENTRANCE OR EXIT

2. STATIONS FOR POINTS AT A JUMP MAY NOT BE PLOTTED EXACTLY



F0515P

WATER SURFACE PROFILE - CHANNEL DEFINITION LISTING

CARD CODE	SECT NO	CHN TYPE	NO OF PIERS	AVE PIER WIDTH	HEIGHT   DIAMETER	BASE WIDTH	ZL	ZR	INV DROP	Y(1)	Y(2)	Y(3)	Y(4)	Y(5)	Y(6)	Y(7)	Y(8)	Y(9)	Y(10)
CD	1	1	0	0.0	30.00	80.00	3.00	3.00	0.0										
CD	2	3	1	2.50	30.00	80.00	3.00	3.00	0.0										
CD	3	3	2	1.25	30.00	80.00	3.00	3.00	0.0										

F 0 5 1 5 P

PAGE NO 1

WATER SURFACE PROFILE - TITLE CARD LISTING

WATER SURFACE PROFILE - TITLE CARD LISTING

HEADING LINE NO 1 IS -

HALLINA CREEK , STA 206+00 TO 255+00

HEADING LINE NO 2 IS -

SAMPLE PROBLEM ENTERED BY SAMAN J. SHAHIN      DATE : FEB 27 , 1979

HEADING LINE NO 3 IS -

TYPICAL TRAPEZOIDAL CHANNEL WITH PIERS .

03

WATER SURFACE PROFILE - TITLE CARD LISTING

WATER SURFACE PROFILE - ELEMENT CARD LISTING

ELEMENT NO	DESCRIPTION	U/S DATA	STATION	INVERT	SECT	W S ELEV	RADIUS	ANGLE	ANG PT	MAN H
1	IS A SYSTEM INLET		20600.00	9.54	1	0.0				
2	IS A REACH		21300.00	10.95	1	N 0.014	0.0	0.0	0.0	0
3	IS A BRIDGE EXIT		21300.00	10.95	2					
4	IS A REACH		21380.00	11.11	2	N 0.014	0.0	0.0	0.0	0
5	IS A BRIDGE ENTRANCE		21380.00	11.11	1	EP 0.670				
6	IS A REACH		22319.76	13.00	1	N 0.014	0.0	0.0	0.0	0
7	IS A REACH		22419.76	15.00	1	N 0.014	0.0	0.0	0.0	0
8	IS A REACH		22460.68	15.11	1	N 0.014	0.0	0.0	0.0	0
9	IS A BRIDGE EXIT		22460.68	15.11	3					
10	IS A REACH		22560.68	15.37	3	N 0.014	0.0	0.0	0.0	0
11	IS A BRIDGE ENTRANCE		22560.68	15.37	1	EP 0.670				
12	IS A REACH		25500.00	23.08	1	N 0.014	0.0	0.0	0.0	0
13	IS A SYSTEM HEADWORKS		25500.00	23.08	1					

NO EDIT ERRORS ENCOUNTERED-COMPUTATION IS NOW BEGINNING

W S ELEV  
0.0

\*\* WARNING NO. 2 \*\* - WATER SURFACE ELEVATION GIVEN IS LESS THAN OR EQUALS INVERT ELEVATION IN ROWS. W.S.ELEV = INV + 10.





FO515P  
 WATER SURFACE PROFILE LISTING  
 BALLONA CREEK , STA 206+00 TO 255+00  
 SAMPLE PROFILE ENTERED BY SAMAN J. SHAHIN    DATE : FEB 27 , 1979  
 TYPICAL TRAPEZOIDAL CHANNEL WITH PIERS .

STATION	INVERT ELEV	DEPTH OF FLOW	W. S. ELEV	0	VEL	VEL HEAD	ENERGY GRD. EL.	SUPER ELEV	CRITICAL DEPTH	HGT/ DIA	BASE/ TD NO.	ZI	NO PIER	AVRPR
L/FLEM	SO					SE AVE	HE			NORM DEPTH			ZR	
22460.68	15.11	17.552	32.662	58500.0	25.61	10.182	42.844	0.0	20.055	30.00	80.00	3.00	2	1.25
100.00	0.00260					.003222	0.32			18.531			3.00	
22560.68	15.37	17.456	32.826	58500.0	25.81	10.340	43.166	0.0	20.055	30.00	80.00	3.00	2	1.25
BRIDGE ENTRANCE													3.00	
22560.68	15.37	16.566	31.936	58500.0	27.23	11.512	43.448	0.0	19.830	30.00	80.00	3.00	0	0.0
880.52	0.00262					.002469	2.16			16.357			3.00	
23441.20	17.68	16.738	34.418	58500.0	26.84	11.187	45.605	0.0	19.830	30.00	80.00	3.00	0	0.0
1164.95	0.00262					.002251	2.62			16.357			3.00	
24606.15	20.73	17.322	38.057	58500.0	25.59	10.170	48.227	0.0	19.830	30.00	80.00	3.00	0	0.0
497.35	0.00262					.001972	0.98			16.357			3.00	
25103.50	22.04	17.922	39.962	58500.0	24.40	9.246	49.208	0.0	19.830	30.00	80.00	3.00	0	0.0
248.62	0.00262					.001728	0.43			16.357			3.00	
25352.12	22.69	18.560	41.232	58500.0	23.27	8.405	49.637	0.0	19.830	30.00	80.00	3.00	0	0.0
116.02	0.00262					.001514	0.18			16.357			3.00	
25468.14	23.00	19.176	42.172	58500.0	22.18	7.641	49.813	0.0	19.830	30.00	80.00	3.00	0	0.0
31.86	0.00262					.001326	0.04			16.357			3.00	
25500.00	23.08	19.830	42.910	58500.0	21.15	6.945	49.855	0.0	19.830	30.00	80.00	3.00	0	0.0

35

RAJLONA CREEK , STA 206+00 TO 254+00  
 SAMPLE PROGRAM ENTERED BY SAMAN J. SHAHIN DATE 1 FEB 27 , 1979  
 TYPICAL TRAPEZOIDAL CHANNEL WITH PIERS .

58

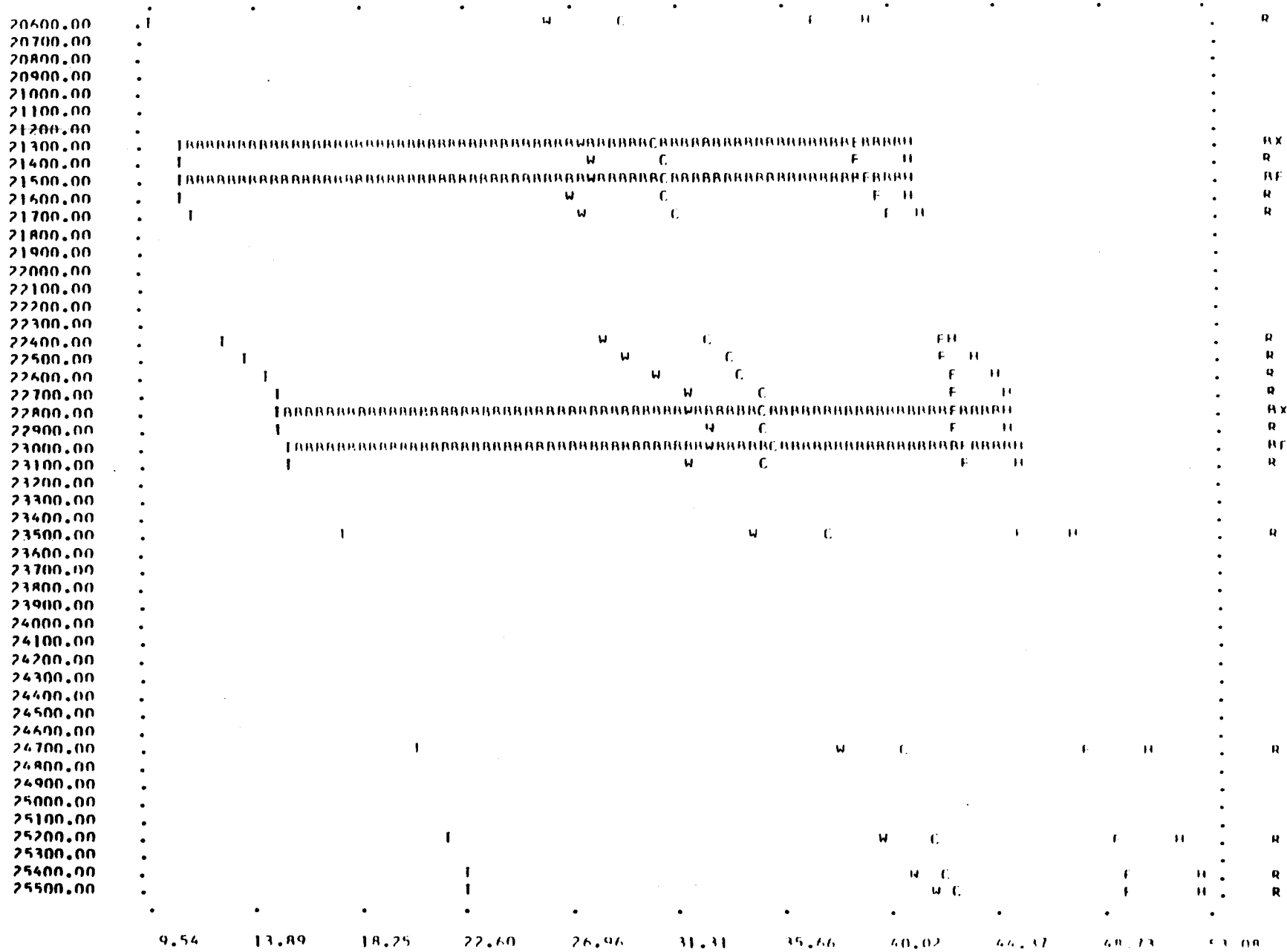

**N O T E S**

**1. GLOSSARY**

- I = INVERT ELEVATION**
- C = CRITICAL DEPTH**
- W = WATER SURFACE ELEVATION**
- H = HEIGHT OF CHANNEL**
- E = ENERGY GRADE LINE**
- X = CURVES CROSSING OVER**
- R = BRIDGE ENTRANCE OR EXIT**
- Y = WALL ENTRANCE OR EXIT**

**2. STATIONS FOR POINTS AT A JUMP MAY NOT BE PLOTTED EXACTLY**

## 9.1 ERROR MESSAGES AND EXPLANATIONS

### 9.1.1 ERROR MESSAGES IN EDITING THE ELEMENT CARDS

- 1) THE ABOVE SYSTEM OUTLET WAS FOUND TO BE IN ERROR -  
ELEMENT NOT EQUAL TO 001  
  
The system outlet must be the first element to be processed.  
Check order of input to make sure the system outlet card follows  
the title cards.
- 2) THE ABOVE INPUT CARD DID NOT CONTAIN THE REQUIRED DATA  
XXX  
  
Check the data on the input card with the input documentation for  
that element to make sure all the required data is present, see a  
programmer if data is correct.
- 3) THE ABOVE INPUT CARD CONTAINED AN INVALID ELEMENT NUMBER  
  
The above card contained an invalid code in the element type field.  
Check input field with input documentation description and correct  
data.
- 4) THE ABOVE INPUT CARD CONTAINED AN INVALID STATION  
  
The station on the above card was not in sequence with the  
previous stations. The value was less than the station of the  
previous element. Correct input data.
- 5) THE ABOVE INPUT CARD CONTAINED AN INVALID INVERT
- 6) DURING EDIT PHASE XXX ERRORS WERE ENCOUNTERED -  
PROCESSING WILL NOT START  
  
The number of errors in the edit phase is printed. The calculations  
will not begin until all edit errors have been corrected.
- 7) NO EDIT ERRORS ENCOUNTERED - COMPUTATION IS NOW  
BEGINNING  
  
This message indicates that all of the input data was correct and  
processing calculations will begin.
- 8) A BLANK INVERT WAS GIVEN ON AN ELEMENT CARD  
  
The above card was required to have an invert but none was given,  
check and correct input data.

9) INVALID SECTION NUMBER ON ELEMENT CARD

The section number given for this element is not between 1 and 200. Correct input with correct channel number reference.

10) SECTION NUMBER HAD NO DATA FOR CHANNEL DEFINITION

The section number on the element card refers to a section that was not defined or that was labeled as being in error in editing the channel definition cards. Check the channel number and the results from the channel definition editing.

11) SECTION NUMBER HAD NO DATA FOR CROSS SECTION

Same as Message No. 10 only for cross section data instead of channel definition data.

12) THE CHANNEL DEFINITION REFERENCED DID NOT CONTAIN THE REQUIRED DATA TO BE USED IN THIS ELEMENT

There is a conflict between the data in the channel definition used to describe this element and the type of element being described. Check the restrictions for this element and make sure the channel definition selected has applicable data.

13) THE PREVIOUS SECTION OR CHANNEL DEFINITION DID NOT COINCIDE WITH THE DATA UTILIZED IN THIS ELEMENT

There is a conflict between the data in the channel definitions of the previous element and the current element being used in the element being described. Check the restrictions for the element type and the channel definition data used.

### 9.1.2 WARNING MESSAGES IN EDITING THE ELEMENT CARDS

- 1) THE ABOVE ELEMENT CONTAINED AN INVERT ELEV WHICH WAS NOT GREATER THAN THE PREVIOUS INVERT ELEV.

Check the inverts on the preceeding and current elements to make sure they are what you want. Program assumes data is good and continues.

- 2) WARNING - ADJACENT SECTIONS ARE NOT IDENTICAL - SEE SECTION NUMBERS AND CHANNEL DEFINITIONS

The two adjacent sections are supposed to be identical, but if only the channel height varies it is alright. Check channel definitions to see if data is correct and only height varies, program assumes data is correct and continues.

- 3) WARNING - PREVIOUS SECTION NUMBER WAS INVALID OR 0 - SEE PREVIOUS DESCRIPTION

Previous element should have been flagged as being bad so the data passed to this element is zeroes. Processing for the other elements continues.

9.1.3 ERROR MESSAGES IN SEQUENCE CHECKING THRU CHANNEL DEFINITION DATA

- 1) NO SYSTEM HEADWORKS CARD - CANNOT TELL WHERE THE START OF CHANNEL DEFINITION DATA IS - NO PROCESSING

There must be a system headworks card at the end of the element cards just preceding the channel definition cards. Check input data.

- 2) CHANNEL DEFINITION DATA (CD) DID NOT FOLLOW THE SYSTEMS HEADWORKS CARD - CONTINUING TO LOOK FOR CD OR PTS

There must be at least one CD card following the system headworks card, and all CD cards follow the system headworks and come before the cross section points (PTS) cards. Check input data.

- 3) NO CHANNEL DEFINITION (CD) OR CROSS SECTION POINT CARDS (PTS) WERE RECOGNIZED - CHECK DATA

There must be at least one channel definition card following the system headworks card. Check input data card code columns.

- 4) NO CHANNEL DEFINITION CARDS BEFORE CROSS SECTION POINT CARDS - CHECK DATA

Check order of input cards. Element cards ending with system headworks must be followed by at least one channel definition card. Cross section point cards follow the channel definition cards.

- 5) INVALID CHANNEL TYPE ON CHANNEL DEFINITION CARD  
ITYPE = X SECT = XXX

ITYPE is the channel type requested and SECT is the section number the channel type is specified to define. Channel type must be a number between 1 and 6. Check and correct this CD card.

- 6) NO CROSS SECTION POINTS ENCOUNTERED - ASSUME NO IRREGULAR CHANNELS

No irregular channels or cross section points are indicated for this problem. This is a warning message. Processing will continue.

- 7) INVALID CARD CODE ENCOUNTERED WHILE PROCESSING CD AND PTS CARDS CODE = XXX

After the first CD card a card was found which did not have a code of CD or PTS. CODE indicates the invalid card code which should be corrected or placed in the correct order.



- 8) NO SYSTEM HEADWORKS CARD BEFORE CHANNEL DEFINITION  
OR CROSS SECTION POINTS

The system headworks card was omitted or is out of sequence. It should be the last element card and should immediately precede the channel definition cards.

#### 9.1.4 ERROR MESSAGES IN SEQUENCE CHECKING CROSS SECTION POINTS CARDS

- 1) INVALID OR MISSING NUMBER OF POINTS VALUE - MUST BE BETWEEN 3 AND 99. CODE = XXX ISECT = XXX NO PTS = XX

The number of points value is in error or the card is out of sequence, make sure this is supposed to be the first card of a cross section for the section points. CODE is the card code, ISECT is the section number and NO PTS is the number of points indicated. Correct the invalid card and resubmit.

- 2) INVALID CARD CODE FOR CROSS SECTION POINTS

While processing PTS cards a code not equal to PTS was found. Either wrong or out of sequence. Correct the data error.

- 3) STARTED ANOTHER CROSS SECTION GROUP BEFORE PREVIOUS GROUP WAS COMPLETED.

A new cross section group was indicated (no of points was given) before all the points indicated by the previous the number of points were read. Check card sequencing and make sure the number of points is only on the first card of a section and is correct with the number of points to be read.

- 4) SECTION NUMBER IS INVALID OR MISSING - MUST BE BETWEEN 1 AND 200 CODE = XXX ISECT = XXX NO PTS = XXX

The section number given is in error. CODE is the card code, ISECT is the invalid section no. and NO PTS is the number of points. Correct the invalid cross section points card and resubmit.

- 5) END OF FILE BEFORE ALL POINTS WERE READ ON LAST CROSS SECTION

The last input card was read before all the points indicated to exist in the current cross section were read. Supply the remaining cross section points cards to complete the section or correct the number of points indicated to define the section.

- 6) END OF FILE ON CROSS SECTION POINTS

The last cross section points card was read and processing in this program is completed.

- 7) NO CHANNEL DEFINITION RECORD FOR THIS SECTION CODE - GOING ON TO NEXT CROSS SECTION SECT = XXX

There was no channel definition or an invalid channel definition was given at the corresponding section number so no processing is done on these cross section points.

8) MISSING NUMBER OF POINTS FOR CODE XXX FOR SECTION XXX

The first card to describe the cross section points of a section did not have the number of points value to indicate how many points are to be read to describe the channel. Make sure this is supposed to be the first card of the section points and supply the number of points value for the section; if it is not supposed to be the first card of the section points put the cards in their proper sequence.

### 9.1.5 ERROR MESSAGES IN CHANNEL DEFINITION PROCESSING

- 1) SECTION NUMBER INVALID OR MISSING, DATA CANNOT BE WRITTEN TO THE OUTPUT FILE

There was an invalid section number on a CD or PTS card. Section number must be between 1 and 200. Correct invalid data.

- 2) INVALID VALUE FOR THE NUMBER OF PIERS - MUST BE BETWEEN 0 AND 10 IF GIVEN

The number of piers on the CD card is invalid. Correct the invalid data.

- 3) AVERAGE WIDTH OF PIERS IS INVALID OR NOT GIVEN WHEN THERE IS A VALUE FOR NUMBER OF PIERS IN THE CHANNEL

When number of piers is given there must be a value for average width of piers. Correct whichever field is wrong.

- 4) CHANNEL HEIGHT IS INVALID OR IS NOT GIVEN

Correct the height data in the channel definition.

- 5) CHANNEL DIAMETER IS INVALID OR IS NOT GIVEN

Correct the width data in the channel definition.

- 6) CHANNEL WIDTH IS INVALID OR IS NOT GIVEN

Correct the width data in the channel definition.

- 7) THERE IS A DIFFERENCE BETWEEN THE NO. OF PIERS AND THE NUMBER OF VALUES FOR PIER DEPTHS

If fewer depths are given for piers in an irregular section than the number of piers indicated, then the remaining pier base values must be added even if they are 0.0. If more depths are given only the amount up to the number of piers declared will be considered.

### 9.1.6 ERROR MESSAGES IN CROSS SECTION POINT PROCESSING

- 1) ENCOUNTERED A POINT WHERE  $X = 0$  AND  $Y = 0$  BEFORE ALL THE INDICATED POINTS WERE PROCESSED - ASSUMING ERROR

Only the first coordinate of the cross section points can be 0, 0 - otherwise the program cannot distinguish between blanks and zeroes. If point desired is 0, 0 use .01, .01 for approximate data. Correct invalid data.

- 2) THE CROSS SECTION POINTS ARE OUT OF SEQUENCE FOR AN IRREGULAR OPEN SECTION - MUST BE COUNTER - CLOCKWISE FROM MINIMUM X

Check the sequence of points on the cross section point cards for the data which is out of order.

- 3) THE CROSS SECTION POINTS ARE OUT OF SEQUENCE FOR AN IRREGULAR SECTION - MUST BE COUNTER - CLOCKWISE FROM MINIMUM X

Check the sequence of points on the cross section point cards for the data which is out of order. When maximum X is reached the following X values must continually decrease.

- 4) MAXIMUM Y IS NOT AT EITHER SIDE OF AN OPEN IRREGULAR CHANNEL ASSUMED BAD DATA AND PROCESSING IS STOPPED

For some reason maximum Y was not at the end of an open irregular channel. Check input data and correct if wrong, otherwise see programmer.

### 9.1.7 COMPUTATION ERROR AND WARNING MESSAGES

- 1) INVALID RECORD CODE IN XXX, IREC = X, ELEMENT = XXX;

The subroutine, record code, and element number are printed. An invalid record code was encountered, the record code value should be between 1 and 9. This code is set internally in the edit phase so it is a program problem - see programming staff. Processing is stopped.

- 2) WATER SURFACE ELEVATION GIVEN IS LESS THAN OR EQUALS INVERT ELEVATION IN XXX, W.S. ELEV = INV + DC;

The subroutine name is printed. This is a warning message that there was no water surface elevation inputted for either the headworks or outlet or that the water surface inputted is less than the invert elevation causing DC to be the controlling depth. Processing continues.

- 3) WENTDS, NO AREA OF OBSTRUCTION IN ELEMENT XXX, A1 = XXX, A2 = XXX;

The element number, area in the U/S end, and area in the D/S end (based on depth from the U/S end) are printed. The area in the U/S end must be greater than the area in the D/S end. Make sure this is supposed to be a wall entrance and that the channel sections are described properly. Processing is stopped.

- 4) W.S. ELEV. IS 10 FEET OR MORE ABOVE OPEN CHANNEL WALLS IN XXX, STATION = XXX, D = XXX, DH = XXX;

The subroutine, station, depth, and maximum open flow depth are written. Open flow depth reached the maximum limit in the program. Raise the heights of the channel walls at this point and resubmit. Processing is stopped.

- 5) OVER 50 RECORDS WRITTEN IN XXX ELEMENT = XXX STATION = XXX;

The subroutine, element, and station are printed. The maximum number of 50 intermediate points in a reach element have been processed. Divide this reach element into two or more reaches at the station printed and resubmit. Processing is stopped.

- 6) CANNOT SOLVE QUADRATIC FORMULA FOR START OF OPEN FLOW IN RCHUS, STATION = XXX;

The station at the D/S end of the reach is printed. The solution to solving the quadratic formula was negative for the length of reach in pressure flow. There is no solution for this problem (it should not occur), if it does this element must be hand calculated and the other elements can be run with the hand calculated control depths. Processing is stopped.

- 7) OTLTJP HAS ERRONEOUS PROCESSING CODES, U/S CODE = X,  
D/S CODE = X, D = XXX, DC = XXX;

The U/S and D/S processing codes, depth, and critical depth are written. There must be at least U/S processing in the outlet. This is an internal program error because the processing codes for the outlet are improperly set. See programmer. Processing is stopped.

- 8) A STATION ON THE U/S OR D/S FILE IS PAST THE END OF THE REACH IN RCHJP, STATION FROM FILE = XXX, REACH STATION = XXX;

The station from the U/S or D/S file and the station at the U/S or D/S end of the reach are printed. The station on the file is not between the U/S and D/S ends of the reach. This is an internal problem, a station computed in U/S or D/S processing is in error or the value for the number of U/S or D/S records written is in error. See programmer. Processing is stopped.

- 9) THE KNOWN DEPTH EQUALED THE NORMAL DEPTH IN BERNLI,  
DEPTH = XXX;

The known depth is printed. This is a warning message that normal depth has already been reached. The depth at the end of the reach is set equal to normal depth. Processing continues.

- 10) THE UPPER AND LOWER LIMIT VALUES CALCULATED IN BERNLI WERE THE SAME, LOWER LIMIT = XXX, UPPER LIMIT = XXX;

The values from Bernoulli's equation based on the lower and upper limit depths are printed. This is a warning message indicating that depth cannot be found by Bernoulli's equation and that the upper and lower limit depths are the same. The depth at the end of the reach is set equal to the current known depth. Processing continues.

- 11) THE VALUE TO SOLVE FOR DEPTH IN BERNLI IS NOT BETWEEN THE UPPER AND LOWER VALUE LIMITS, DESIRED VALUE = XXX, UPPER LIMIT VALUE = XXX, LOWER LIMIT VALUE = XXX, UPPER LIMIT DEPTH = XXX, LOWER LIMIT DEPTH = XXX;

The value needed to solve Bernoulli's equation, the upper and lower limit values from Bernoulli's equation, and the upper and lower limit depths are printed. This is a warning message indicating that depth to solve Bernoulli's equation cannot be found between the limits where it is expected. Depth at the end of the reach is set to the current known depth or to normal depth depending on whether the desired value to solve Bernoulli's equation is greater or less than the prescribed limits. Processing continues.

- 12) THE XX FILE DOES NOT HAVE DEPTH AT THE HYDRAULIC JUMP IN JUMPR;

The U/S or D/S file is printed. The station of the hydraulic jump cannot be computed although it is indicated to exist because the U/S and D/S force curves crossed. The actual location of the jump is not included on either the U/S or D/S file. This is an internal problem and should not happen. Check U/S and D/S reach processing to see if they are valid (print switch = 2). See programmer. Processing is stopped.

- 13) NO INTERSECTION OF FORCE CURVES COULD BE FOUND FOR THE HYDRAULIC JUMP IN JUMPR;

A hydraulic jump was indicated but there was insufficient data on the U/S and D/S files to locate the point of intersection. This is an internal problem and should not occur. Check U/S and D/S reach processing to see if they are valid (print switch = 2). See programmer. Processing is stopped.

- 14) THE FORCE AT THE HYDRAULIC JUMP IS NOT BETWEEN THE FORCES FROM THE UPPER AND LOWER LIMIT DEPTHS, UPPER LIMIT DEPTH = XXX, LOWER LIMIT DEPTH = XXX, UPPER LIMIT FORCE = XXX, LOWER LIMIT FORCE = XXX, FORCE AT JUMP = XXX IN PPMDEP;

The upper and lower limit depths (depth from either side of indicated hydraulic jump), the upper and lower limit forces, and the force at the hydraulic jump are written. The force at the jump should be equal or between the forces on either side of the jump but this was not the case. Either the force given for the jump or the points given from the U/S or D/S file adjacent to the jump are wrong. Check the U/S and D/S files for valid data (print switch = 2). This is an internal problem. See programmer. Processing is stopped.

- 15) THE TEST DEPTH EXCEEDED THE UPPER LIMIT DEPTH BEFORE THE FORCE AT THE JUMP WAS REACHED, TEST DEPTH = XXX, UPPER LIMIT DEPTH = XXX, TEST FORCE = XXX, JUMP FORCE = XXX IN PPMDEP;

The iterated depth, upper limit depth, iterated force, and force at the hydraulic jump are printed. The depth causing the force at the hydraulic jump should be equal or between the depths on either side of the jump but this was not the case. Either the force given for the jump or the points given from the U/S or D/S file adjacent to the jump are wrong. Check the U/S and D/S files for valid data (print switch = 2). This is an internal problem. See programmer. Processing is stopped.



- 16) ELEMENT NO. XXX HAS DNORM OR DCRIT LESS THAN OR EQUAL TO ZERO IN ELMCHG;

The element number is printed. Either normal depth or critical depth could not be computed for this reach. This should not happen, check the channel description for the reach element. Hand calculate normal and critical depths and if they exist in the channel description see a programmer because either function DNORM or function DCRIT is in error. This exists as a warning message and processing will continue but will probably terminate before the end of the run.

- 17) XXX ERRORS WERE ENCOUNTERED IN SETTING THE PRELIMINARY VALUES IN ELMCHG;

The number of errors in analyzing adjacent elements and flow rates and computing critical and normal depths is written. These errors must be corrected and the program must be rerun before actual processing will start. If this message occurs on the same run for other than the first flow rate there is an internal problem, then see the programmer. Processing is stopped.

- 18) NO XX RECORDS EXISTED WHERE INDICATED - ELEMENT NO. XXX IN WRITEN;

The U/S or D/S file and the element number are printed. The U/S or D/S processing code indicated the computation for the element was valid but there were no records on that file for the element. This is an internal problem with the processing codes. See programmer. Processing continues with the next element.

- 19) THERE WAS NO JUMP INDICATED WHEN BOTH U/S AND D/S RECORDS EXISTED FOR ELEMENT XXX IN WRITEN;

The element number is printed. There was a problem in the jump processing for this element. Either one of the profiles should be deleted or a hydraulic jump should be indicated. This is an internal problem, see programmer. Processing continues with the next element.

- 20) A JUMP WAS INDICATED BUT THERE WERE NOT RECORDS ON BOTH THE U/S AND D/S PROFILES FOR ELEMENT XXX IN WRITEN;

The element number is printed. There was a problem in the jump processing for this element. If the entire U/S or D/S profile is deleted then there cannot be a jump and if there is a jump there must be U/S and D/S profile data. This is an internal problem, see programmer. Processing continues with the next element.

- 21) THERE WERE NO RECORDS FOR ELEMENT XXX IN WRITEN;

The element number is printed. This is a warning message to indicate there was no U/S or D/S processing for this element. Check the U/S and D/S profiles (print switch = 2) to verify this. If there is data there is an internal problem, if there is no data check the construction of the element. Processing continues with the next element.

- 22) NO PLOT GENERATED, BAD DATA OR NOT ENOUGH POINTS, 3 OR LESS;

If there are only 3 elements being run no plot will be generated, otherwise there was a problem in processing one of the elements and there is an internal problem. This is a warning message and processing continues.

- 23) ELEMENT NUMBER XXX HAS ADJACENT ELEMENTS WHICH ARE IN ERROR;

The element number is printed. There is an error in the sequence of elements submitted (such as bridge exits back to back) which are not allowed. Check the sequence of the elements, correct the error, and resubmit the data. This is a user error, sequence checking will continue but actual processing will be stopped.

- 24) XXX DEPTH COULD NOT BE FOUND IN ELEMENT XXX;

Either normal or critical depth and element number are printed. There is either an error in function DCRIT or DNORM or there is a bad channel description. Hand calculate the value and if it is valid for the channel see a programmer. The elements will continue to be checked but no actual processing will take place until the error is resolved.

- 25) IRREGULAR XXX VALUES ARE ZERO OR NEGATIVE, SET XXX EQUAL TO ZERO, XXX = XXX, PIER XXX = XXX, IN XXX;

Either force, area, or wetted perimeter values are printed from functions FORCEI, AREACI, or WETPI for irregular sections. The appropriate data could not be computed in this irregular section. The problem is internal. The cross section points used for the computation are probably distorted. See a programmer. The desired value is set to zero and processing continues but will probably be in error and processing will probably terminate before the end of the run.

- 26) PIER WIDTH IS WIDER THAN CHANNEL WIDTH IN XXX, DEPTH = XXX, PIER WIDTH = XXX;

Either force, area, or wetted perimeter, depth, and average pier width is printed. The width of the number of piers at the given depth is wider than the channel width at that depth. This is a user error. Correct the input data and resubmit. The desired value is set to zero and processing continues but results will probably be erroneous and the program will probably terminate before the end of the run.

- 27) DEPTH EXCEEDS XXX WITH FORCE TOO LOW IN FORCEM, TEST DEPTH = XXX, TEST FORCE = XXX, XXX = XXX, DESIRED FORCE = XXX;

The iterated depth and force, the maximum or minimum depth, and the desired force value are printed. The desired force in the bridge exit could not be reached within the prescribed depth limits. The desired depth is set to zero and no processing is done in that end of the bridge exit. Processing continues with the next element.

- 28) DESIRED FORCE IS OUT THE RANGE OF DEPTHS IN FORCEF, TEST DEPTH = XXX, TEST FORCE = XXX, XXX = XXX, DESIRED FORCE = XXX;

The iterated depth and force, the maximum or minimum depth, and the desired force are printed. In D/S processing the desired force in the D/S end of the bridge entrance could not be reached within the prescribed limits of depth so the desired depth is set to zero and no computation is done in the D/S end. In U/S processing the bridge entrance was under pressure at the U/S end so pressure flow calculations will be done. Processing is continued for pressure flow going U/S and in the next element going D/S.

- 29) DESIRED FORCE IS OUT OF THE RANGE OF DEPTHS IN FWALL, TEST DEPTH = XXX, TEST FORCE = XXX, MINIMUM DEPTH = XXX, DESIRED FORCE = XXX;

See Message 28 for D/S bridge entrance only use wall entrance instead.

- 30) DEPTH IS OUTSIDE THE RANGE OF THE POINTS DESCRIBING THE CHANNEL IN XXX, DEPTH = XXX, YMIN = XXX, YMAX = XXX;

Either force, area, or wetted perimeter values for depth and minimum and maximum Y values are printed. If the depth is not above maximum open flow depth there is an internal error, see programmer. If the depth exceeds maximum open flow depth raise the channel walls. The desired value is set to zero and processing continues but will probably be in error and processing will probably terminate before the end of the run.

- 31) UNABLE TO CALCULATE FRICTION SLOPE WITH MANNINGS EQUATION IN SF, AREA = XXX, WETTED PERIMETER = XXX;

The area and wetted perimeter are printed. Either the area or wetted perimeter should be less than or equal to zero. This is an internal problem, see programmer. Processing is stopped.

- 32) CRITICAL DEPTH MAY BE INACCURATE IN ELEMENT XXX, INCREMENT = XX;

The element number and increment value are printed. If the increment is large then critical depth is probably above the top of the channel but is set equal to the channel height. If the increment is small critical depth is probably pretty accurate but for some reason it cannot be computed precisely. This is a warning and processing continues.

- 33) Q VALUES IN THE JUNCTION ARE INCORRECT FOR DEPSMP, Q1 = XXX, Q2 = XXX, Q3 = XXX, Q4 = XXX;

The Q values for both U/S and D/S ends and for the laterals are printed. Q2 should equal the sum of the other Q's. If it does not there is an internal error in subroutine ELMCHG, see a programmer. If these Q values are in error, resubmit the input data with the correct Q values. Processing is stopped.

- 34) A LATERAL ANGLE OF CONFLUENCE IS GREATER THAN 90 DEGREES IN DEPSMP, FIRST ANGLE OF CONFLUENCE = XXX, SECOND ANGLE OF CONFLUENCE = XXX;

The angles of the laterals are printed. This is a user error, check the values inputted for the angles of the laterals, they should be in degrees. Processing is stopped.

- 35) INVALID PROCESSING CODE WAS ENCOUNTERED IN XXX, PROCESSING CODE = X, AND IT SHOULD BE 1 OR 2;

Function DEPSMP, SUMM, or SUMP is printed with the processing code. The processing code should be 1 for D/S processing and 2 for U/S processing representing the known end of the element. This code is internally set just before the function is called so it is a programming problem. Processing is stopped.

- 36) MOMENTUM AND PRESSURE CURVES DID NOT CROSS IN DEPSMP, SETTING DEPTH EQUAL TO UPPER LIMIT DEPTH PLUS ONE FOOT, DEPTH = XXX;

The depth is printed. The intersection of the pressure and momentum curves was above the maximum open flow depth. For a closed channel pressure flow calculations will be executed, otherwise, processing will stop because depth is too high in an open channel. This is a warning message.

#### 9.1.8 DEBUG MESSAGE

NO COMPUTATION IN XXXX - A BREAK IN WATER SURFACE PROFILE,  
STATION = XXX, XXXX

The station, subroutine, and paragraph number are printed. This is a notification message which identifies whether there was any computation for the U/S or D/S end of an element.

Other messages printed in debug trace have the subroutine or function and paragraph number printed.

## 10.1 SYSTEM RECOVERY PROCEDURE

If any job fails to process to a normal end for any reason, please contact the Data Processing Section and bring all pertinent information with you to aid in solving the problem.

## 11.1 PROGRAM LIMITATIONS

- 1) A maximum of 200 elements are allowed per run.
- 2) A maximum of 50 intermediate points can be computed in a reach element.
- 3) Critical depth cannot exceed 100 feet.
- 4) Program will not compute the water surface profile when the friction slope is at one or greater.
- 5) Open channel processing is limited to a depth ten feet above the height of the described element.
- 6) Undulating bottoms cannot be calculated properly in an irregular shaped section unless the depth of flow is above the undulations.
- 7) The program will not accept vertical drops in invert elevations.
- 8) Calculations in the Water Surface profile print out may be slightly inaccurate (to .001) due to rounding variables to be contained on the U/S and D/S data files.
- 9) The invert cross fall "e" in inches is optional and may be used only with channel type two, a rectangular open channel or R.C. Box Sections.

## 12. APPENDIX

This Appendix contains the computational symbols, methods, procedures, and equations used in the program.

Table of Contents		Page
12.1	Symbol Definitions-----	91
12.2	Irregular Section Definitions-----	93
12.3	Conduit Section Geometry Equations-----	94
12.3.1	Flow Area-----	95
12.3.2	Wetted Perimeter-----	96
12.3.3	Hydrostatic Pressure-----	97
12.3.4	Depth of Flow-----	98
12.4	Computational Procedures-----	99
12.4.1	Basic Equations of Steady Flow-----	99
12.4.2	Reach Analysis-----	101
12.4.3	Transition Analysis-----	102
12.4.4	Junction Analysis-----	102
12.4.5	Pier Analysis-----	103
12.4.6	Wall Entrance Analysis-----	104
12.4.7	Wall Exit-----	104
12.5	Pictorial of Input Deck-----	105
12.6	References-----	106



## 12.1 SYMBOL DEFINITIONS

<u>Symbol</u>	<u>Definition</u>
A	Cross sectional area of flow
Ap	Cross sectional area of pier
b	Base width of channel
bnet	Net base width of channel
bp	Average base width of piers
D	Depth of flow
Dc	Critical depth
L	Length between two stations
H	Drop in invert between two points
DH	Maximum open flow depth in a section: Ten feet above channel height in open section, Height of channel in closed section
DN	Normal depth
E	Specific Energy
EGL	Energy Grade Line elevation
e	Invert cross fall in inches may be used with channel type two only (optional)
F	Force
g	Gravitational constant (32.2 ft/sec/sec/)
HAPT	Head loss due to angle point
HB	Head loss due to bend or curve
HF	Head loss due to friction
HJ	Head loss in a junction
HMH	Head loss in a manhole
Ht	Head loss in a transition
HV	Velocity head
INV	Invert elevation in a channel section
M	Momentum
n	Manning's n, coefficient of roughness
No P	Number of piers in a section (max. of 10)
P	Hydrostatic Pressure
Q	Flow rate
R	Radius of pipe
RH	Hydraulic radius
r	Radius of curve on horizontal alignment
SF	Friction slope (energy loss per foot)
Sc	Critical slope (slope at critical depth)
So	Invert slope
SE	Super elevation
STA	Station
V	Velocity
WP	Wetted perimeter
WS/HGL	Water Surface or Hydraulic Grade Line Elevation
ZL	Left side slope
ZR	Right side slope

These variables may have one of two suffixes

- 1: Identifies the variable at the upstream end of an element.
- 2: Identifies the variable at the downstream end of an element.

Example: V1: is velocity at the upstream end  
          V2: is velocity at the downstream end.

Throughout this program: U/S is the upstream end  
                              D/S is the downstream end

## 12.2 IRREGULAR SECTION DEFINITIONS

Points  $i(X, Y)$  from  $i = 1$  to  $i = n$ , in counter clockwise direction ( $3 \leq n \leq 99$ ) define an irregular cross section.

$X(i)$  : X coordinate of point(i)

$Y(i)$  : Y coordinate of point(i)

$Y(p)$  : Y coordinate of base of pier, from  $P = 1$  to  $P = n$  given from left to right ( $0 \leq n \leq 10$ )

$\Delta X(i) = X(i) - X(i-1)$

$\Delta Y(i) = Y(i) - Y(i-1)$

$Y_{min} =$  The least  $Y(i)$

$Y(i) = Y(i) - Y_{min}$ , subtract  $Y_{min}$  from every  $Y(i)$  on file

$Y(P) = Y(P) - Y_{min}$ , subtract  $Y_{min}$  from every  $Y(P)$  on file

$Y_{max}$  : Maximum open flow depth in a cross section  
All points whose  $Y(i) > Y_{max}$  will be dropped from file

$Y(D)$  : Depth of flow in a section part full or under pressure

$DH = Y_{max} + 10'$  in an open top section

$DH = Y_{max}$  in a covered section

Point  $iBEG(X, Y)$ : Contact Point of W.S. and the left bank.

If  $[Y(D) \geq Y_{max}]$  then  $Y(iBEG) = Y_{max}$

and  $X(iBEG)$  is least  $X$  for  $Y_{max}$

If  $[Y(D) < Y_{max}]$  then  $Y(iBEG) = Y(D)$

$X(iBEG) = [ \Delta X(i+1) / \Delta Y(i+1) ] [Y(D) - Y(i)] + X(i)$

where  $Y(i)$  and  $Y(i+1)$  are the domain of  $Y(D)$  from  $Y(1)$  to  $Y_{min}$ .

Point iEND (X, Y): Contact Point of W.S. and the right bank.

If  $[Y(D) \geq Y_{max}]$  then  $Y(iEND) = Y_{max}$

and  $X(iEND)$  is the maximum  $X$  with  $Y_{max}$ .

If  $[Y(D) < Y_{max}]$  then  $Y(iEND) = Y(D)$

$$X(iEND) = [\Delta X(i+1) / \Delta Y(i+1)] [Y(D) - Y(i)] + X(i)$$

where  $Y(i-1)$  and  $Y(i)$  are the domain of  $Y(D)$  from  $Y_{min}$  to  $Y(n)$ .

Let Point 1 (X, Y) = Point iBEG (X, Y)

where  $X(1) = X(iBEG)$   
 $Y(1) = Y(iBEG)$

Let Point n (X, Y) = Point iEND (X, Y)

where  $X(n) = X(iEND)$   
 $Y(n) = Y(iEND)$

Also Point n+1 (X, Y) = Point 1 (X, Y)

where  $X(n+1) = X(1)$   
 $Y(n+1) = Y(1)$

### 12.3.1 AREA (A)

The Area (A) of flow is a function of the depth of flow and the geometry of the channel or conduit section.

1. CHAN. TYPE 1:

$$A = D [b_{net} + 0.5 D (Z_L + Z_R)]$$

2. CHAN. TYPE 2:

$$A = [D \cdot b_{net}] - [e \cdot b_{net}/24]$$

3. CHAN. TYPE 3:

If D is less than Chan. height (H) see Process 1. Otherwise:

$$A = H [b_{net} + 0.5 H (Z_L + Z_R)] - [0.25 (1 + NOP)]$$

4. CHAN. TYPE 4:

If D is equal or greater than Diameter

$$A = \pi (R)^2$$

otherwise

$$A = (D-R) \sqrt{2RD - (D)^2} + [\pi (R)^2 / 180] [\text{Arcsin} ((D-R)/R)] + \pi (R)^2 / 2$$

5. CHAN. TYPE 5:

$$A = \sum_{i=2}^{i=n+1} \Delta X(i) [Y(D) - Y(i)] + 0.5 [\Delta X(i) - \Delta Y(i)] - \sum_{P=1}^{P=n} (bp) [Y(D) - Y(P)]$$

6. CHAN. TYPE 6:

See Process 5.

### 12.3.2 WETTED PERIMETER (WP)

WP is a function of the depth of flow and the geometry of the conduit or channel section.

1. CHAN. TYPE 1:

$$WP = D \left[ \sqrt{1 + (ZL)^2} + \sqrt{1 + (ZR)^2} + (2 \cdot NOP) \right] + b_{net}$$

2. CHAN. TYPE 2:

$$WP = 2 D (1 + NOP) + b_{net}$$

3. CHAN. TYPE 3:

If D is less than chan. height (H) see Process 1. Otherwise

$$WP = D \left[ \sqrt{1 + (ZL)^2} + \sqrt{1 + (ZR)^2} + (2 \cdot NOP) \right] + [2b_{net}] + [H (ZL + ZR)]$$

4. CHAN. TYPE 4:

If D is equal or greater than pipe diameter (2R) then

$$WP = 2 \pi R$$

Otherwise

$$WP = [\pi R / 90] [\text{ARCCOS} ((R-D)/R)]$$

5. CHAN. TYPE 5:

$$WP = \sum_{i=2}^{i=n} \sqrt{[\Delta X(i)]^2 + [\Delta Y(i)]^2} + \sum_{P=1}^{P=n} 2 [Y(D) - Y(P)] - b_p$$

6. CHAN. TYPE 6:

If D is less than Ymax see Process 5. Otherwise

$$WP = \sum_{i=2}^{i=n+1} \sqrt{[\Delta X(i)]^2 + [\Delta Y(i)]^2} + \sum_{P=1}^{P=n} 2 [Y(D) - Y(P)] - b_p$$

### 12.3.3 HYDROSTATIC PRESSURE (P)

Pressure is a function of the depth of flow and the geometry of the conduit or channel section.

1. CHAN. TYPE 1:

$$P = 0.5 (D)^2 [b_{net} + D (ZL + ZR)/3], \quad \text{where } b_{net} = b - (NOP \cdot bp)$$

2. CHAN. TYPE 2:

$$P = 0.5 [b_{net} (D)^2]$$

3. CHAN. TYPE 3:

If D is not greater than chan. height (H) see Process 1. Otherwise:

$$P = 0.5 (D)^2 [b_{net} + D (ZL + ZR)/3] - 0.5 (D-H)^2 [(1/3)(ZL + ZR)(2H + D) + b_{net}]$$

4. CHAN. TYPE 4:

If D is equal or greater than the pipe diameter then

$$P = (D-R) \pi (R)^2$$

Otherwise:  $C = (D/R)$  and:

$$P = (R^3 / 3) \left\{ [(C)^2 - (2C) + 3] \sqrt{2C - (C)^2} + \left[ \frac{\pi}{60} (C-1) \right] [90 + \text{ARCSIN} (C-1)] \right\}$$

5. CHAN. TYPE 5:

$$P = 0.5 \sum_{i=2}^{i=n+1} \Delta X(i) [D - Y(i)]^2 + \Delta X(i) \Delta Y(i) [D - Y(i) + \Delta Y(i)/3] - \sum_{P=1}^{P=n} 0.5 bp [D - Y(P)]^2$$

6. CHAN. TYPE 6:

If D is not greater than Ymax see Process 5. Otherwise:

$$P = \sum_{i=2}^{i=n+1} 0.5 \Delta X(i) [D - Y(i)]^2 + 0.5 \Delta X(i) \Delta Y(i) [D - Y(i) + \Delta Y(i)/3] - \sum_{P=1}^{P=n} bp [Y_{max} - Y(P)] [D - 0.5 Y_{max} - 0.5 Y(P)]$$

#### 12.3.4 DEPTH OF FLOW (D)

Depth computation when area of flow is known.

1. CHAN. TYPE 1:

$$D = \frac{1}{Z + Z} \left\{ -b_{net} + \sqrt{(b_{net})^2 + 2(ZL + ZR) [A]} \right\}$$

2. CHAN. TYPE 2:

$$D = (1/b_{net}) [A] + (e.b_{net}/24)$$

3. CHAN. TYPE 3:

Compute AH (The Full Area of a closed section).

If A is less than AH see Process 1. Otherwise:

$$D = HGL - Inv.$$

4. CHAN. TYPE 4:

Compute AH.

If A is not less than AH

$$D = HGL - Inv.$$

Otherwise

Find D by trial and error from Area of part full pipe.

5. CHAN. TYPE 5:

Find D by trial and error from Area of part full section.

6. CHAN. TYPE 6:

Compute AH

If A is not less than AH then

$$D = HGL - Inv$$

Otherwise

Find D by iteration from Area of part full irregular section.



## 12.4 COMPUTATIONAL PROCEDURES

Assumptions are: Steady one dimensional flow and incompressible fluids.

### 12.4.1 BASIC EQUATIONS OF STEADY FLOW

a) Equation of Continuity

$$A_1.V_1 = A_2.V_2 = Q$$

b) Manning's Formula (friction slope)

$$S_f = \left\{ \frac{Q n}{1.486 A (RH)^{\frac{2}{3}}} \right\}^2$$

c) Bernoulli's Equation (open flow)

$$D_2 + HV_2 + \Delta L S_{f_{av}} = D_1 + HV_1 + \Delta L S_o \quad \text{where } HV = \frac{V^2}{2g}$$

d) Bernoulli's Equation (pressure flow)

$$D_2 + HV_2 + \Delta L S_{f_{av}} + H_m = D_1 + HV_1 + \Delta L S_o$$

where  $H_m$  is miscel. losses.

e) Angle Point Loss

$$H_{ap} = 0.0033 \ominus HV$$

Where  $\ominus$  is deflection angle in degrees. The District recommends not to exceed  $6^\circ$ .

f) Bend Loss

$$H_B = 0.2 HV \sqrt{\Delta / 90}$$

where  $\Delta$  is central angle of bend in degrees.

g) Manhole Loss

$H_{mh} = 0.05 HV$  (No. MN) where No. MH is number of manholes in a reach

h) Specific Energy

$$E = D + HV$$

i) Pressure - Momentum

$$P_2 + M_2 = P_1 + M_1 = F$$

$$\text{where } M = (Q)^2 / (Ag)$$

j) Critical Depth  $D_c$

$D_c$  is the depth of flow at minimum energy; to find  $D_c$  by parabolic method see References 12.6.4 otherwise iterate for  $D_c$  in the specific energy equat.

$$E_c = f(D_c) = D_c + HVC$$

k) Normal Depth  $D_n$

$D_n$  is the depth of uniform flow and is found by iteration from Manning's formula

$$A(RH)^{2/3} = f(D_n) = [Q n] / [1.486 S_o^{1/2}]$$

## 12.4.2 REACH ANALYSIS

### a) Open Flow

Intermediate points are computed on the W.S. profile in a reach using the standard step method. The difference in velocity head between two adjacent points is held to a maximum of ten per cent.

$$\Delta L = (E2 - E1) / (So - Sf_{av})$$

### b) Pressure Flow

$$EGL\ 1 = EGL\ 2 + H_f + H_m$$

$$D1 = EGL\ 1 - HV1 - INV.\ 1$$

If W.S. profile rises to the soffit of a conduit before the end of the reach or if the H.G.L. breaks seal before the end of the reach, minor losses are adjusted to reflect only the portion of the reach under pressure.

### Super Elevation (S.E.)

Super elevation is computed in curving channels as follows:

#### CHAN. TYPE 1: (Trap. Sect.)

$$\text{Subcritical flow: } S.E. = 1.15 [HV/r] [b + D (ZL + ZR)]$$

$$\text{Supercritical flow: } S.E. = 2.6 [HV/r] [b + D (ZL + ZR)]$$

#### CHAN. TYPE 2: (Rect. Sect.)

$$\text{Subcritical flow: } S.E. = HV\ b/r$$

$$\text{Supercritical flow: } S.E. = 2\ HV\ b/r$$

### 12.4.3 TRANSITION ANALYSIS

If  $V_2$  is greater than  $V_1$  then

$$H_t = 0.1 [HV_2 - HV_1]$$

otherwise

$$H_t = 0.2 [HV_1 - HV_2]$$

### 12.4.4 JUNCTION ANALYSIS

$$\Delta Y = [(Q_2 \cdot V_2) - (Q_1 \cdot V_1) - (Q_3 \cdot V_3 \cdot \cos \theta_3) (1/g) (1/A_{ave})] + \Delta L S_f av$$

$$\text{where } A_{ave} = [(A_1 + A_2)/2]$$

$$\text{and } \Delta Y = D_1 + \Delta H - D_2$$

$$H_J = \Delta Y + HV_1 - HV_2$$

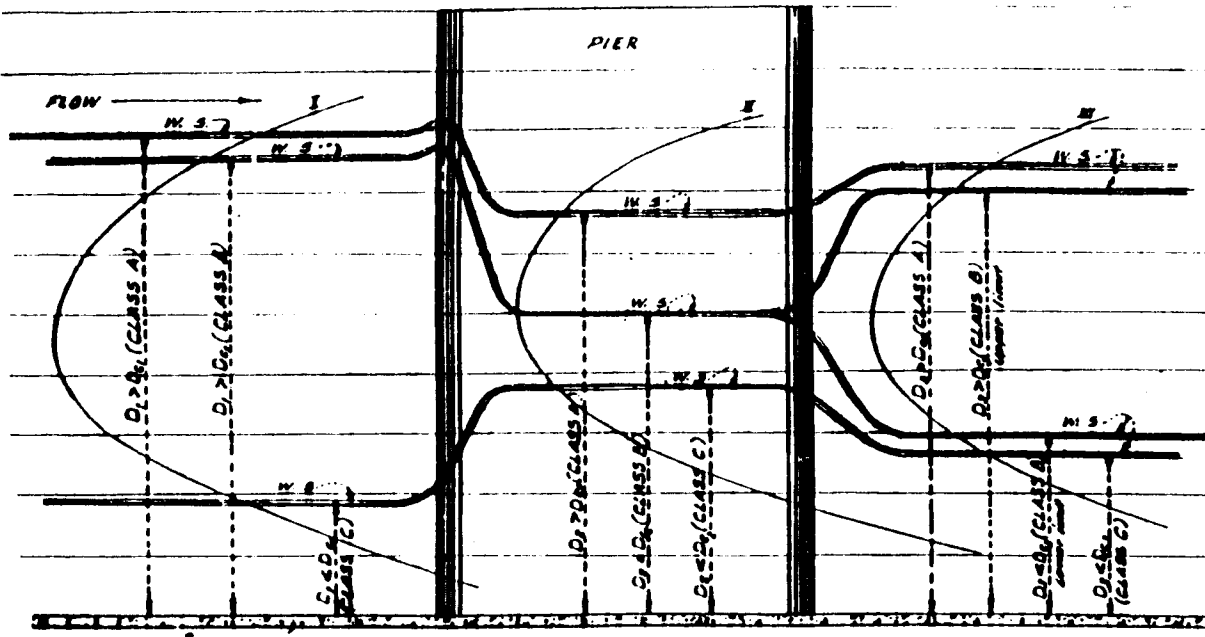

LONGITUDINAL PROFILE

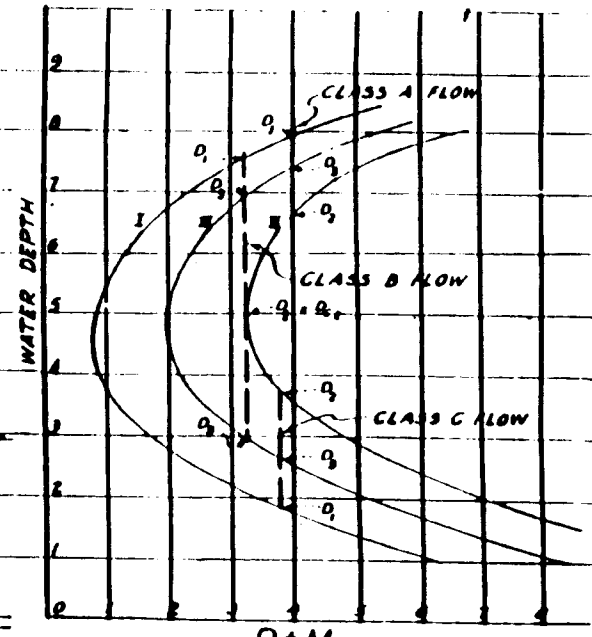

PRESSURE+MOMENTUM CURVES

GENERAL MOMENTUM EQUATION:

$$P_1 - P_2 + \frac{Q^2}{gA_1^2} (A_1 - A_2) = P_1 - P_2 + \frac{Q^2}{g(A_1 - A_2)^2} (P_2 - P_1) + \frac{Q^2}{gA_2^2}$$

NOTATIONS:

- I, II, III = P-M curves upstream inside and downstream of bridge respectively
- $D_1, D_2, D_3$  = Water depths upstream, inside and downstream of bridge respectively
- $D_{c1}, D_{c2}$  = Critical depth within bridge
- $W$  = Channel width
- $P_1 = P_2$  = Hydrostatic pressure in unobstructed channel.
- $P_3$  = Hydrostatic pressure of bridge piers.
- $A_1, A_2$  = Area of unobstructed channel in sq ft
- $A_p$  = Area of bridge piers in sq ft
- $Q$  = Discharge in cfs
- $g$  = Gravitational constant
- $D_{c1}, D_{c2}$  = Critical in unobstructed channel
- = Use  $\frac{1}{2} A_p$  for round nose piers

Los Angeles County Flood Control District

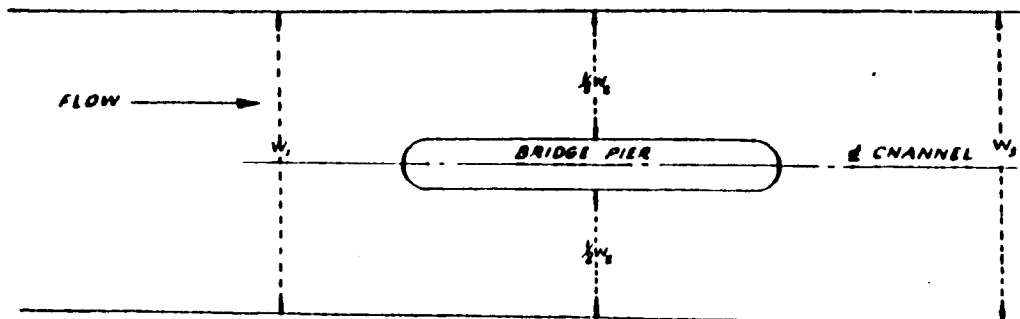

PLAN

**BRIDGE PIER LOSSES BY THE MOMENTUM METHOD**

#### 12.4.6 WALL ENTRANCE ANALYSIS (Sudden Contraction)

##### Lower Stage Profile (U/S Control)

Find depth at the D/S end by iteration in the equation.

$$M_2 + P_2 = M_1 [(A_1 - A_{1WALL}) / A_1] + P_1 - P_{1 \text{ walls}}$$

where  $A_1$  wall is the area of the obstructed part of  $A_1$ . And  $P_1$  wall is the pressure on the obstructed part of  $A_1$

##### Upper Stage Profile (D/S Control)

If the control depth is less than the conduit height find the depth at the U/S end from

$$M_2 + P_2 = M_1 [(A_1 - A_{1WALL}) / A_1] + P_1 - P_{1 \text{ wall}}$$

otherwise find  $D_1$  by iteration from the following equation:

$$D_2 + HV_2 + K_c \text{ ABS } [HV_2 - HV_1] = D_1 + HV_1$$

where  $K_c \text{ ABS } [HV_2 - HV_1]$  is the head loss at WE.

$$K_c = 0.5 \text{ unless given otherwise}$$

ABS = the absolute value

#### 12.4.7 WALL EXIT (Sudden Expansion)

$$\text{Energy loss in a wall exit} = 1.0 \text{ ABS } [HV_2 - HV_1]$$

In WX find  $D_1$  or  $D_2$  by iteration in the following

$$D_2 + HV_2 + 1.0 \text{ ABS } [HV_2 - HV_1] = D_1 + HV_1$$

12.5 PICTORIAL OF INPUT DECK

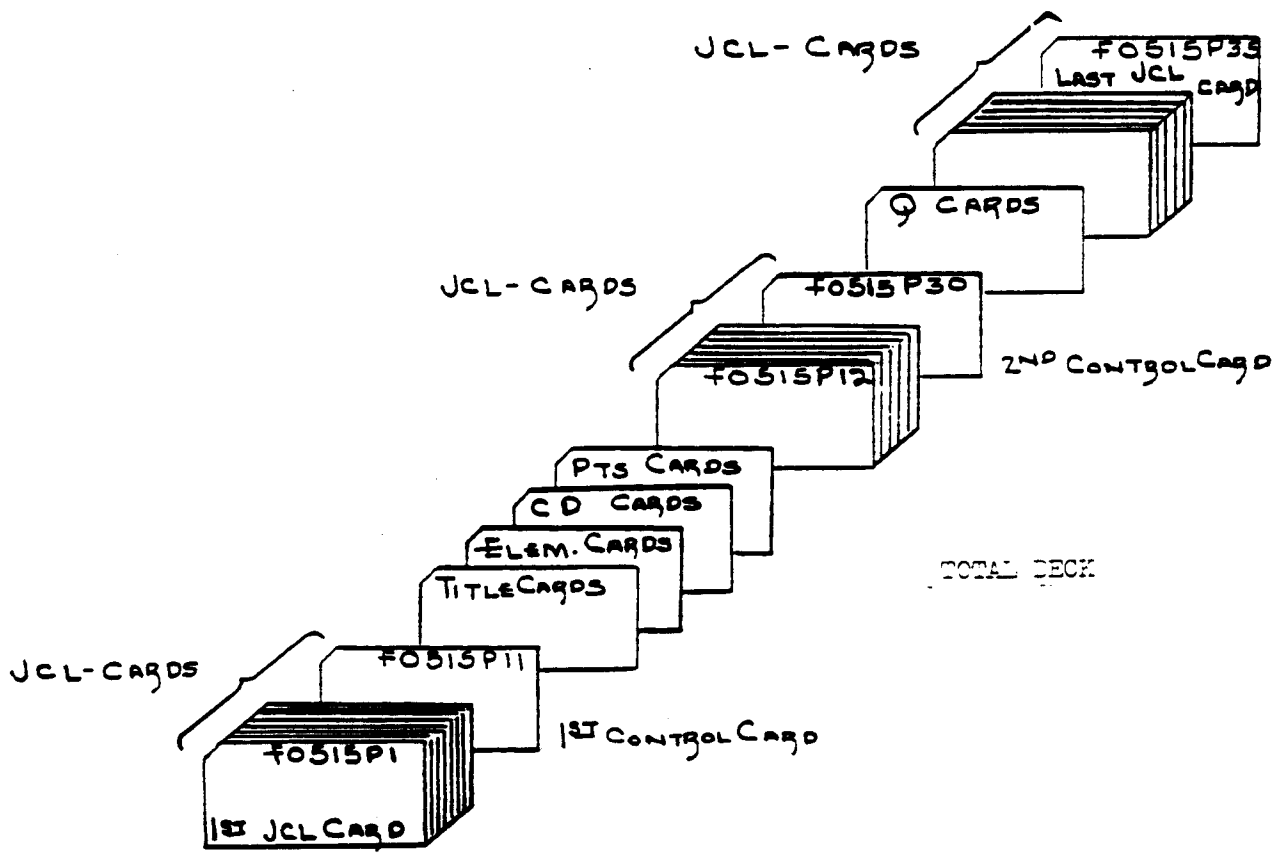
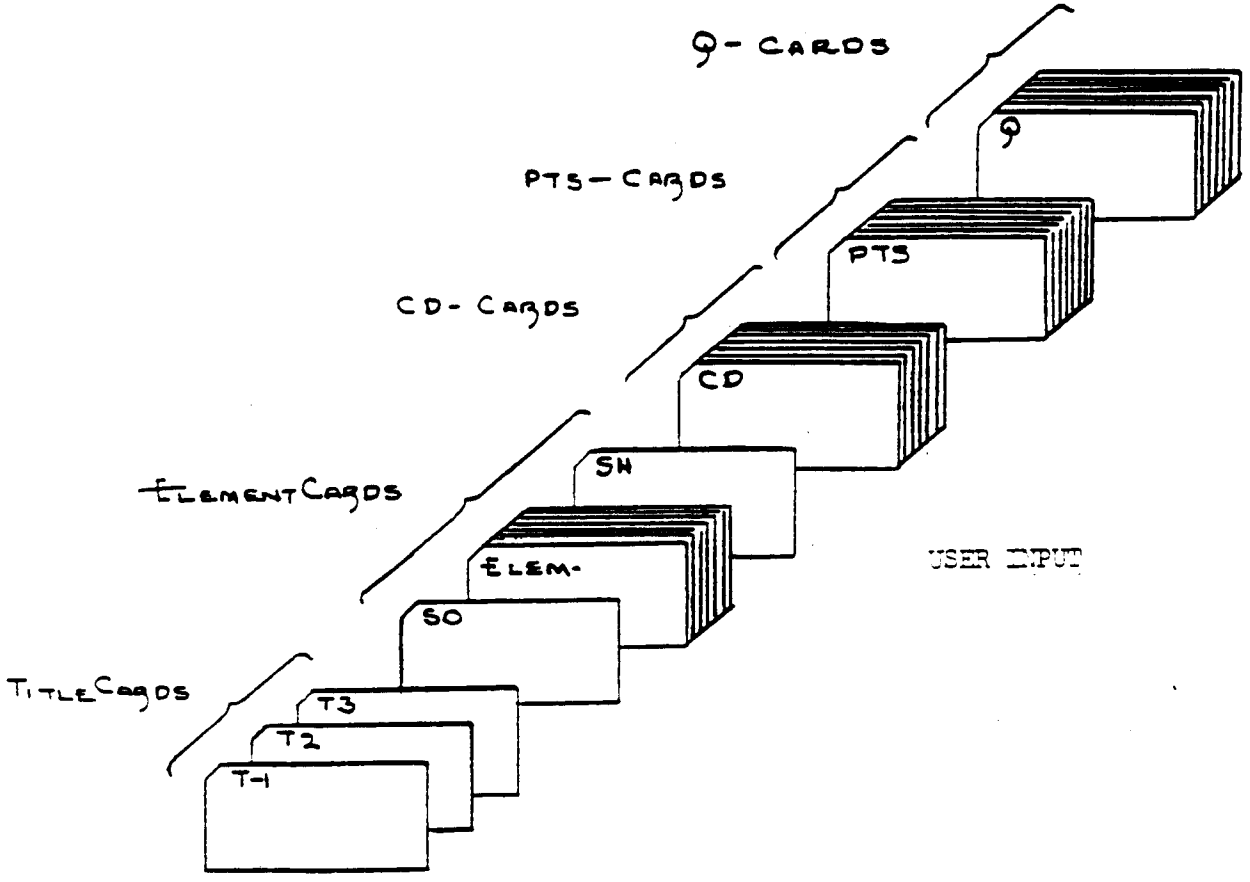

## 12.6 REFERENCES

1. Hydraulic Design Manual, L.A.C.F.C.D. (1970)
2. Handbook of Hydraulics, E. F. Brater and H. W. King
3. Hydraulic Analysis of Junctions, City of L.A. Office  
Std. No. 115 (1968)
4. Critical Water Surface by Minimum Specific Energy Using the  
Parabolic Method, Hydrologic Engineering Center, U.S. Army Corps  
of Engineers, Eichert, Bill S.