

SHEET NO. 3-B OF 10 SHEETS
COMPL. SURVEYORS MAP NO. B-1184

SHEET NO. 3-B OF 10 SHEETS
COMPL. SURVEYORS MAP NO. B-1184

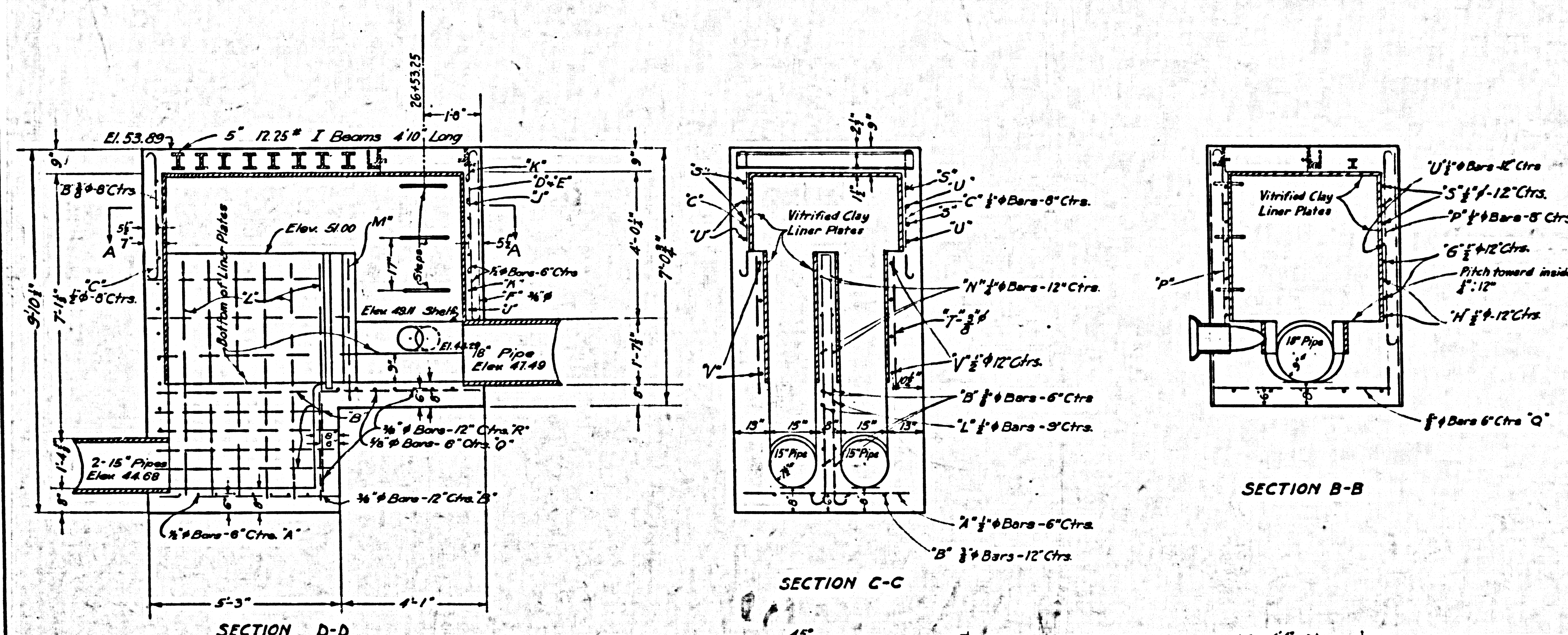

REINFORCING SCHEDULE					
Number	Type	Total Length	Size	Description	Location
B	A	5'-0"	1" φ	Straight	Trans. Bottom
25	B	5'-0"	1" φ	"	Div. Wall, Ends Bottom
19	C	4'-2"	1" φ	Hooked both ends	Subsidiary Vert.
3	D	5'-5"	1" φ	"	One end Vert.
4	E	7'-0"	1" φ	"	"
6	F	6'-9"	1" φ	Straight	Sides & One end Vert.
4	G	5'-0"	1" φ	Hooked both ends	"
4	H	6'-5"	1" φ	See detail	"
4	J	6'-0"	1" φ	Hooked both ends	One end Hor.
4	K	9'-0"	1" φ	See detail	"
6	L	4'-6"	1" φ	"	Div. wall Vert.
1	M	4'-0"	1" φ	Straight	"
3	N	11'-1"	1" φ	See detail	"
10	P	6'-2"	1" φ	Hooked both ends	Sides Vert.
7	Q	5'-0"	1" φ	Straight	Trans. Bottom
5	R	7'-6"	1" φ	See detail	Long Bottom End
8	R	4'-10"	5"	I-Beams	Top
1	S	2'-0"	3"	I-Beam	"
1	T	4'-10"	6"x6"	Angle Iron	"
1	T	2'-10"	4"x4"	"	"
4	T	7'-1"	4"x4"	"	"
4	T	0'-10"	3"x3"	Plates	Fillers
1	T	2'-0"	3"x3"	"	"
4	S	10'-2"	1" φ	Hooked both ends	Sides-Hor.
6	T	2'-0"	1" φ	Straight	Vert.
4	U	11'-6"	1" φ	See detail	"
8	V	10'-2"	1" φ	Hooked both ends	"

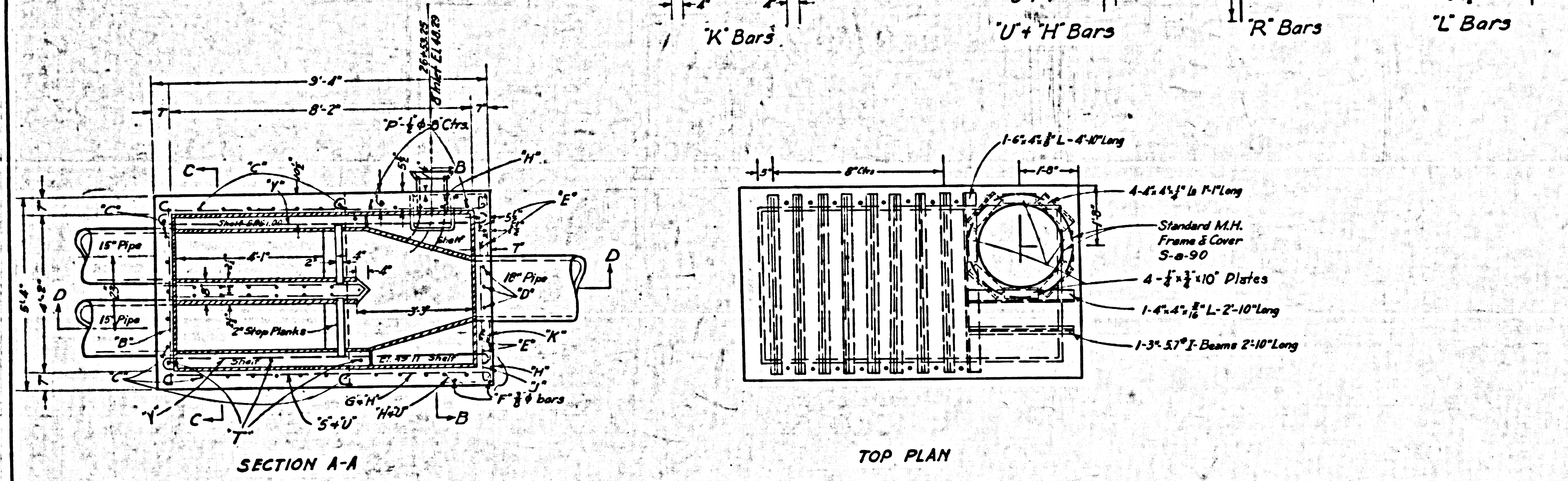
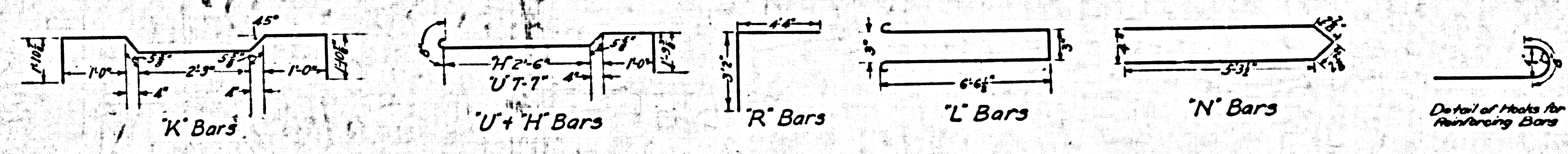

- NOTE:
1. CONCRETE STRENGTH AT 28 DAYS TO BE NOT LESS THAN 2500 # SQ. IN.
 2. ALL VITRIFIED CLAY LINER PLATE JOINTS TO BE MADE WITH C.P.I. # 201 JOINT COMPOUND.
 3. ALL STEEL INTERMEDIATE GRADE A.S.T.M. SPECIFICATIONS.

LENNOX
D. D. I. NO. 20 & D. D. I. NO. 24
DRAINAGE SYSTEM
OF THE COUNTY OF LOS ANGELES, CALIFORNIA
MANCHESTER AVE. PUMP TRUNK, COUNTY SANITATION DISTRICT NO. 5
SIPHON INLET
AT STORM DRAIN STATION 24 + 53.97
CYPRESS AVE. & P.E. # W
SHEET 3-B OF 10 SHEETS
SCALE 1/4" = 1'-00"
NOV. 1935
ALFRED JONES COUNTY SURVEYOR
RECOMMENDED *Alfred Jones* APPROVED *Alfred Jones*
APPROVED *Alfred Jones*

CSB-1164-9-B
A1 OF A1

J.N. 6865

SHEET NO. 3-B OF 10 SHEETS
COMPL. SURVEYORS MAP NO. B-1184

SHEET NO. 3-B OF 10 SHEETS
COMPL. SURVEYORS MAP NO. B-1184